

HOW TO USE THIS MANUAL

IN04A-01

GENERAL INFORMATION

1. INDEX

An INDEX is provided on the first page of each section to guide you to the item to be repaired. To assist you in finding your way through the manual, the Section Title and major heading are given at the top of every page.

2. GENERAL DESCRIPTION

At the beginning of each section, a General Description is given that pertains to all repair operations contained in that section.

Read these precautions before starting any repair task.

3. TROUBLESHOOTING

TROUBLESHOOTING tables are included for each system to help you diagnose the problem and find the cause. The fundamentals of how to proceed with troubleshooting are described on page IN-17 . Be sure to read this before performing troubleshooting.

4. PREPARATION

Preparation lists the SST (Special Service Tools), recommended tools, equipment, lubricant and SSM (Special Service Materials) which should be prepared before beginning the operation and explains the purpose of each one.

5. REPAIR PROCEDURES

Most repair operations begin with an overview illustration. It identifies the components and shows how the parts fit together.

Example:

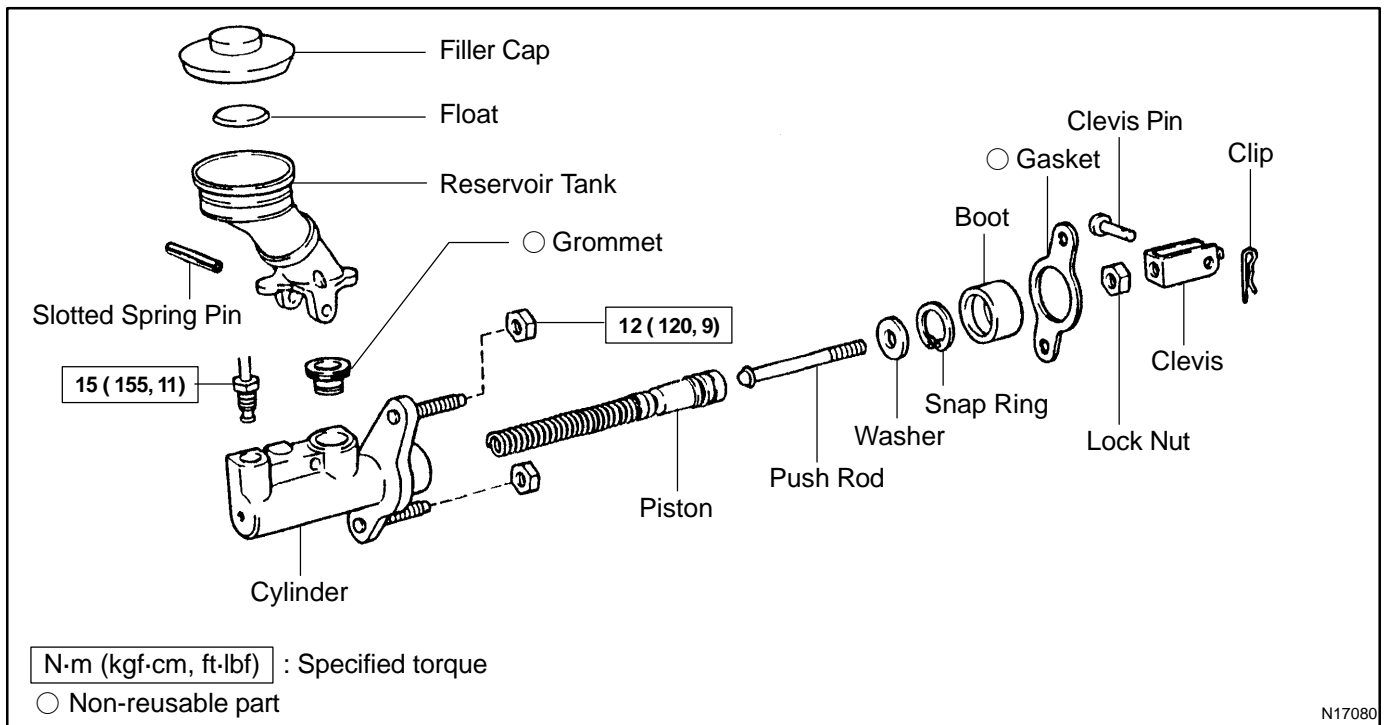

The procedures are presented in a step-by-step format:

- The illustration shows what to do and where to do it.
- The task heading tells what to do.
- The detailed text tells how to perform the task and gives other information such as specifications and warnings.

Example:

*Illustration:
what to do and where*

Task heading : what to do

21. CHECK PISTON STROKE OF OVERDRIVE BRAKE

(a) Place SST and a dial indicator onto the overdrive brake piston as shown in the illustration.

SST 09350-30020 (09350-06120)

Set part No.

Component part No.

Detailed text : how to do task

(b) Measure the stroke applying and releasing the compressed air (392 - 785 kPa, 4 - 8 kgf.cm² or 57 - 114 psi) as shown in the illustration.

Piston stroke: 1.40 — 1.70 mm (0.0551 — 0.0669 in.)

Specification

This format provides the experienced technician with a FAST TRACK to the information needed. The upper case task heading can be read at a glance when necessary, and the text below it provides detailed information. Important specifications and warnings always stand out in bold type.

6. REFERENCES

References have been kept to a minimum. However, when they are required you are given the page to refer to.

7. SPECIFICATIONS

Specifications are presented in bold type throughout the text where needed. You never have to leave the procedure to look up your specifications. They are also found in Service Specifications section, for quick reference.

- CAUTIONS are presented in bold type, and indicate there is a possibility of injury to you or other people.
- NOTICES are also presented in bold type, and indicate the possibility of damage to the components being repaired.
- HINTS are separated from the text but do not appear in bold. They provide additional information to help you perform the repair efficiently.

8. SI UNIT

The UNITS given in this manual are primarily expressed according to the SI UNIT (International System of Unit), and alternately expressed in the metric system and in the English System.

Example:

Torque: 30 N·m (310 kgf·cm, 22 ft·lbf)

IDENTIFICATION INFORMATION

VEHICLE IDENTIFICATION AND ENGINE SERIAL NUMBER

IN04B-01

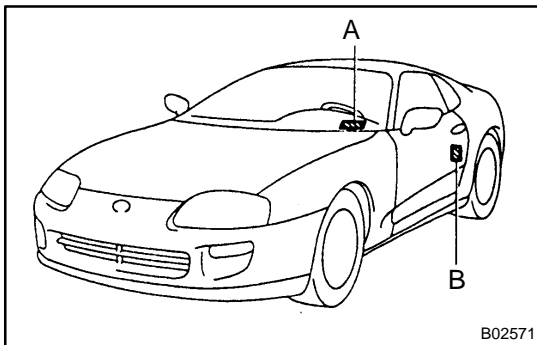

1. VEHICLE IDENTIFICATION NUMBER

The vehicle identification number is stamped on the vehicle identification number plate and certification label.

A: Vehicle Identification Number plate

B: Certification Label

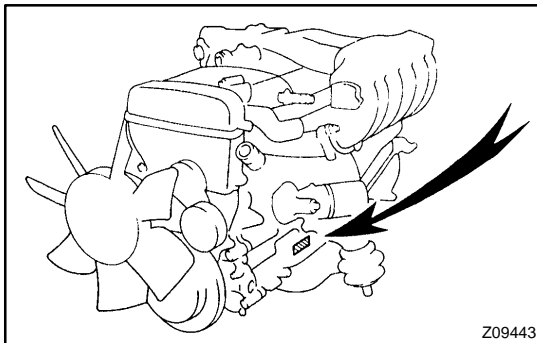

2. ENGINE SERIAL NUMBER

The engine serial number is stamped on the engine block as shown.

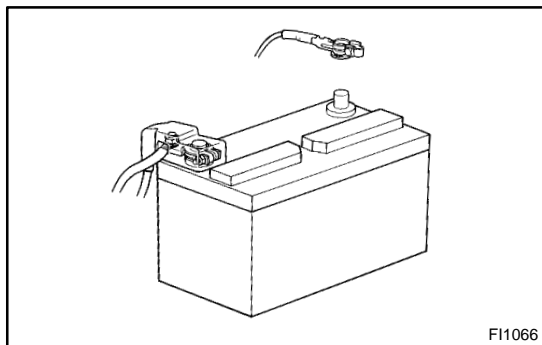

REPAIR INSTRUCTIONS

GENERAL INFORMATION

IN04C-01

1. BASIC REPAIR HINT

- (a) Use fender, seat and floor covers to keep the vehicle clean and prevent damage.
- (b) During disassembly, keep parts in the appropriate order to facilitate reassembly.
- (c) Observe the following:
 - (1) Before performing electrical work, disconnect the negative (-) terminal cable from the battery.
 - (2) If it is necessary to disconnect the battery for inspection or repair, always disconnect the negative (-) terminal cable which is grounded to the vehicle body.
 - (3) To prevent damage to the battery terminal, loosen the cable nut and raise the cable straight up without twisting or prying it.
 - (4) Clean the battery terminals and cable ends with a clean shop rag. Do not scrape them with a file or other abrasive objects.
 - (5) Install the cable ends to the battery terminals with the nut loose, and tighten the nut after installation. Do not use a hammer to tap the cable ends onto the terminals.
 - (6) Be sure the cover for the positive (+) terminal is properly in place.
- (d) Check hose and wiring connectors to make sure that they are secure and correct.
- (e) Non-reusable parts
 - (1) Always replace cotter pins, gaskets, O-rings and oil seals etc. with new ones.
 - (2) Non-reusable parts are indicated in the component illustrations by the "○" symbol.
- (f) Precoated parts

Precoated parts are bolts and nuts, etc. that are coated with a seal lock adhesive at the factory.

 - (1) If a precoated part is retightened, loosened or caused to move in any way, it must be recoated with the specified adhesive.
 - (2) When reusing precoated parts, clean off the old adhesive and dry with compressed air. Then apply the specified seal lock adhesive to the bolt, nut or threads.
 - (3) Precoated parts are indicated in the component illustrations by the "●" symbol.
- (g) When necessary, use a sealer on gaskets to prevent leaks.

- (h) Carefully observe all specifications for bolt tightening torques. Always use a torque wrench.
- (i) Use of special service tools (SST) and special service materials (SSM) may be required, depending on the nature of the repair. Be sure to use SST and SSM where specified and follow the proper work procedure. A list of SST and SSM can be found in the preparation part at the front of each section in this manual.

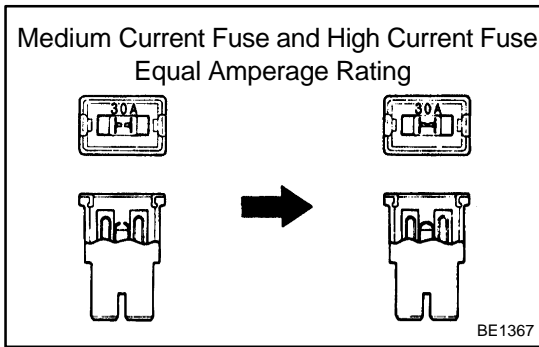

- (j) When replacing fuses, be sure the new fuse has the correct amperage rating. DO NOT exceed the rating or use one with a lower rating.

Illustration	Symbol	Part Name	Abbreviation
<p>BE5594</p>	<p>IN0365</p>	FUSE	FUSE
<p>BE5595</p>	<p>IN0366</p>	MEDIUM CURRENT FUSE	M-FUSE
<p>BE5596</p>	<p>IN0367</p>	HIGH CURRENT FUSE	H-FUSE
<p>BE5597</p>	<p>IN0367</p>	FUSIBLE LINK	FL
<p>BE5598</p>	<p>IN0368</p>	CIRCUIT BREAKER	CB

V00076

- (k) Care must be taken when jacking up and supporting the vehicle. Be sure to lift and support the vehicle at the proper locations (See page [IN-8](#)).
 - (1) If the vehicle is to be jacked up only at the front or rear end, be sure to block the wheels at the opposite end in order to ensure safety.
 - (2) After the vehicle is jacked up, be sure to support it on stands. It is extremely dangerous to do any work on a vehicle raised on a jack alone, even for a small job that can be finished quickly.

- (l) Observe the following precautions to avoid damage to the following parts:
 - (1) Do not open the cover or case of the ECU, ECM, PCM or TCM unless absolutely necessary. (If the IC terminals are touched, the IC may be destroyed by static electricity.)

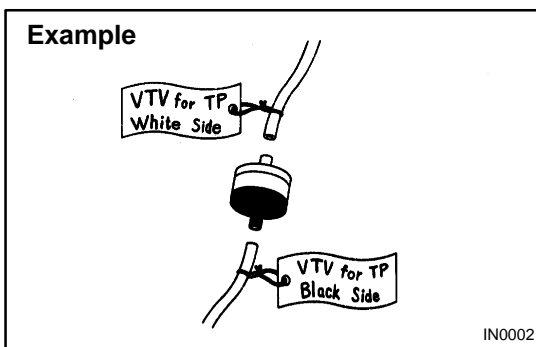
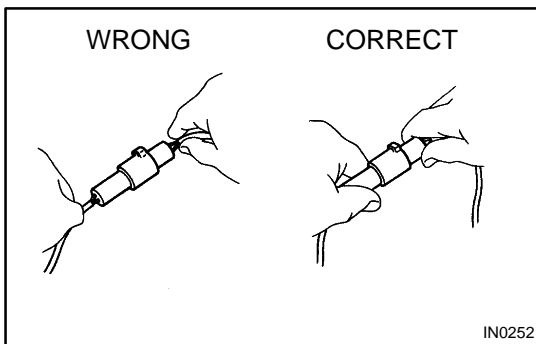
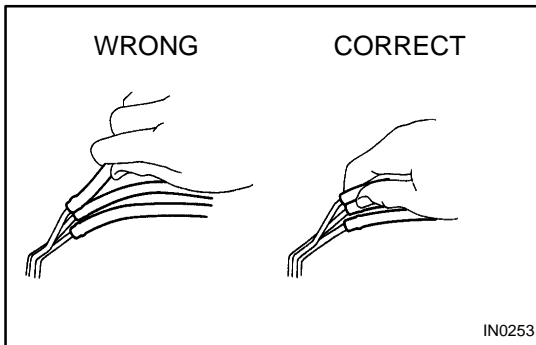

- (2) To disconnect vacuum hoses, pull on the end, not the middle of the hose.
 - (3) To pull apart electrical connectors, pull on the connector itself, not the wires.
 - (4) Be careful not to drop electrical components, such as sensors or relays. If they are dropped on a hard floor, they should be replaced and not reused.
 - (5) When steam cleaning an engine, protect the electronic components, air filter and emissions-related components from water.
 - (6) Never use an impact wrench to remove or install temperature switches or temperature sensors.
 - (7) When checking continuity at the wire connector, insert the tester probe carefully to prevent terminals from bending.
 - (8) When using a vacuum gauge, never force the hose onto a connector that is too large. Use a step-down adapter for adjustment. Once the hose has been stretched, it may leak.
- (m) Tag hoses before disconnecting them:
 - (1) When disconnecting vacuum hoses, use tags to identify how they should be reconnected.
 - (2) After completing a job, double check that the vacuum hoses are properly connected. A label under the hood shows the proper layout.
 - (n) Unless otherwise stated, all resistance is measured at an ambient temperature of 20°C (68°F). Because the resistance may be outside specifications if measured at high temperatures immediately after the vehicle has been running, measurements should be made when the engine has cooled down.

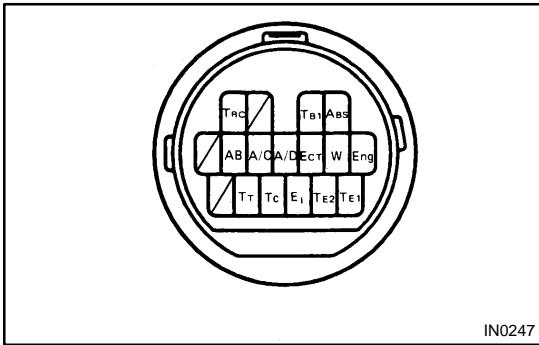
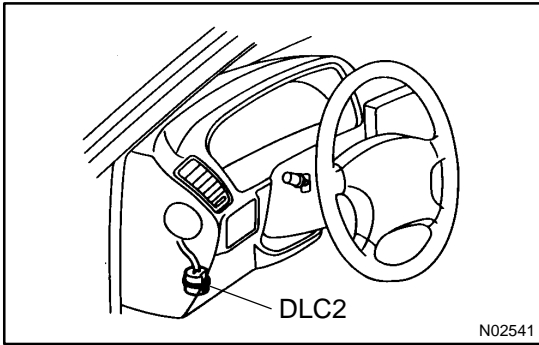

2. FOR VEHICLE WITH DATA LINK CONNECTOR 2 (DLC2)

- (a) The DLC2 is provided inside the cabin (located under the left side of instrument panel) as a connector exclusively for diagnosis of data from the engine, automatic transmission, ABS, A/C, Airbag, Traction Control and Cruise Control System to improve serviceability.
- (b) The DLC1 inside the engine compartment is used for engine adjustment.
- (c) Connecting the following terminals of the DLC2 to terminal E₁ selects the diagnosis mode shown in the table.

NOTICE:

Pay enough attention to the terminal connection position as this will cause a malfunction.

Terminal	System
T _{E1}	Engine and automatic transmission (Normal mode)
T _{E2} and T _{E1}	Engine and automatic transmission (Test mode)
T _C	ABS, A/C, Airbag, Traction Control and Cruise Control System
T _T	Automatic transmission

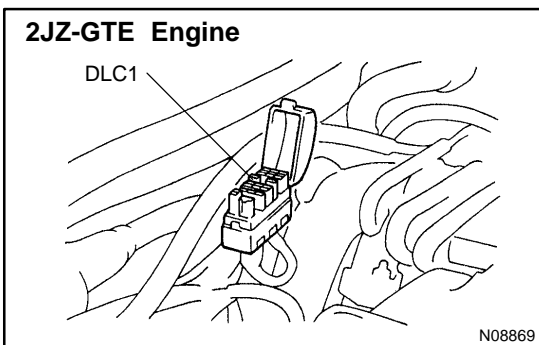
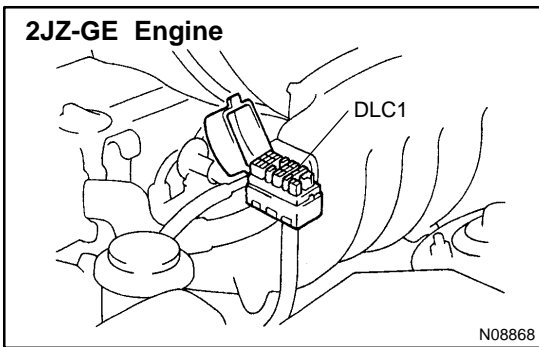

- (d) Refer to the respective system for the inspection method.

HINT:

By connecting the DLC2 up to a monitor specifically designed for use with the DLC2, the diagnosis result for each system can be read easily.

VEHICLE LIFT AND SUPPORT LOCATIONS

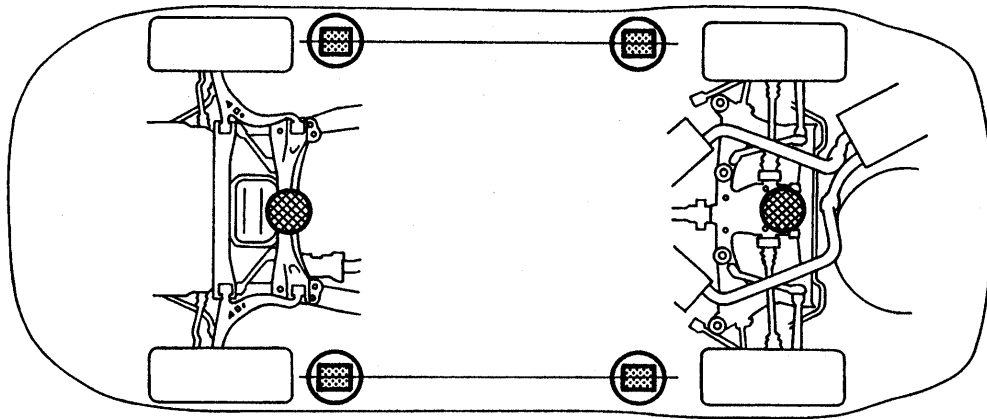

← Front

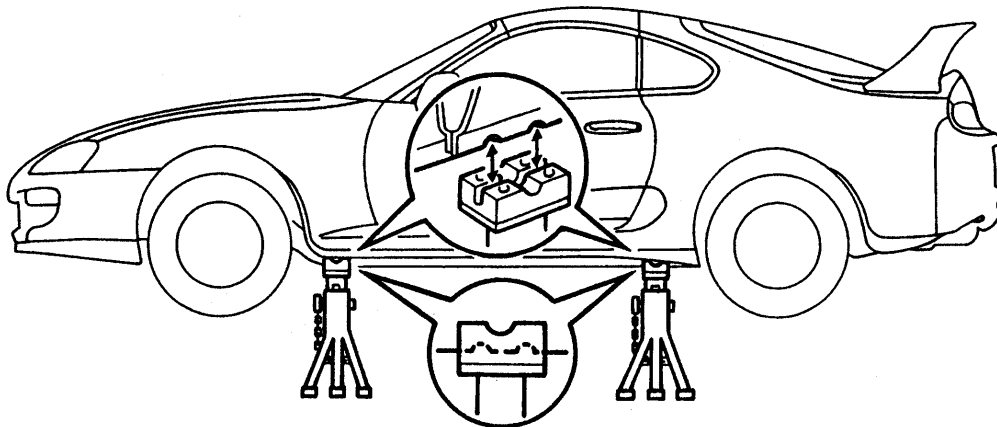

JACK POSITION _____ ●

Front Front crossmember

Rear Differential carrier

CAUTION:

Before jacking-up the rear and front, make sure the car is not carrying any extra weight.

PANTOGRAPH JACK POSITION _____ ○

SUPPORT POSITION

Safety stand and swing arm type lift ■

PLATE TYPE LIFT

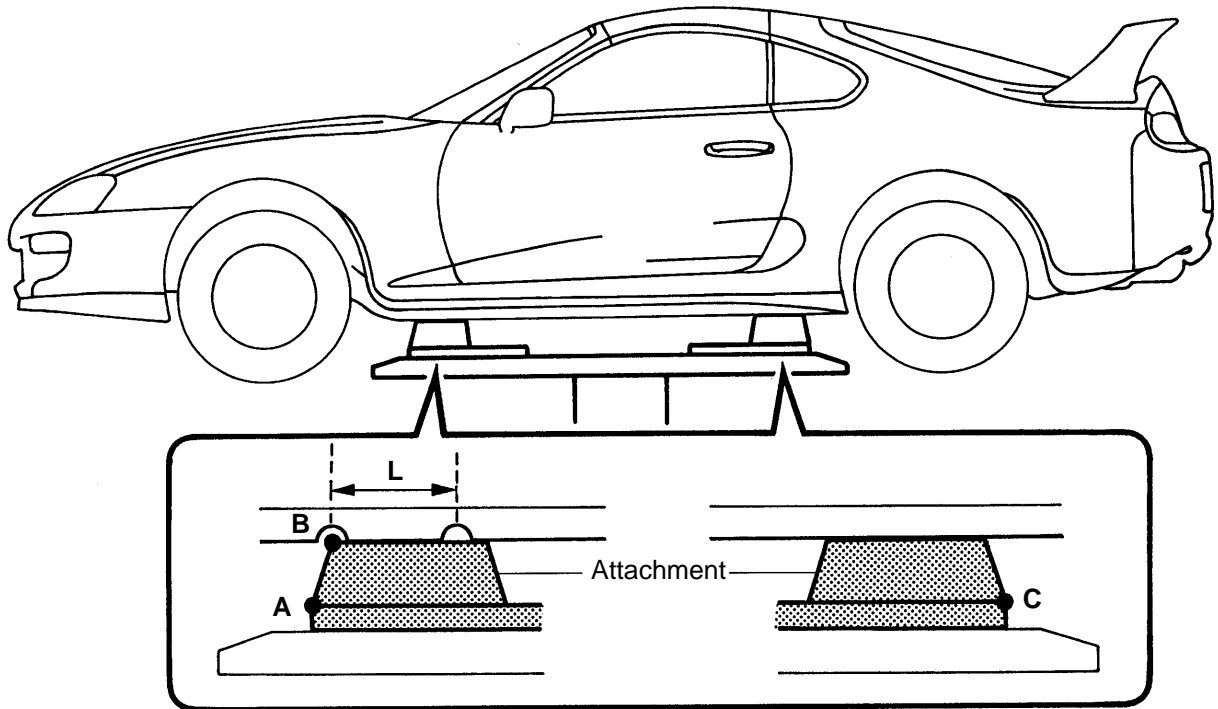

HINT:

Left and right set position

Place the vehicle over the center of the lift.

Front and rear set position

- Align the cushion gum ends of the plate with the attachment lower ends (A, C).
- Align the attachment upper end (B) with the front jack supporting point (L).

Attachment dimensions

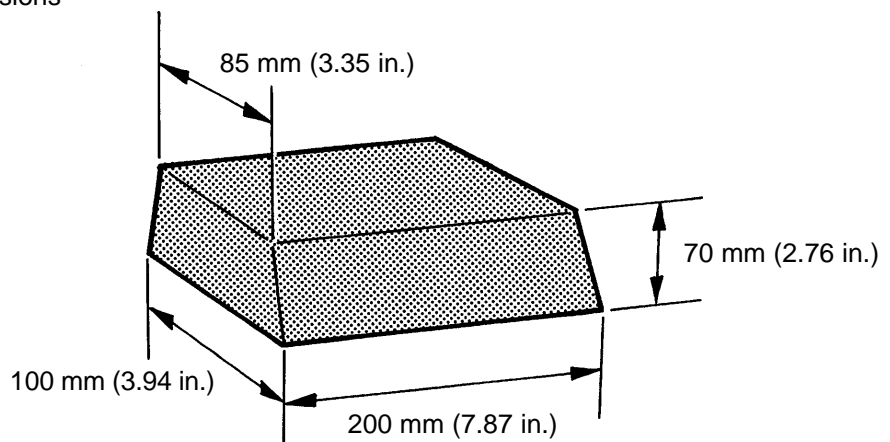

N19536

FOR ALL OF VEHICLES PRECAUTION

IN04E-02

1. FOR VEHICLES EQUIPPED WITH SRS AIRBAG

- (a) The TOYOTA SUPRA is equipped with an SRS (Supplemental Restraint System), such as the driver airbag, front passenger airbag.

Failure to carry out service operations in the correct sequence could cause the supplemental restraint system to unexpectedly deploy during servicing, possibly leading to a serious accident.

Further, if a mistake is made in servicing the supplemental restraint system, it is possible the SRS may fail to operate when required. Before servicing (including removal or installation of parts, inspection or replacement), be sure to read the following items carefully, then follow the correct procedure described in this manual.

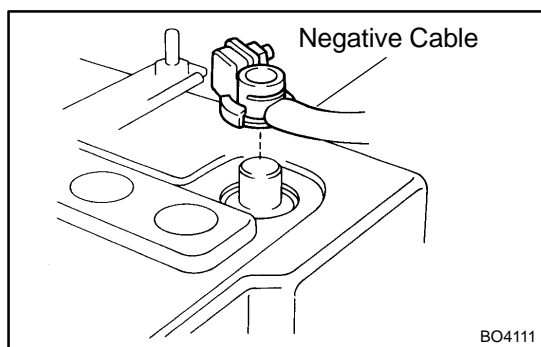

(b) GENERAL NOTICE

- (1) Malfunction symptoms of the supplemental restraint system are difficult to confirm, so the diagnostic trouble codes become the most important source of information when troubleshooting. When troubleshooting the supplemental restraint system, always inspect the diagnostic trouble codes before disconnecting the battery (See page [DI-555](#)).

- (2) Work must be started after 90 seconds from the time the ignition switch is turned to the "LOCK" position and the negative (-) terminal cable is disconnected from the battery.

(The supplemental restraint system is equipped with a back-up power source so that if work is started within 90 seconds of disconnecting the negative (-) terminal cable from the battery, the SRS may deploy.)

When the negative (-) terminal cable is disconnected from the battery, memory of the clock and audio systems will be cancelled. So before starting work, make a record of the contents memorized by the audio memory system. Then when work is finished, reset the clock and audio systems as before. To avoid erasing the memory of each memory system, never use a back-up power supply from outside the vehicle.

- (3) Even in cases of a minor collision where the SRS does not deploy, the steering wheel pad, front passenger airbag assembly and front airbag sensor should be inspected (See page [SR-8](#), [RS-22](#), [RS-34](#)).
- (4) Never use SRS parts from another vehicle. When replacing parts, replace them with new parts.
- (5) Before repairs, remove the airbag sensor if shocks are likely to be applied to the sensor during repairs.
- (6) Never disassemble and repair the airbag sensor assembly, steering wheel pad or front passenger airbag assembly in order to reuse it.
- (7) If the airbag sensor assembly, steering wheel pad or front passenger airbag assembly have been dropped, or if there are cracks, dents or other defects in the case, bracket or connector, replace them with new ones.
- (8) Do not expose the airbag sensor assembly, steering wheel pad and front passenger airbag assembly directly to hot air or flames.
- (9) Use a volt/ohmmeter with high impedance (10 k Ω /V minimum) for troubleshooting of the electrical circuit.
- (10) Information labels are attached to the periphery of the SRS components. Follow the instructions on the notices.
- (11) After work on the supplemental restraint system is completed, check the SRS warning light (See page [RS-1](#)).

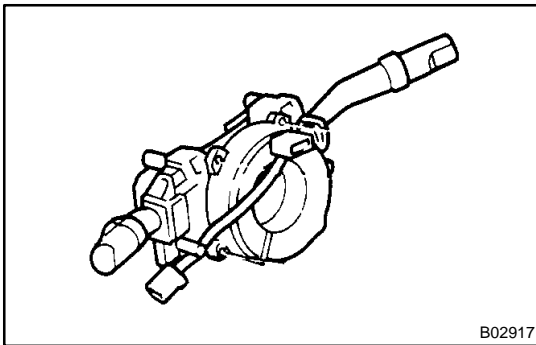

- (c) SPIRAL CABLE (in Combination Switch)
 The steering wheel must be fitted correctly to the steering column with the spiral cable at the neutral position, otherwise cable disconnection and other troubles may result. Refer to of this manual concerning correct steering wheel installation.

(d) STEERING WHEEL PAD (with Airbag)

- (1) When removing the steering wheel pad or handling a new steering wheel pad, it should be placed with the pad top surface facing up.

In this case, the twin-lock type connector lock lever should be in the locked state and care should be taken to place it so the connector will not be damaged. In addition do not store a steering wheel pad on top of another one. Storing the pad with its metallic surface facing upward may lead to a serious accident if the airbag inflates for some reason.

- (2) Never measure the resistance of the airbag squib. (This may cause the airbag to deploy, which is very dangerous.)
- (3) Grease should not be applied to the steering wheel pad and the pad should not be cleaned with detergents of any kind.
- (4) Store the steering wheel pad where the ambient temperature remains below 93°C (200°F), without high humidity and away from electrical noise.
- (5) When using electric welding, first disconnect the airbag connector (yellow color and 2 pins) under the steering column near the combination switch connector before starting work.
- (6) When disposing of a vehicle or the steering wheel pad alone, the airbag should be deployed using an SST before disposal (See page RS-1 1). Carry out the operation in a safe place away from electrical noise.

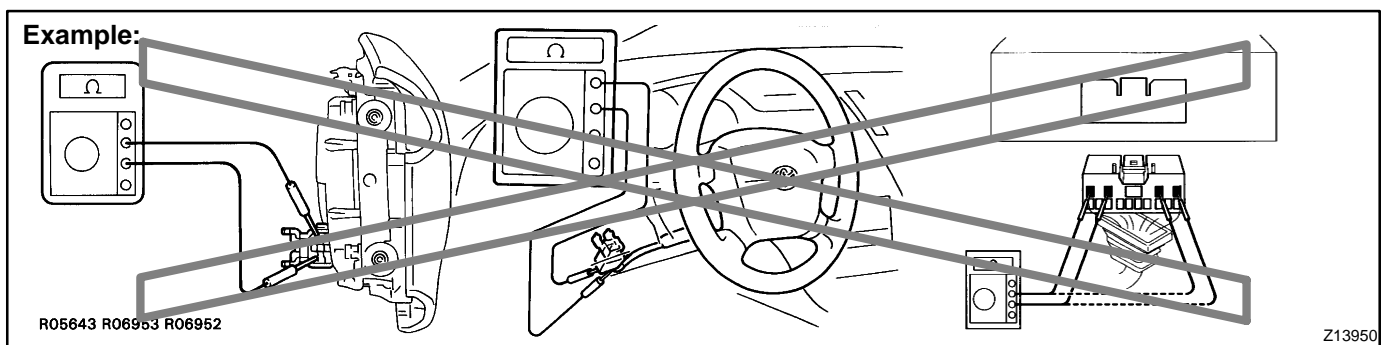
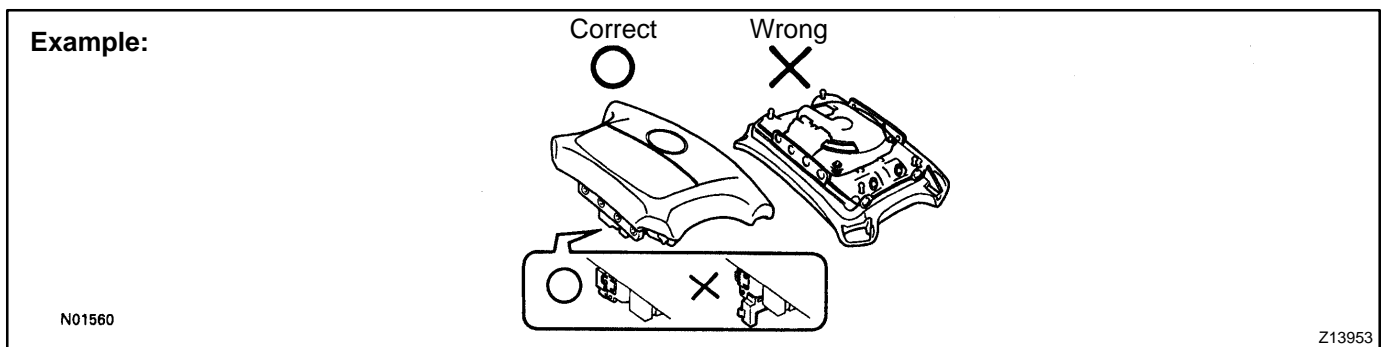

(e) FRONT PASSENGER AIRBAG ASSEMBLY

- (1) Always store a removed or new front passenger airbag assembly with the airbag deployment direction facing up.
Storing the airbag assembly with the airbag deployment direction facing down could cause a serious accident if the airbag inflates.
- (2) Never measure the resistance of the airbag squib. (This may cause the airbag deploy, which is very dangerous.)
- (3) Grease should not be applied to the front passenger airbag assembly and the airbag door should not be cleaned with detergents of any kind.
- (4) Store the airbag assembly where the ambient temperature remains below 93°C (200°F), without high humidity and away from electrical noise.
- (5) When using electric welding, first disconnect the airbag connector (yellow color and 2 pins) installed on the glove compartment finish plate at the left side of the glove compartment before starting work.
- (6) When disposing of a vehicle or the airbag assembly alone, the airbag should be deployed using an SST before disposal (See page RS-24).
Perform the operation in a safe place away from electrical noise.

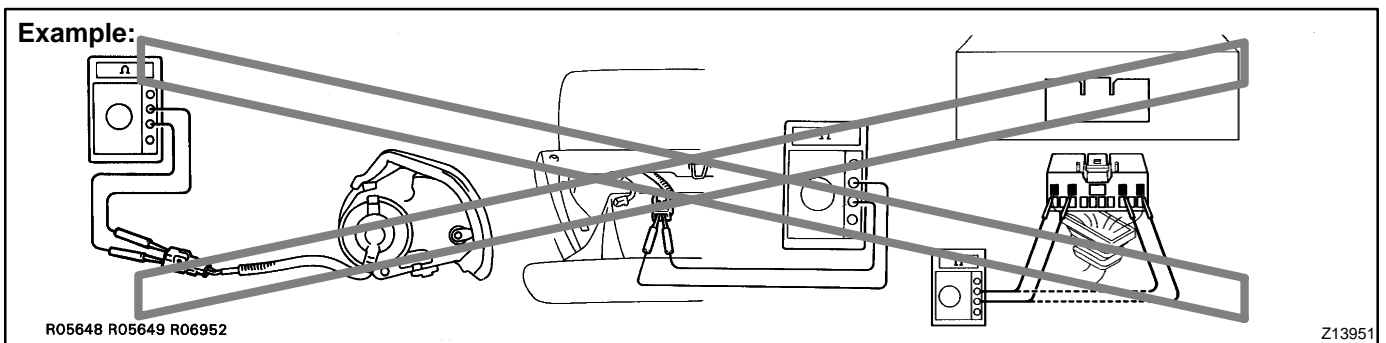
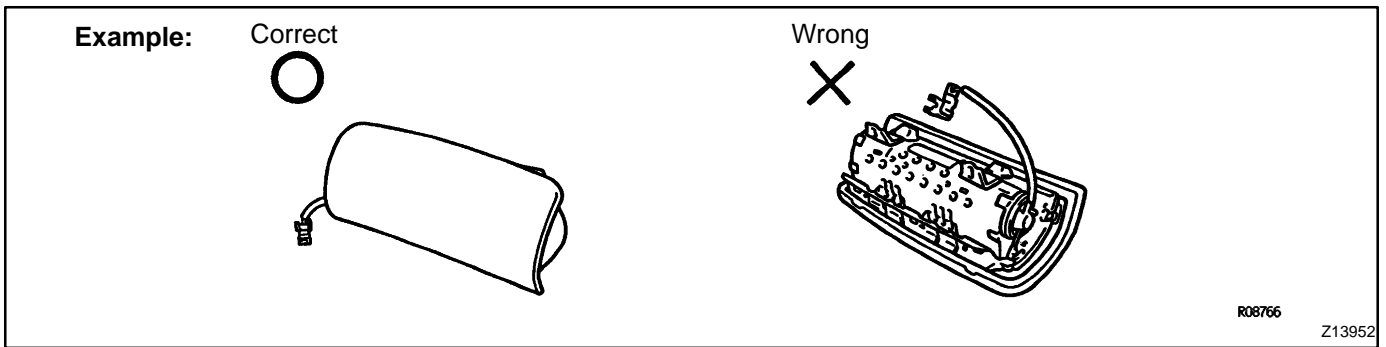

- (f) **AIRBAG SENSOR ASSEMBLY**
 - (1) Never reuse the airbag sensor assembly involved in a collision when the SRS has deployed.
 - (2) The connectors to the airbag sensor assembly should be connected or disconnected with the sensor mounted on the floor. If the connectors are connected or disconnected while the airbag sensor assembly is not mounted to the floor, it could cause undesired ignition of the supplemental restraint system.
 - (3) Work must be started after 90 seconds from the time the ignition switch is turned to the "LOCK" position and the negative (-) terminal cable is disconnected from the battery, even if only loosening the set bolts of the airbag sensor assembly.
- (g) **WIRE HARNESS AND CONNECTOR**
 The SRS wire harness is integrated with the cowl wire harness assembly and floor wire harness assembly. The wires for the SRS wire harness are encased in a yellow corrugated tube. All the connectors for the system are also a standard yellow color. If the SRS wire harness becomes disconnected or the connector becomes broken due to an accident, etc., repair or replace it as shown on page [RS-38](#) .

2. FOR VEHICLES EQUIPPED WITH A CATALYTIC CONVERTER

If large amounts of unburned gasoline flow into the converter, it may overheat and create a fire hazard. To prevent this, observe the following precautions and explain them to your customer.

- (a) Use only unleaded gasoline.
- (b) Avoid prolonged idling.
Avoid running the engine at idle speed for more than 20 minutes.
- (c) Avoid spark jump test.
 - (1) Perform spark jump test only when absolutely necessary. Perform this test as rapidly as possible.
 - (2) While testing, never race the engine.
- (d) Avoid prolonged engine compression measurement.
Engine compression tests must be done as rapidly as possible.
- (e) Do not run engine when fuel tank is nearly empty.
This may cause the engine to misfire and create an extra load on the converter.
- (f) Avoid coasting with ignition turned off and prolonged braking.
- (g) Do not dispose of used catalyst along with parts contaminated with gasoline or oil.

3. IF VEHICLE IS EQUIPPED WITH MOBILE COMMUNICATION SYSTEM

- (a) For vehicles with mobile communication systems such as two-way radios and cellular telephones, observe the following precautions.
- (b) Install the antenna as far as possible away from the ECU and sensors of the vehicle's electronic system.

- (c) Install the antenna feeder at least 20 cm (7.87 in.) away from the ECU and sensors of the vehicle's electronics systems. For details about ECU and sensors locations, refer to the section on the applicable component.
- (d) Do not wind the antenna feeder together with the other wiring. As much as possible, also avoid running the antenna feeder parallel with other wire harnesses.
- (e) Confirm that the antenna and feeder are correctly adjusted.
- (f) Do not install powerful mobile communications system.

4. FOR USING OBDII SCAN TOOL OR TOYOTA HAND-HELD TESTER

Observe the following for safety reasons:

- Before using the OBDII scan tool or TOYOTA hand-held tester, the OBDII scan tool's instruction book or TOYOTA hand-held tester's operator manual should be read thoroughly.
- Be sure to route all cables securely when driving with the OBDII scan tool or TOYOTA hand-held tester connected to the vehicle. (i.e. Keep cables away from feet, pedals, steering wheel and shift lever.)
- Two persons are required when test driving with the OBDII scan tool or TOYOTA hand-held tester, one person to drive the vehicle and one person to operate the OBDII scan tool or TOYOTA hand-held tester.

5. FOR VEHICLES EQUIPPED WITH TRACTION CONTROL (TRAC) SYSTEM

When using a 2 wheel drum tester such as a speedometer tester or chassis dynamometer, etc., or jacking up the rear wheels and driving the wheels, always push in the TRAC cut ("TRAC OFF") switch and turn the TRAC system OFF.

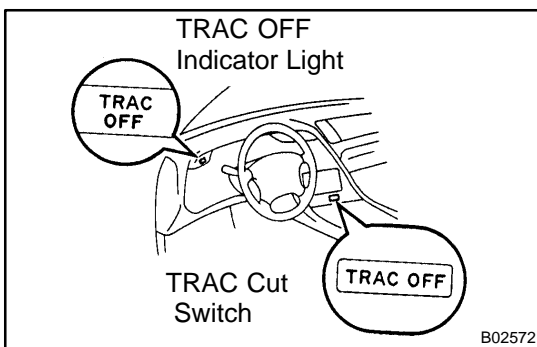

- (a) Confirm TRAC system is OFF
 - (1) Press the TRAC cut ("TRAC OFF") switch.
 - (2) Check that the TRAC OFF indicator light comes on when the TRAC system is turned off by the TRAC cut switch.

HINT:

The TRAC OFF indicator light should always operate right after the engine is restarted.

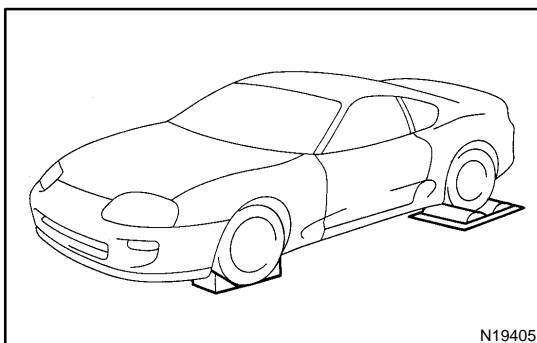

- (3) Begin measurements.

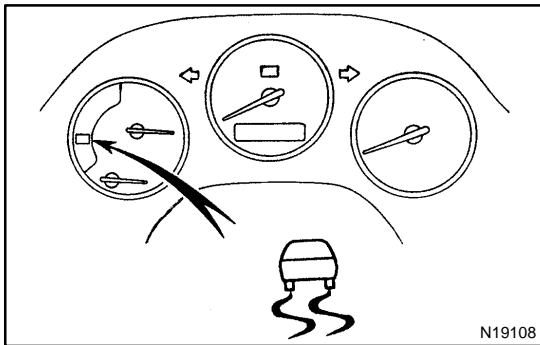

- (4) Press the TRAC cut switch again to change the TRAC to operative and check that the TRAC OFF indicator light goes off.

HINT:

The SLIP indicator light blinks when the TRAC system is operative.

6. INSPECTION AND ADJUSTMENT OF JOINT ANGLE DURING REMOVAL AND INSTALLATION OF PROPELLER SHAFT

When performing operations which involve the removal and installation of the propeller shaft, always check the joint angle. Make adjustments if necessary (See page [PR-14](#)).

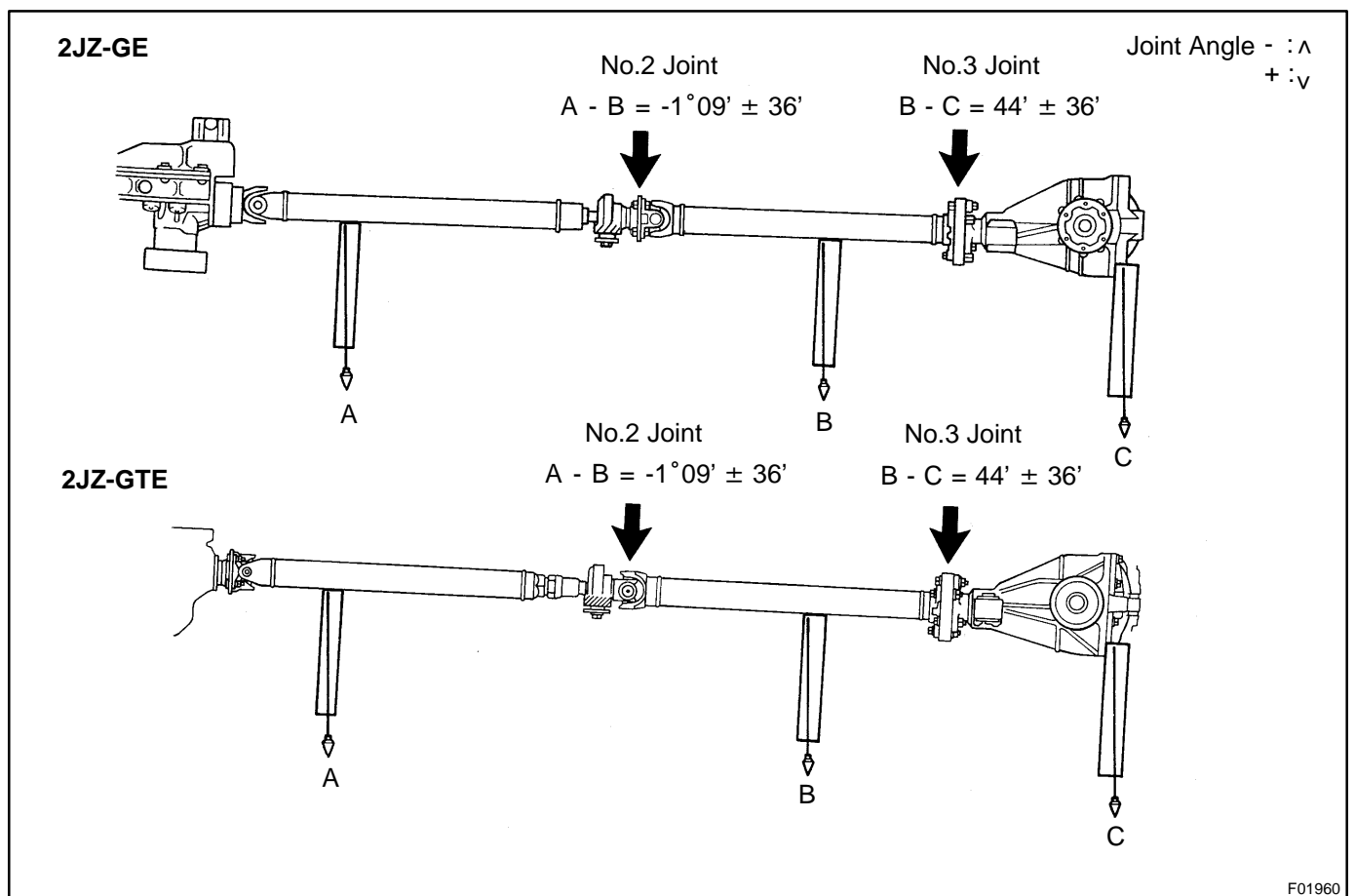

HOW TO TROUBLESHOOT ECU CONTROLLED SYSTEMS

GENERAL INFORMATION

IN04F-02

A large number of ECU controlled systems are used in the TOYOTA SUPRA. In general, the ECU controlled system is considered to be a very intricate system requiring a high level of technical knowledge and expert skill to troubleshoot. However, the fact is that if you proceed to inspect the circuits one by one, troubleshooting of these systems is not complex. If you have adequate understanding of the system and a basic knowledge of electricity, accurate diagnosis and necessary repair can be performed to locate and fix the problem. This manual is designed through emphasis of the above standpoint to help service technicians perform accurate and effective troubleshooting, and is compiled for the following major ECU controlled systems:

System	Page
1. Engine (2JZ-GE)	DI-1
2. Engine (2JZ-GTE)	DI-145
3. Automatic Transmission (2JZ-GE)	DI-316
4. Automatic Transmission (2JZ-GTE)	DI-371
5. Anti-Lock Brake System	DI-440
6. ABS & Traction control System	DI-499
7. Supplemental Restraint System	DI-555
8. Theft Deterrent System	DI-608
9. Cruise Control System	DI-660
11. Air Conditioning System	DI-711

The troubleshooting procedure and how to make use of it are described on the above pages.

FOR USING OBDII SCAN TOOL OR TOYOTA HAND-HELD TESTER

- Before using the OBDII scan tool or TOYOTA hand-held tester, the OBDII scan tool's instruction book or TOYOTA hand-held tester's operator manual should be read thoroughly.
- If the OBDII scan tool or TOYOTA hand-held tester cannot communicate with ECU controlled systems when you have connected the cable of the OBDII scan tool or TOYOTA hand-held tester to DLC3, turned the ignition switch ON and operated the scan tool, there is a problem on the vehicle side or tool side.
 - (1) If communication is normal when the tool is connected to another vehicle, inspect the diagnosis data link line (Bus \oplus line) or ECU power circuit of the vehicle.
 - (2) If communication is still not possible when the tool is connected to another vehicle, the problem is probably in the tool itself, so perform the Self Test procedures outlined in the Tester Operator's Manual.

HOW TO PROCEED WITH TROUBLESHOOTING

Carry out troubleshooting in accordance with the procedure on the following page. Here, only the basic procedure is shown. Details are provided in the DI section, showing the most effective methods for each circuit. Confirm the troubleshooting procedures first for the relevant circuit before beginning troubleshooting of that circuit.

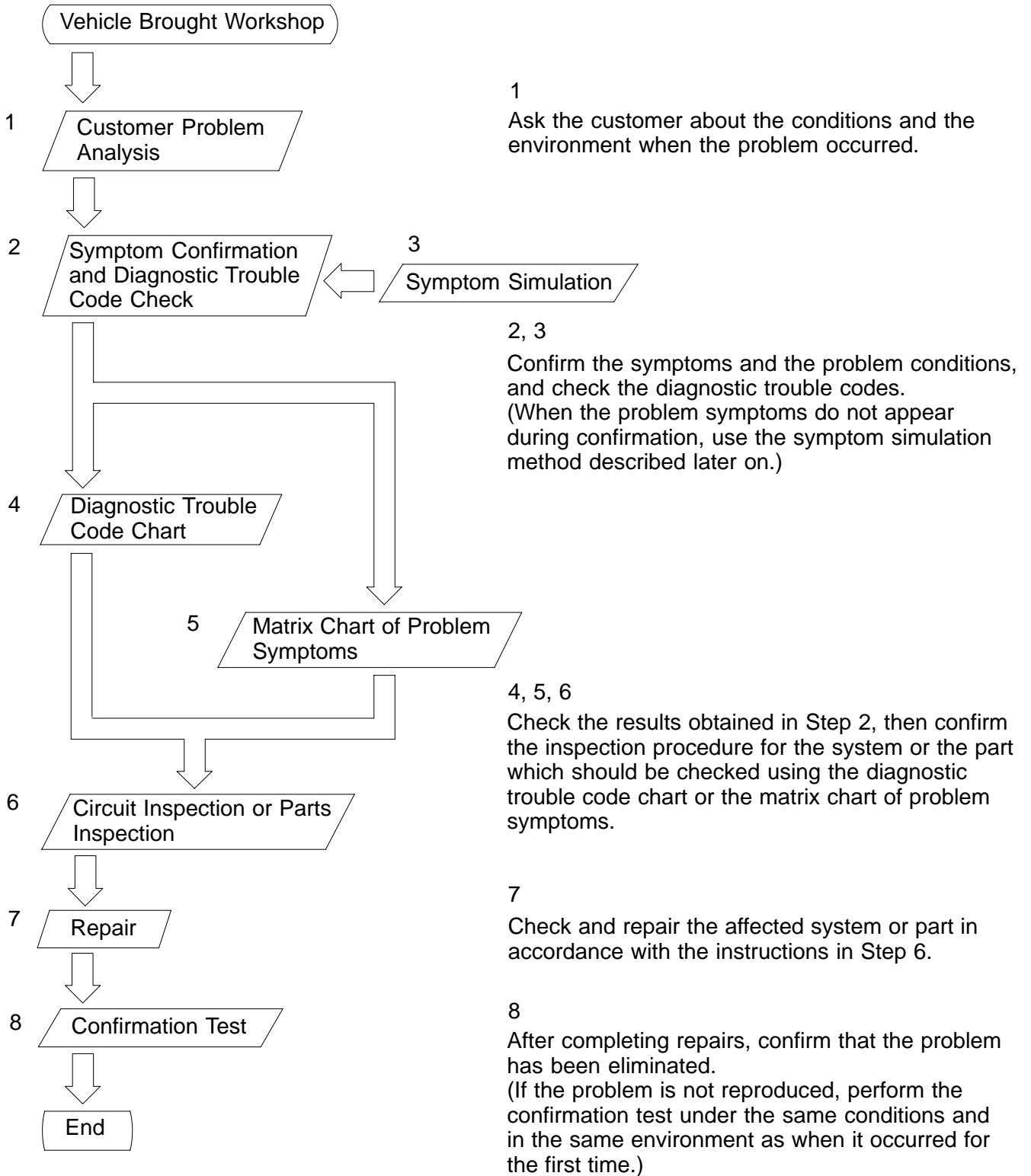

1. CUSTOMER PROBLEM ANALYSIS

In troubleshooting, the problem symptoms must be confirmed accurately and all preconceptions must be cleared away in order to give an accurate judgment. To ascertain just what the problem symptoms are, it is extremely important to ask the customer about the problem and the conditions at the time it occurred.

Important Point in the Problem Analysis:

The following 5 items are important points in the problem analysis. Past problems which are thought to be unrelated and the repair history, etc. may also help in some cases, so as much information as possible should be gathered and its relationship with the problem symptoms should be correctly ascertained for reference in troubleshooting. A customer problem analysis table is provided in the troubleshooting section for each system for your use.

Important Points in the Customer Problem Analysis

- What ----- Vehicle model, system name
- When ----- Date, time, occurrence frequency
- Where ----- Road conditions
- Under what conditions? ----- Running conditions, driving conditions, weather conditions
- How did it happen? ----- Problem symptoms

(Sample) Engine control system check sheet.

CUSTOMER PROBLEM ANALYSIS CHECK				
ENGINE CONTROL SYSTEM Check Sheet		Inspector's Name _____		
Customer's Name		Model and Model Year		
Driver's Name		Frame No.		
Data Vehicle Brought in		Engine Model		
License No.		Odometer Reading	km miles	
Problem Symptoms	<input type="checkbox"/> Engine does not Start	<input type="checkbox"/> Engine does not crank	<input type="checkbox"/> No initial combustion	
	<input type="checkbox"/> Difficult to Start	<input type="checkbox"/> No complete combustion		
	<input type="checkbox"/> Poor Idling	<input type="checkbox"/> Engine cranks slowly	<input type="checkbox"/> Other _____	
	<input type="checkbox"/> Poor Drive ability	<input type="checkbox"/> Incorrect first idle	<input type="checkbox"/> Idling rpm is abnormal	<input type="checkbox"/> High (rpm) <input type="checkbox"/> Low (rpm)
	<input type="checkbox"/> Engine Stall	<input type="checkbox"/> Rough idling	<input type="checkbox"/> Other _____	
	<input type="checkbox"/> Others	<input type="checkbox"/> Hesitation	<input type="checkbox"/> Back fire	<input type="checkbox"/> Muffler explosion (after-fire) <input type="checkbox"/> Surging
		<input type="checkbox"/> Knocking	<input type="checkbox"/> Other _____	
		<input type="checkbox"/> Soon after starting	<input type="checkbox"/> After accelerator pedal depressed	
		<input type="checkbox"/> After accelerator pedal released	<input type="checkbox"/> During A/C operation	
		<input type="checkbox"/> Shifting from N to D	<input type="checkbox"/> Other _____	
<input type="checkbox"/> constant <input type="checkbox"/> Sometimes (times per day/month)				

2. SYMPTOM CONFIRMATION AND DIAGNOSTIC TROUBLE CODE CHECK

The diagnostic system in the TOYOTA SUPRA fulfills various functions. The first function is the Diagnostic Trouble Code Check in which a malfunction in the signal circuits to the ECU is stored in code in the ECU memory at the time of occurrence, to be output by the technician during troubleshooting. Another function is the Input Signal Check which checks if the signals from various switches are sent to the ECU correctly. By using these check functions, the problem areas can be narrowed down quickly and troubleshooting can be performed effectively. Diagnostic functions are incorporated in the following systems in the TOYOTA SUPRA.

System	Diagnostic Trouble Code Check	Input Signal Check (Sensor Check)	Other Diagnosis Function
Engine	<input type="radio"/> (with Check Mode)	<input type="radio"/>	Diagnostic Test Mode
Automatic Transmission	<input type="radio"/> (with Check Mode)	<input type="radio"/>	Diagnostic Test Mode
Anti-Lock Brake System	<input type="radio"/>	<input type="radio"/>	
ABS & Traction Control System	<input type="radio"/>	<input type="radio"/>	
Supplemental Restraint System	<input type="radio"/>		
Cruise Control	<input type="radio"/>	<input type="radio"/>	
Air Conditioning	<input type="radio"/>	<input type="radio"/>	Actuator Check

In diagnostic trouble code check, it is very important to determine whether the problem indicated by the diagnostic trouble code is still occurring or occurred in the past but returned to normal at present. In addition, it must be checked in the problem symptom check whether the malfunction indicated by the diagnostic trouble code is directly related to the problem symptom or not. For this reason, the diagnostic trouble codes should be checked before and after the symptom confirmation to determine the current conditions, as shown in the table below. If this is not done, it may, depending on the case, result in unnecessary troubleshooting for normally operating systems, thus making it more difficult to locate the problem, or in repairs not pertinent to the problem. Therefore, always follow the procedure in correct order and perform the diagnostic trouble code check.

DIAGNOSTIC TROUBLE CODE CHECK PROCEDURE

Diagnostic Trouble Code Check (Make a note of and then clear)	Confirmation of Symptoms	Diagnostic Trouble Code Check	Problem Condition
Diagnostic Trouble Code Display	Problem symptoms exist	Same diagnostic trouble code is displayed	Problem is still occurring in the diagnostic circuit.
	<div style="text-align: center;">→</div> No problem symptoms exist	Normal code is displayed	The problem is still occurring in a place other than in the diagnostic circuit. (The diagnostic trouble code displayed first is either for a past problem or it is a secondary problem.)
Normal Code Display	Problem symptoms exist	Normal code is displayed	The problem is still occurring in a place other than in the diagnostic circuit.
	<div style="text-align: center;">→</div> No problem symptoms exist	Normal code is displayed	The problem occurred in a place other than in the diagnostic circuit in the past.

Taking into account the above points, a flow chart showing how to proceed with troubleshooting using the diagnostic trouble code check is shown below. This flow chart shows how to utilize the diagnostic trouble code check effectively, then by carefully checking the results, indicates how to proceed either to diagnostic trouble code troubleshooting or to troubleshooting of problem symptoms.

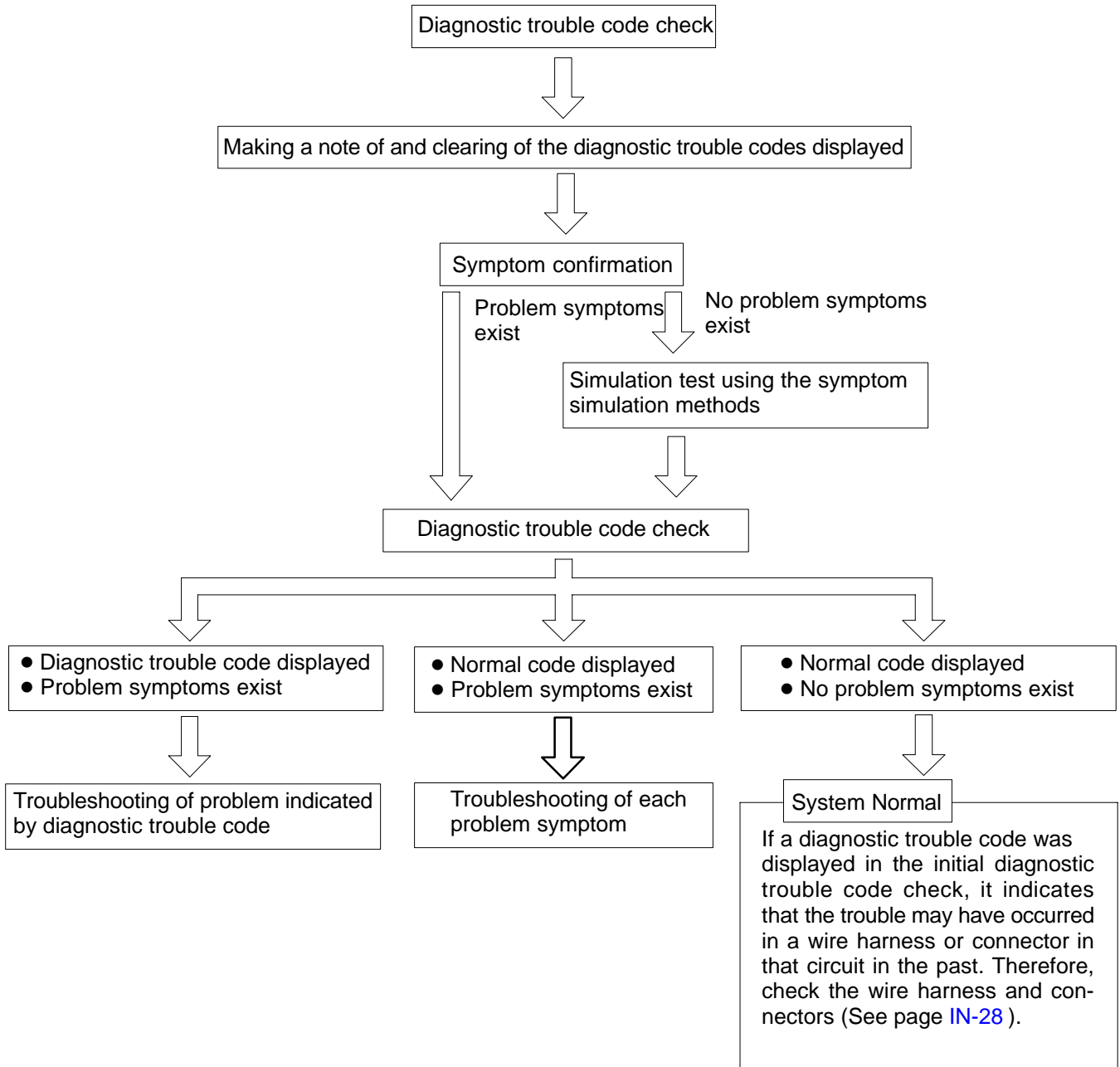

3. SYMPTOM SIMULATION

The most difficult case in troubleshooting is when there are no problem symptoms occurring. In such cases, a thorough customer problem analysis must be carried out, then simulate the same or similar conditions and environment in which the problem occurred in the customer's vehicle. No matter how much experience a technician has, or how skilled he may be, if he proceeds to troubleshoot without confirming the problem symptoms he will tend to overlook something important in the repair operation and make a wrong guess somewhere, which will only lead to a standstill. For example, for a problem which only occurs when the engine is cold, or for a problem which occurs due to vibration caused by the road during driving, etc., the problem can never be determined so long as the symptoms are confirmed with the engine hot condition or the vehicle at a standstill. Since vibration, heat or water penetration (moisture) are likely causes for problems which are difficult to reproduce, the symptom simulation tests introduced here are effective measures in that the external causes are applied to the vehicle in a stopped condition.

Important Points in the Symptom Simulation Test:

In the symptom simulation test, the problem symptoms should of course be confirmed, but the problem area or parts must also be found out. To do this, narrow down the possible problem circuits according to the symptoms before starting this test and connect a tester beforehand. After that, carry out the symptom simulation test, judging whether the circuit being tested is defective or normal and also confirming the problem symptoms at the same time. Refer to the matrix chart of problem symptoms for each system to narrow down the possible causes of the symptom.

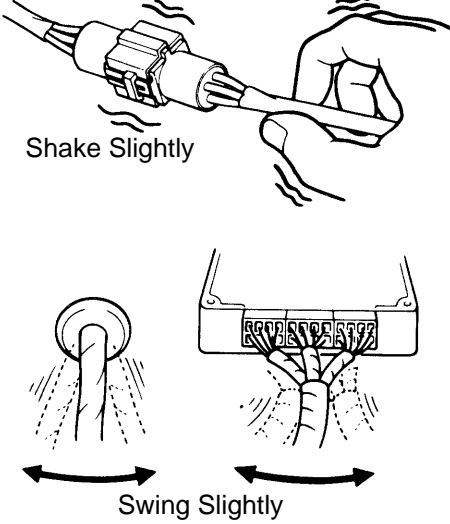
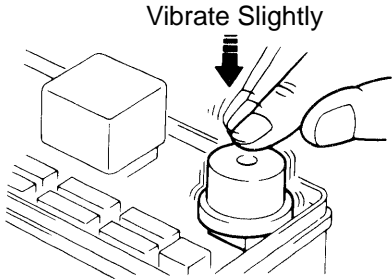
<p>1</p>	<p>VIBRATION METHOD: When vibration seems to be the major cause.</p>
<p>CONNECTORS Slightly shake the connector vertically and horizontally.</p> <p>WIRE HARNESS Slightly shake the wire harness vertically and horizontally. The connector joint, fulcrum of the vibration, and body through portion are the major areas to be checked thoroughly.</p>	 <p>The diagrams illustrate two vibration methods. The top diagram shows a hand holding a connector with wavy lines indicating vibration, labeled 'Shake Slightly'. The bottom diagram shows a hand holding a wire harness with arrows indicating swinging motion, labeled 'Swing Slightly'. Reference codes F12331 and F12332 are present.</p>
<p>PARTS AND SENSOR Apply slight vibration with a finger to the part of the sensor considered to be the problem cause and check if the malfunction occurs.</p> <p>HINT: Applying strong vibration to relays may result in open relays.</p>	 <p>The diagram shows a hand applying vibration to a cylindrical sensor component on a circuit board. A downward arrow indicates the direction of vibration, labeled 'Vibrate Slightly'. Reference code F12330 is present.</p>

V07268

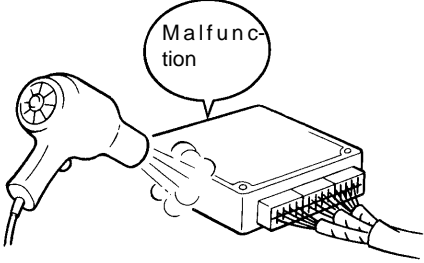
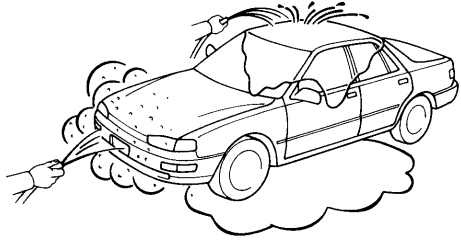
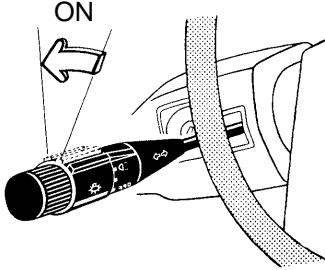
<p>2</p>	<p>HEAT METHOD: When the problem seems to occur when the suspect area is heated.</p>
<p>Heat the component that is the likely cause of the malfunction with a hair dryer or similar object. Check to see if the malfunction occurs.</p> <p>NOTICE:</p> <p>(1) Do not heat to more than 60 °C (140 °F). (Temperature is limited not to damage the components.)</p> <p>(2) Do not apply heat directly to parts in the ECU.</p>	 <p>F12334</p>
<p>3</p>	<p>WATER SPRINKLING METHOD: When the malfunction seems to occur on a rainy day or in a high-humidity condition.</p>
<p>Sprinkle water onto the vehicle and check to see if the malfunction occurs.</p> <p>NOTICE:</p> <p>(1) Never sprinkle water directly into the engine compartment, but indirectly change the temperature and humidity by applying water spray onto the radiator front surface.</p> <p>(2) Never apply water directly onto the electronic components.</p> <p>(Service hint) If a vehicle is subject to water leakage, the leaked water may contaminate the ECU. When testing a vehicle with a water leakage problem, special caution must be taken.</p>	 <p>F16649</p>
<p>4</p>	<p>OTHER: When a malfunction seems to occur when electrical load is excessive.</p>
<p>Turn on all electrical loads including the heater blower, head lights, rear window defogger, etc. and check to see if the malfunction occurs.</p>	 <p>F12336</p>

V07469

4. DIAGNOSTIC TROUBLE CODE CHART

The inspection procedure is shown in the table below. This table permits efficient and accurate troubleshooting using the diagnostic trouble codes displayed in the diagnostic trouble code check. Proceed with troubleshooting in accordance with the inspection procedure given in the diagnostic chart corresponding to the diagnostic trouble codes displayed. The engine diagnostic trouble code chart is shown below as an example.

● **DTC No.**
Indicates the diagnostic trouble code.

● **Page or Instructions**
Indicates the page where the inspection procedure for each circuit is to be found, or gives instructions for checking and repairs.

● **Trouble Area**
Indicates the suspect area of the problem.

● **Detection Item**
Indicates the system of the problem or contents of the problem.

DTC CHART (SAE Controlled)

HINT: Parameters listed in the chart may not be exactly the same as your reading due to the type of instrument or other factors.

If a malfunction code is displayed during the DTC check mode, check the circuit for that code listed in the table below. For details of each code, turn to the page referred to under the "See page" for the respective "DTC No." in the DTC chart.

DTC No. (See page)	Detection Item	Trouble Area	MIL*	Memory
P0100 (DI-23)	Mass Air Flow Circuit Malfunction	<ul style="list-style-type: none"> ● Open or short in mass air flow meter circuit ● Mass air flow meter ● ECM 	○	○
P0101 (DI-27)	Mass Air Flow Circuit Range/Performance Problem	<ul style="list-style-type: none"> ● Mass air flow meter 	○	○
P0110 (DI-28)	Intake Air Temp. Circuit Malfunction	<ul style="list-style-type: none"> ● Open or short in intake air temp. sensor circuit ● Intake air temp. sensor ● ECM 	○	○
P0115 (DI-32)	Engine Coolant Temp. Circuit Malfunction	<ul style="list-style-type: none"> ● Open or short in engine coolant temp. sensor circuit ● Engine coolant temp. sensor ● ECM 	○	○
P0116 (DI-36)	Engine Coolant Temp. Circuit Range/Performance Problem	<ul style="list-style-type: none"> ● Engine coolant temp. sensor ● Cooling system 	○	○
P0120 (DI-37)	Throttle/Pedal Position Sensor/Switch "A" Circuit Malfunction	<ul style="list-style-type: none"> ● Open or short in throttle position sensor circuit ● Throttle position sensor ● ECM 	○	○
	Throttle/Pedal Position Sensor/Switch Range/Performance	<ul style="list-style-type: none"> ● Throttle position sensor 		
	Intake Air Temp. for Closed	<ul style="list-style-type: none"> ● Open or short in heated oxygen sensor circuit ● Heated oxygen sensor 		

5. PROBLEM SYMPTOMS TABLE

The suspect circuits or parts for each problem symptom are shown in the table below. Use this table to troubleshooting the problem when a "Normal" code is displayed in the diagnostic trouble code check but the problem is still occurring. Numbers in the table indicate the inspection order in which the circuits or parts should be checked.

HINT:

When the problem is not detected by the diagnostic system even though the problem symptom is present, it is considered that the problem is occurring outside the detection range of the diagnostic system, or that the problem is occurring in a system other than the diagnostic system.

● Page
Indicates the page where the flow chart for each circuit is located.

● Circuit Inspection, Inspection Order
Indicates the circuit which needs to be checked for each problem symptom. Check in the order indicated by the numbers.

● Problem Symptom

● Circuit or Part Name
Indicates the circuit or part which needs to be checked.

PROBLEM SYMPTOMS TABLE

Symptom	Suspect Area	See page
Engine does not crank (Does not start)	1. Starter and starter relay	ST-14,ST-15
No initial combustion (Does not start)	1. ECM power source circuit 2. Fuel pump control circuit 3. Engine control module (ECM)	DI-144 DI-148 SF-67
No complete combustion (Does not start)	1. Fuel pump control circuit	DI-148
Engine cranks normally (Difficult to start)	1. Starter signal circuit 2. Fuel pump control circuit 3. Compression	DI-141 DI-148 EM-3
Cold engine (Difficult to start)	1. Starter signal circuit 2. Fuel pump control circuit	DI-141 DI-148
Hot engine	1. Starter signal circuit 2. Fuel pump control circuit	DI-141 DI-148
	1. A/C signal circuit (Compressor circuit) 2. ECM power source circuit	DI-825
	1. A/C signal circuit 2. Fuel pump control circuit	
	1. Compression 2. Fuel pump control circuit	

6. CIRCUIT INSPECTION

How to read and use each page is shown below.

● Diagnostic Trouble Code No. and Detection Item

● Circuit Description
The major role and operation, etc. of the circuit and its component parts are explained.

DTC	P0325	Knock Sensor 1 Circuit Malfunction
------------	--------------	---

CIRCUIT DESCRIPTION
Knock sensor is fitted to the cylinder block to detect engine knocking. This sensor contains a piezoelectric element which generates a voltage when it becomes deformed, which occurs when the cylinder block vibrates due to knocking. If engine knocking occurs, ignition timing is retarded to suppress it.

DTC No.	DTC Detecting Condition	Trouble Area
P0325	No knock sensor 1 signal to ECM with engine speed 1,200 rpm or more.	<ul style="list-style-type: none"> ● Open or short in knock sensor1 circuit ● Knock sensor 1 (looseness) ● ECM

If the ECM detects the above diagnosis conditions, it operates the fail safe function in which the corrective retard angle value is set to the maximum value.

● Indicates the diagnostic trouble code, diagnostic trouble code set parameter and suspect area of the problem.

WIRING DIAGRAM

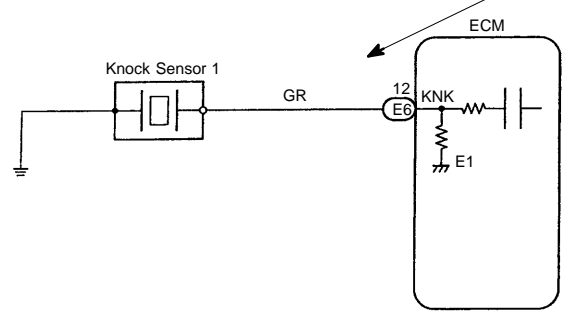

● Wiring Diagram
This shows a wiring diagram of the circuit. Use the diagram together with ELECTRICAL WIRING DIAGRAM to thoroughly understand the circuit.
Wiring colors are indicated by an alphabetical code.
B = Black, L = Blue, R = Red, BR = Brown, LG = Light Green, V = Violet, G = Green, O = Orange, W = White, GR = Gray, P = Pink, Y = Yellow
The first letter indicates the basic wire color and the second letter indicates the color of the stripe.

- Indicates the position of the ignition switch during the check.

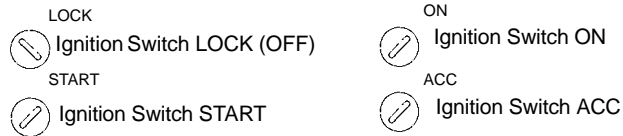

- Inspection Procedure

Use the inspection procedure to determine if the circuit is normal or abnormal, and, if it is abnormal, use it to determine whether the problem is located in the sensors, actuators, wire harness or ECU.

INSPECTION PROCEDURE

1 Check continuity between terminal KNK of ECM connector and body ground.

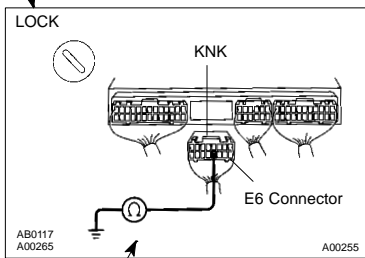

PREPARATION:

- (a) Remove the glove compartment.
- (b) Disconnect the E6 connector of ECM.

CHECK:

Measure resistance between terminal KNK of ECM connector and body ground.

OK:

Resistance: 1 MΩ or higher

OK → Go to step 3.

NG

2 Check knock sensor (See page SF-67).

OK → Replace knock sensor.

- Indicates the place to check the voltage or resistance.
- Indicates the connector position to checked, from the front or back side.

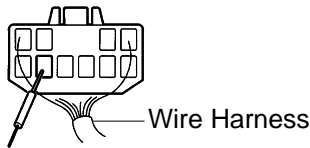

Check from the connector back side. (with harness)



Check from the connector front side. (without harness)
In this case, care must be taken not to bend the terminals.

- Indicates the condition of the connector of ECU during the check.

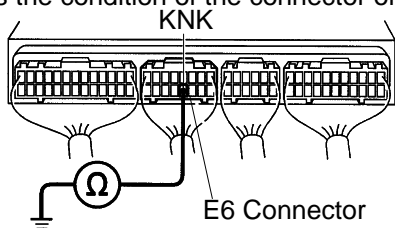

Connector being checked is connected.

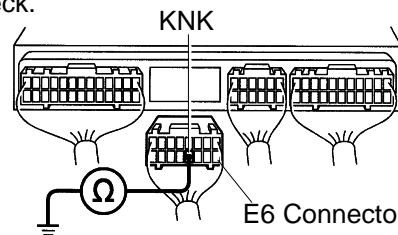

Connector being checked is disconnected.

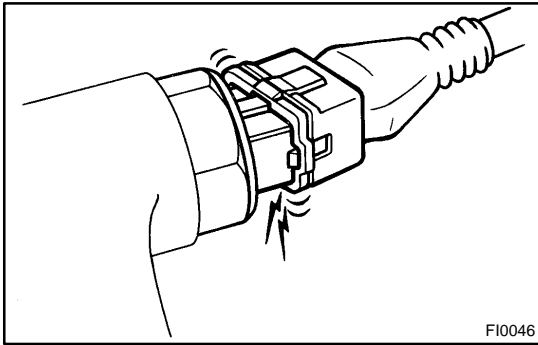

F10046

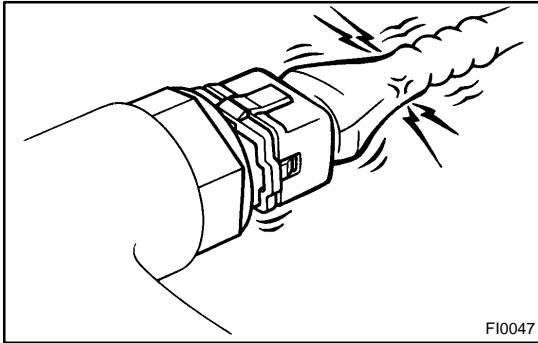

F10047

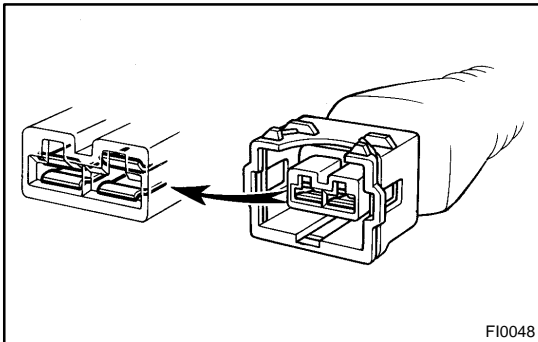

F10048

HOW TO USE THE DIAGNOSTIC CHART AND INSPECTION PROCEDURE

1. CONNECTOR CONNECTION AND TERMINAL INSPECTION

- For troubleshooting, diagnostic trouble code charts or problem symptom charts are provided for each circuit with detailed inspection procedures on the following pages.
- When all the component parts, wire harnesses and connectors of each circuit except the ECU are found to be normal in troubleshooting, then it is determined that the problem is in the ECU. Accordingly, if diagnosis is performed without the problem symptoms occurring, refer to step 8 to replace the ECU, even if the problem is not in the ECU. So always confirm that the problem symptoms are occurring, or proceed with inspection while using the symptom simulation method.
- The instructions "Check wire harness and connector" and "Check and replace ECU" which appear in the inspection procedure, are common and applicable to all diagnostic trouble codes. Follow the procedure outlined below whenever these instructions appear.

OPEN CIRCUIT:

This could be due to a disconnected wire harness, faulty contact in the connector, a connector terminal pulled out, etc.

HINT:

- It is rarely the case that a wire is broken in the middle of it. Most cases occur at the connector. In particular, carefully check the connectors of sensors and actuators.
- Faulty contact could be due to rusting of the connector terminals, to foreign materials entering terminals or a drop in the contact pressure between the male and female terminals of the connector. Simply disconnecting and reconnecting the connectors once changes the condition of the connection and may result in a return to normal operation. Therefore, in troubleshooting, if no abnormality is found in the wire harness and connector check, but the problem disappears after the check, then the cause is considered to be in the wire harness or connectors.

SHORT CIRCUIT:

This could be due to a short circuit between the wire harness and the body ground or to a short inside the switch etc.

HINT:

When there is a short between the wire harness and body ground, check thoroughly whether the wire harness is caught in the body or is clamped properly.

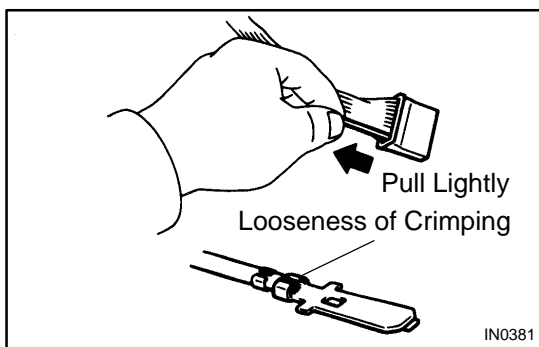
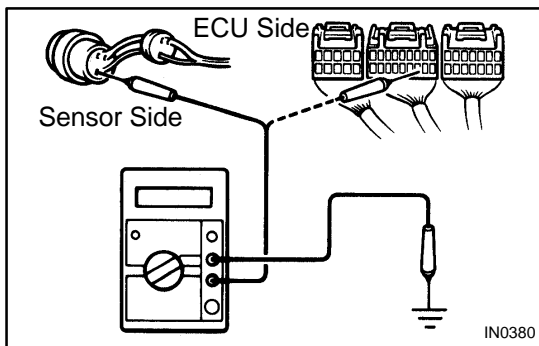
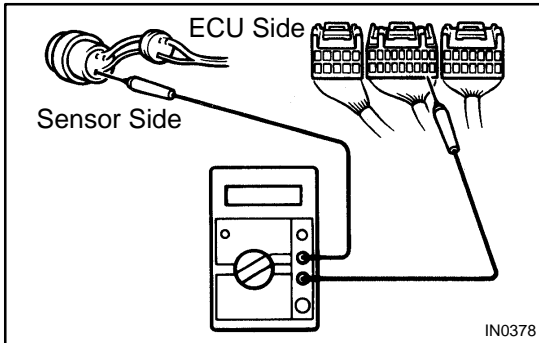
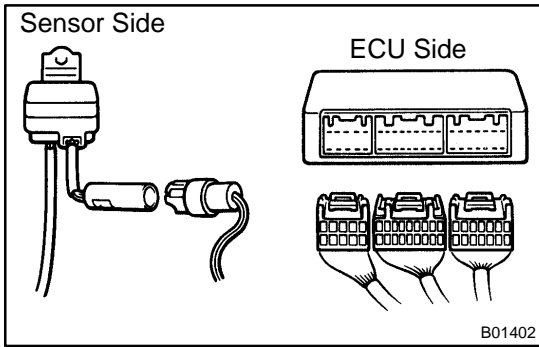

2. CONTINUITY CHECK (OPEN CIRCUIT CHECK)

- (a) Disconnect the connectors at both ECU and sensor sides.
- (b) Measure the resistance between the applicable terminals of the connectors.

Resistance: 1 Ω or less

HINT:

- Measure the resistance while lightly shaking the wire harness vertically and horizontally.
- When tester probes are inserted into a connector, insert the probes from the back. For waterproof connectors in which the probes cannot be inserted from the back, be careful not to bend the terminals when inserting the tester probes.

3. RESISTANCE CHECK (SHORT CIRCUIT CHECK)

- (a) Disconnect the connectors at both ends.
- (b) Measure the resistance between the applicable terminals of the connectors and body ground. Be sure to carry out this check on the connectors on both ends.

Resistance: 1 MΩ or higher

HINT:

Measure the resistance while lightly shaking the wire harness vertically and horizontally.

4. VISUAL CHECK AND CONTACT PRESSURE CHECK

- (a) Disconnect the connectors at both ends.
- (b) Check for rust or foreign material, etc. in the terminals of the connectors.
- (c) Check crimped portions for looseness or damage and check if the terminals are secured in lock portion.

HINT:

The terminals should not come out when pulled lightly.

- (d) Prepare a test male terminal and insert it in the female terminal, then pull it out.

NOTICE:

When testing a gold-plated female terminal, always use a gold-plated male terminal.

HINT:

When the test terminal is pulled out more easily than others, there may be poor contact in that section.

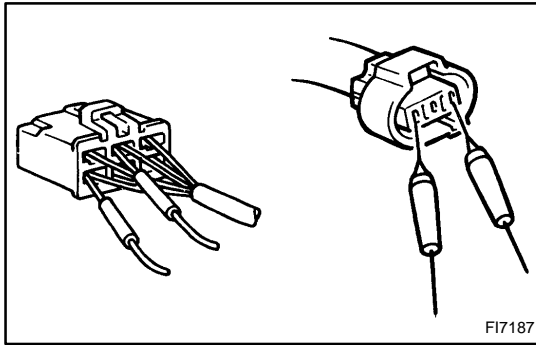

5. CONNECTOR HANDLING

When inserting tester probes into a connector, insert them from the rear of the connector. When necessary, use mini test leads. For water resistant connectors which cannot be accessed from behind, take good care not to deform the connector terminals.

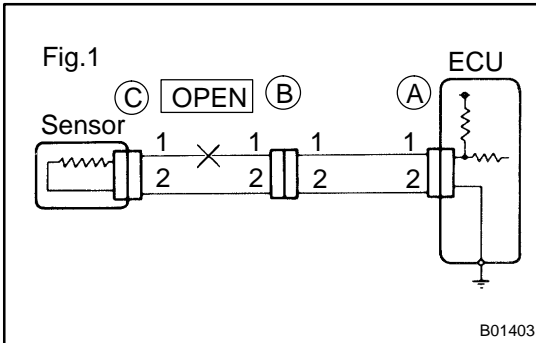

6. CHECK OPEN CIRCUIT

For the open circuit in the wire harness in Fig.1, perform "(a) Continuity Check" or "(b) Voltage Check" to locate the section.

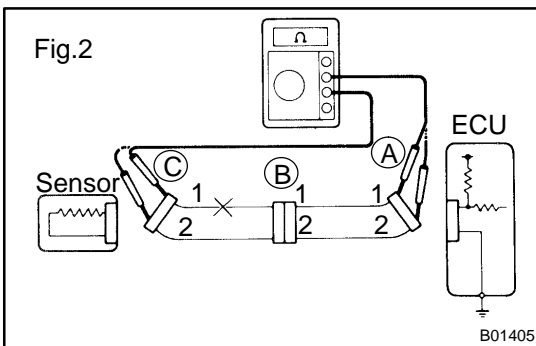

- (a) Check the continuity.
 - (1) Disconnect connectors "A" and "C" and measure the resistance between them.
 In the case of Fig.2,
 Between terminal 1 of connector "A" and terminal 1 of connector "C" → No continuity (open)
 Between terminal 2 of connector "A" and terminal 2 of connector "C" → Continuity
 Therefore, it is found out that there is an open circuit between terminal 1 of connector "A" and terminal 1 of connector "C".

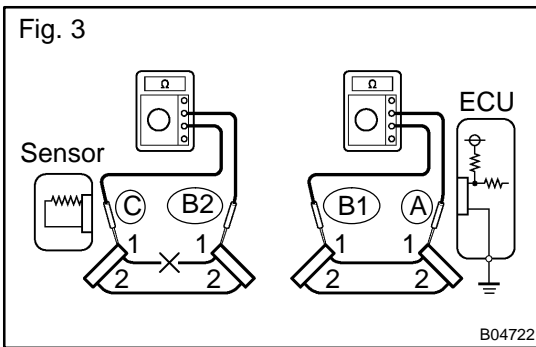

- (2) Disconnect connector "B" and measure the resistance between the connectors.
 In the case of Fig.3,
 Between terminal 1 of connector "A" and terminal 1 of connector "B1" → Continuity
 Between terminal 1 of connector "B2" and terminal 1 of connector "C" → No continuity (open)
 Therefore, it is found out that there is an open circuit between terminal 1 of connector "B2" and terminal 1 of connector "C".

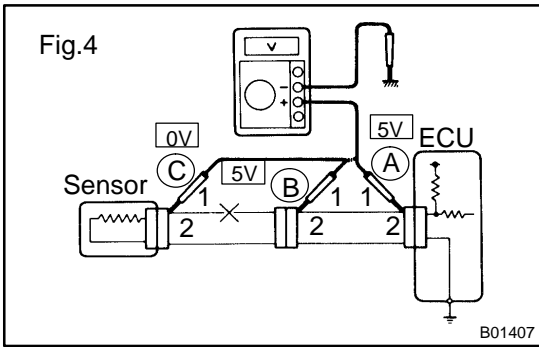

(b) Check the voltage.
 In a circuit in which voltage is applied (to the ECU connector terminal), an open circuit can be checked for by conducting a voltage check.

- (1) As shown in Fig.4, with each connector still connected, measure the voltage between body ground and terminal 1 of connector "A" at the ECU 5V output terminal, terminal 1 of connector "B", and terminal 1 of connector "C", in that order.

If the results are:

5V: Between Terminal 1 of connector "A" and Body Ground

5V: Between Terminal 1 of connector "B" and Body Ground

0V: Between Terminal 1 of connector "C" and Body Ground

Then it is found out that there is an open circuit in the wire harness between terminal 1 of "B" and terminal 1 of "C".

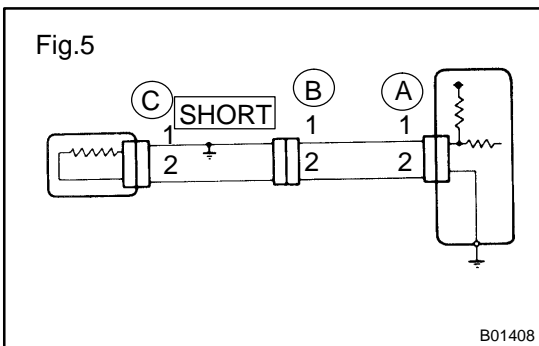

7. CHECK SHORT CIRCUIT

If the wire harness is ground shorted as in Fig.5, locate the section by conducting a "continuity check with ground".

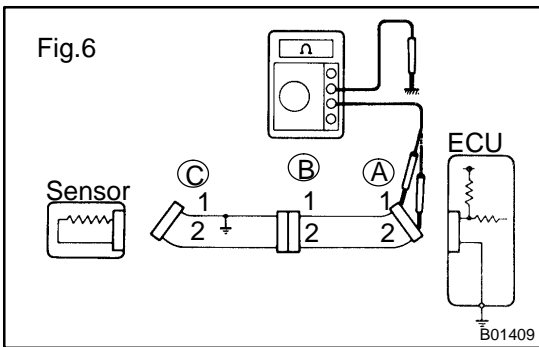

- (a) Check the continuity with ground.

- (1) Disconnect connectors "A" and "C" and measure the resistance between terminal 1 and 2 of connector "A" and body ground.

In the case of Fig.6,

Between terminal 1 of connector "A" and body ground → Continuity (short)

Between terminal 2 of connector "A" and body ground → No continuity

Therefore, it is found out that there is a short circuit between terminal 1 of connector "A" and terminal 1 of connector "C".

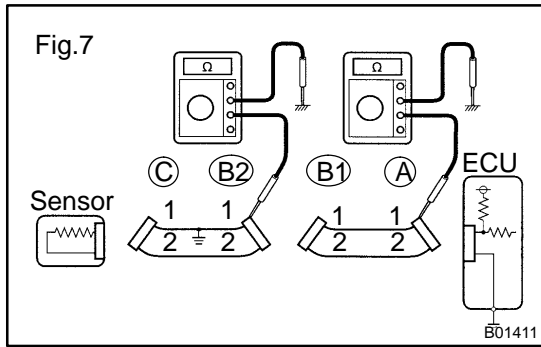

- (2) Disconnect connector "B" and measure the resistance between terminal 1 of connector "A" and body ground, and terminal 1 of connector "B2" and body ground.
 Between terminal 1 of connector "A" and body ground → No continuity
 Between terminal 1 of connector "B2" and body ground → Continuity (short)
 Therefore, it is found out that there is a short circuit between terminal 1 of connector "B2" and terminal 1 of connector "C".

8. CHECK AND REPLACE ECU

First check the ECU ground circuit. If it is faulty, repair it. If it is normal, the ECU could be faulty, so replace the ECU with a known good one and check if the symptoms appear.

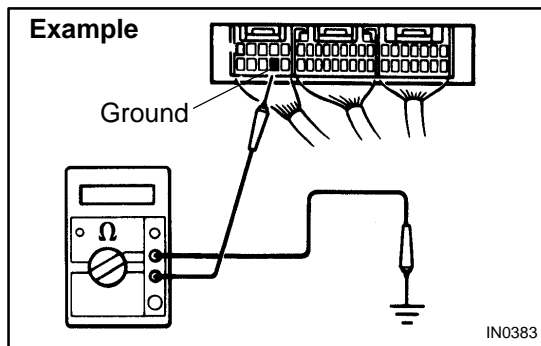

- (a) Measure the resistance between the ECU ground terminal and the body ground.
Resistance: 1 Ω or less

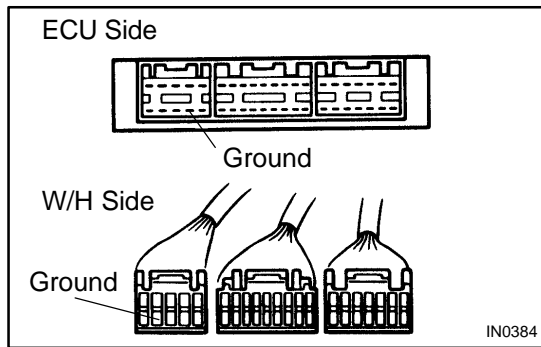

- (b) Disconnect the ECU connector, check the ground terminals on the ECU side and the wire harness side for bend and check the contact pressure.

TERMS

ABBREVIATIONS USED IN THIS MANUAL

IN04I-01

Abbreviations	Meaning
ABS	Anti-Lock Brake System
ALR	Automatic Locking Retractor
APPROX.	Approximately
A/T, ATM	Automatic Transmission
ATF	Automatic Transmission Fluid
BTDC	Before Top Dead Center
CB	Circuit Breaker
CD	Compact Disc
CRS	Child Restraint System
DOHC	Double Over Head Cam
DP	Dash Pot
ECU	Electronic Control Unit
ELR	Emergency Locking Retractor
ESA	Electronic Spark Advance
EX	Exhaust (Manifold, Valve)
FIPG	Formed in Place Gasket
FL	Fusible Link
Fr	Front
H-Fuse	High Current Fuse
IG	Ignition
IN	Intake (Manifold, Valve)
J/B	Junction Block
LED	Light Emitting Diode
LH	Left-Hand
LLC	Long Life Coolant (Year Around Coolant)
LSD	Limited Slip Differential
Max.	Maximum
Min.	Minimum
MP	Multipurpose
M/T	Manual Transmission
O/D, OD	Overdrive
O/S	Oversize
P&BV	Proportioning and Bypass Valve
PCV	Positive Crankcase Ventilation
PPS	Progressive Power Steering
PS	Power Steering
RH	Right-Hand
Rr	Rear
SRS	Supplemental Restraint System
SSM	Special Service Materials
SST	Special Service Tools
STD	Standard

1997 SUPRA (RM502U)

SW	Switch
TDC	Top Dead center
TEMP.	Temperature
TRAC	Traction Control System
U/S	Undersize
VCV	Vacuum Control Valve
VSV	Vacuum Switching Valve
VTV	Vacuum Transmitting Valve
w/	With
w/o	Without

GLOSSARY OF SAE AND TOYOTA TERMS

This glossary lists all SAE-J1930 terms and abbreviations used in this manual in compliance with SAE recommendations, as well as their Toyota equivalents.

SAE ABBREVIATIONS	SAE TERMS	TOYOTA TERMS ()--ABBREVIATIONS
A/C	Air Conditioning	Air Conditioner
ACL	Air Cleaner	Air Cleaner
AIR	Secondary Air Injection	Air Injection (AI)
AP	Accelerator Pedal	-
B+	Battery Positive Voltage	+B, Battery Voltage
BARO	Barometric Pressure	-
CAC	Charge Air Cooler	Intercooler
CARB	Carburetor	Carburetor
CFI	Continuous Fuel Injection	-
CKP	Crankshaft Position	Crank Angle
CL	Closed Loop	Closed Loop
CMP	Camshaft Position	Cam Angle
CPP	Clutch Pedal Position	-
CTOX	Continuous Trap Oxidizer	-
CTP	Closed Throttle Position	-
DFI	Direct Fuel Injection (Diesel)	Direct Injection (DI)
DI	Distributor Ignition	-
DLC1 DLC2 DLC3	Data Link Connector 1 Data Link Connector 2 Data Link Connector 3	1: Check Connector 2: Total Diagnosis Comunication Link (TDCL) 3: OBD II Diagnostic Connector
DTC	Diagnostic Trouble Code	Diagnostic Code
DTM	Diagnostic Test Mode	-
ECL	Engine Control Level	-
ECM	Engine Control Module	Engine ECU (Electronic Control Unit)
ECT	Engine Coolant Temperature	Coolant Temperature, Water Temperature (THW)
EEPROM	Electrically Erasable Programmable Read Only Memory	Electrically Erasable Programmable Read Only Memory (EEPROM), Erasable Programmable Read Only Memory (EPROM)
EFE	Early Fuel Evaporation	Cold Mixture Heater (CMH), Heat Control Valve (HCV)
EGR	Exhaust Gas Recirculation	Exhaust Gas Recirculation (EGR)
EI	Electronic Ignition	Distributorless Ignition (DI)
EM	Engine Modification	Engine Modification (EM)
EPROM	Erasable Programmable Read Only Memory	Programmable Read Only Memory (PROM)
EVAP	Evaporative Emission	Evaporative Emission Control (EVAP)
FC	Fan Control	-
FEEPROM	Flash Electrically Erasable Programmable Read Only Memory	-
FEPROM	Flash Erasable Programmable Read Only Memory	-
FF	Flexible Fuel	-
FP	Fuel Pump	Fuel Pump
GEN	Generator	Alternator
GND	Ground	Ground (GND)

HO2S	Heated Oxygen Sensor	Heated Oxygen Sensor (HO2S)
IAC	Idle Air Control	Idle Speed Control (ISC)
IAT	Intake Air Temperature	Intake or Inlet Air Temperature
ICM	Ignition Control Module	-
IFI	Indirect Fuel Injection	Indirect Injection
IFS	Inertia Fuel-Shutoff	-
ISC	Idle Speed Control	-
KS	Knock Sensor	Knock Sensor
MAF	Mass Air Flow	Air Flow Meter
MAP	Manifold Absolute Pressure	Manifold Pressure Intake Vacuum
MC	Mixture Control	Electric Bleed Air Control Valve (EBCV) Mixture Control Valve (MCV) Electric Air Control Valve (EACV)
MDP	Manifold Differential Pressure	-
MFI	Multiport Fuel Injection	Electronic Fuel Injection (EFI)
MIL	Malfunction Indicator Lamp	Check Engine Light
MST	Manifold Surface Temperature	-
MVZ	Manifold Vacuum Zone	-
NVRAM	Non-Volatile Random Access Memory	-
O2S	Oxygen Sensor	Oxygen Sensor, O ₂ Sensor (O ₂ S)
OBD	On-Board Diagnostic	On-Board Diagnostic (OBD)
OC	Oxidation Catalytic Converter	Oxidation Catalyst Converter (OC), CCo
OP	Open Loop	Open Loop
PAIR	Pulsed Secondary Air Injection	Air Suction (AS)
PCM	Powertrain Control Module	-
PNP	Park/Neutral Position	-
PROM	Programmable Read Only Memory	-
PSP	Power Steering Pressure	-
PTOX	Periodic Trap Oxidizer	Diesel Particulate Filter (DPF) Diesel Particulate Trap (DPT)
RAM	Random Access Memory	Random Access Memory (RAM)
RM	Relay Module	-
ROM	Read Only Memory	Read Only Memory (ROM)
RPM	Engine Speed	Engine Speed
SC	Supercharger	Supercharger
SCB	Supercharger Bypass	-
SFI	Sequential Multiport Fuel Injection	Electronic Fuel Injection (EFI), Sequential Injection
SPL	Smoke Puff Limiter	-
SRI	Service Reminder Indicator	-
SRT	System Readiness Test	-
ST	Scan Tool	-
TB	Throttle Body	Throttle Body
TBI	Throttle Body Fuel Injection	Single Point Injection Central Fuel Injection (Ci)
TC	Turbocharger	Turbocharger
TCC	Torque Converter Clutch	Torque Converter

INTRODUCTION - TERMS

TCM	Transmission Control Module	Transmission ECU (Electronic Control Unit)
TP	Throttle Position	Throttle Position
TR	Transmission Range	-
TVV	Thermal Vacuum Valve	Bimetallic Vacuum Switching Valve (BVSV) Thermostatic Vacuum Switching Valve (TVSV)
TWC	Three-Way Catalytic Converter	Three-Way Catalytic (TWC) CC _{RO}
TWC+OC	Three-Way + Oxidation Catalytic Converter	CC _R + CC _o
VAF	Volume Air Flow	Air Flow Meter
VR	Voltage Regulator	Voltage Regulator
VSS	Vehicle Speed Sensor	Vehicle Speed Sensor (Reed Switch Type)
WOT	Wide Open Throttle	Full Throttle
WU-OC	Warm Up Oxidation Catalytic Converter	-
WU-TWC	Warm Up Three-Way Catalytic Converter	Manifold Converter
3GR	Third Gear	-
4GR	Fourth Gear	-