

2JZ-GE ENGINE TROUBLESHOOTING

HOW TO PROCEED WITH TROUBLESHOOTING

Troubleshoot in accordance with the procedure on the following pages.

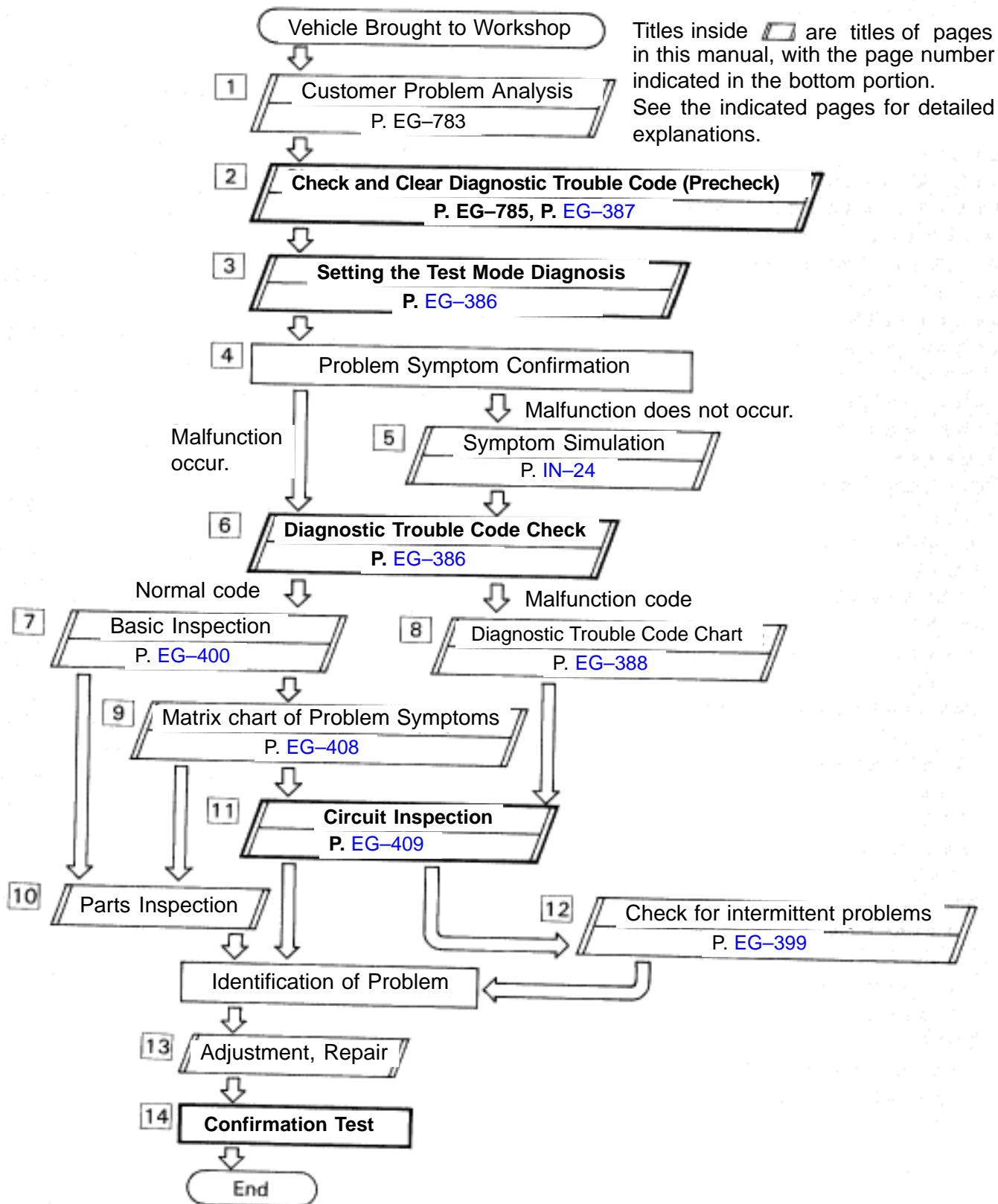

Step [2], [3], [6], [11], [14]: Diagnostic steps permitting the use of the TOYOTA hand-held tester or TOYOTA break-out-box.

CUSTOMER PROBLEM ANALYSIS CHECK SHEET

ENGINE CONTROL System Check Sheet

Inspector's
Name _____

Customer's Name	Registration No.	
	Registration Year	/ /
	Frame No.	
Date Vehicle Brought In	Odometer Reading	km Miles

Date Problem Occurred	
Frequency Problem Occurs	<input type="checkbox"/> Constant <input type="checkbox"/> Sometimes (times per day/month) <input type="checkbox"/> Once only <input type="checkbox"/> Other ()
Conditions When Problem Occurs	Weather <input type="checkbox"/> Fine <input type="checkbox"/> Cloudy <input type="checkbox"/> Rainy <input type="checkbox"/> Snowy <input type="checkbox"/> Various/Other ()
	Outdoor Temperature <input type="checkbox"/> Hot <input type="checkbox"/> Warm <input type="checkbox"/> Cool <input type="checkbox"/> Cold (Approx. °F(°C))
	Place <input type="checkbox"/> Highway <input type="checkbox"/> Suburbs <input type="checkbox"/> Inner City <input type="checkbox"/> Hill (<input type="checkbox"/> Up, <input type="checkbox"/> Down) <input type="checkbox"/> Rough road <input type="checkbox"/> Other ()
	Engine Temp. <input type="checkbox"/> Cold <input type="checkbox"/> Warming up <input type="checkbox"/> After warming up <input type="checkbox"/> Any temp. <input type="checkbox"/> Other ()
	Engine Operation <input type="checkbox"/> Starting <input type="checkbox"/> Just after starting <input type="checkbox"/> Idling <input type="checkbox"/> Racing without load <input type="checkbox"/> Driving (<input type="checkbox"/> Constant speed <input type="checkbox"/> Acceleration <input type="checkbox"/> Deceleration <input type="checkbox"/> Other ()

Problem Symptoms	<input type="checkbox"/> Engine does not Start	<input type="checkbox"/> Engine does not crank <input type="checkbox"/> No initial combustion <input type="checkbox"/> No complete combustion
	<input type="checkbox"/> Difficult to Start	<input type="checkbox"/> Engine cranks slowly <input type="checkbox"/> Other ()
	<input type="checkbox"/> Poor Idling	<input type="checkbox"/> Incorrect first idle <input type="checkbox"/> Idling rpm is abnormal (<input type="checkbox"/> High <input type="checkbox"/> Low (rpm)) <input type="checkbox"/> Rough idling <input type="checkbox"/> Other ()
	<input type="checkbox"/> Poor Driveability	<input type="checkbox"/> Hesitation <input type="checkbox"/> Back fire <input type="checkbox"/> Muffler explosion (after fire) <input type="checkbox"/> Surging <input type="checkbox"/> Knocking <input type="checkbox"/> Other ()
	<input type="checkbox"/> Engine Stall	<input type="checkbox"/> Engine stall soon after starting <input type="checkbox"/> After accelerator pedal depressed <input type="checkbox"/> After accelerator pedal released <input type="checkbox"/> During A/C operation <input type="checkbox"/> When N to D shift <input type="checkbox"/> Other ()
	<input type="checkbox"/> Others	

Condition of Malfunction Indicator Lamp	<input type="checkbox"/> Remains on <input type="checkbox"/> Sometimes lights up <input type="checkbox"/> Does not light up
Diagnostic Trouble Code Inspection	Normal Mode (Precheck) <input type="checkbox"/> Normal code <input type="checkbox"/> Malfunction code (code)
	Test Mode <input type="checkbox"/> Normal code <input type="checkbox"/> Malfunction code (code)



DIAGNOSIS SYSTEM DESCRIPTION

The ECM contains a built-in self-diagnosis system by which troubles with the engine signal network are detected and a Malfunction Indicator Lamp on the instrument panel lights up.

By analyzing various signals as shown in a later table (See page [EG-388](#)) the Engine Control Module (ECM) detects system malfunctions relating to the sensors or actuators.

In the normal mode, the self-diagnosis system monitors 18 (California specification vehicles) or 17 (except for California and Canadian specification) items, indicated by code No. as shown in [EG-388](#). A malfunction indicator lamp informs the driver that a malfunction has been detected. The lamp goes off automatically when the malfunction has been repaired, but the diagnostic trouble code(s) remains stored in the ECM memory (except for code Nos. 16 and 53). The ECM stores the code(s) until it is cleared by removing the EFI No. 1 fuse with the ignition switch OFF.

The diagnostic trouble code can be read by the number of blinks of the malfunction indicator lamp when TE1 and E1 terminals on the data link connector 1 or 2 are connected. When 2 or more codes are indicated, the lowest number (code) will appear first.

In the test mode, 12 (California specification vehicles) or 11 (except for California and Canadian specification vehicles) items, indicated by code No. as shown in [EG-388](#) are monitored. If a malfunction is detected in any one of the systems indicated by code Nos. 13, 21, 22, 24, 25, 26, 27, 28, 35, 41, 71 and 78 (California specification vehicles) or 13, 21, 22, 24, 25, 28, 35, 41, 71 and 78 (except for California and Canadian specification vehicles) the ECM lights the malfunction indicator lamp to warn the technician that a malfunction has been detected. In this case, TE2 and E1 terminals on the data link connector 2 should be connected as shown later. (See page [EG-386](#)).

In the test mode, even if the malfunction is corrected, the malfunction code is stored in the ECM memory even when the ignition switch OFF (except code Nos. 43 and 51). This also applies in the normal mode. The diagnostic trouble mode (normal or test) and the output of the malfunction indicator lamp can be selected by connecting the TE1, TE2 and E1 terminals on the data link connector 2, as shown later.

A test mode function has been added to the functions of the self-diagnosis system of the normal mode for the purpose of detecting malfunctions such as poor contact, which are difficult to detect in the normal mode. This function fills up the self-diagnosis system. The test mode can be implemented by the technician following the appropriate procedures of check terminal connection and operation described later. (See page [EG-386](#))

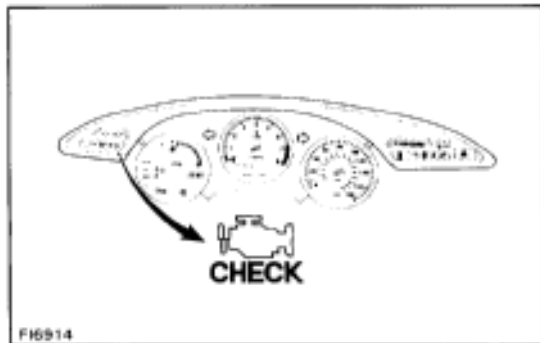

Diagnosis Inspection (Normal Mode) MALFUNCTION INDICATOR LAMP CHECK

1. The Malfunction Indicator Lamp will come on when the ignition switch is turned ON and the engine is not running.
HINT: If the malfunction indicator lamp does not light up, proceed to troubleshooting of the telltale light RH (See page [BE-48](#)).
2. When the engine is started, the malfunction indicator lamp should go off.
If the light remains on, the diagnosis system has detected a malfunction or abnormality in the system.

DIAGNOSTIC TROUBLE CODE CHECK

1. Turn ignition switch ON.
2. Using SST, connect terminals between TE1 and E1 of data link connector 1 or 2.
SST 09843-18020

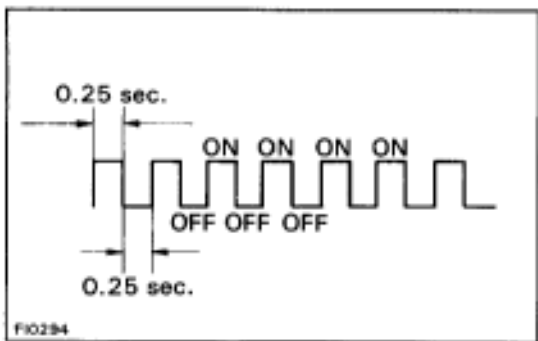
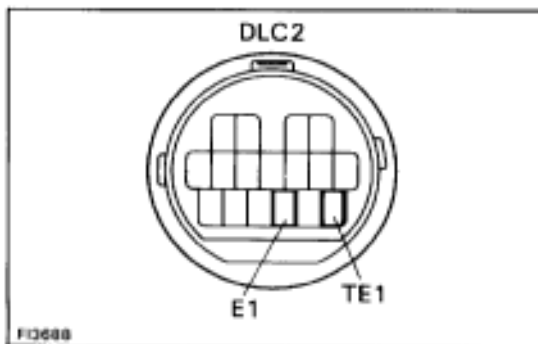
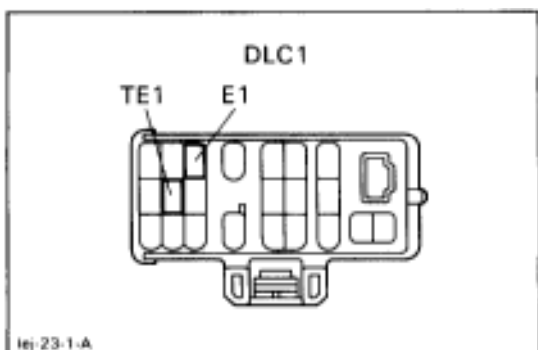

3. Read the diagnostic trouble code from malfunction indicator lamp.
HINT: If a diagnostic trouble code is not output, check the TE1 terminal circuit (See page [EG-484](#)).

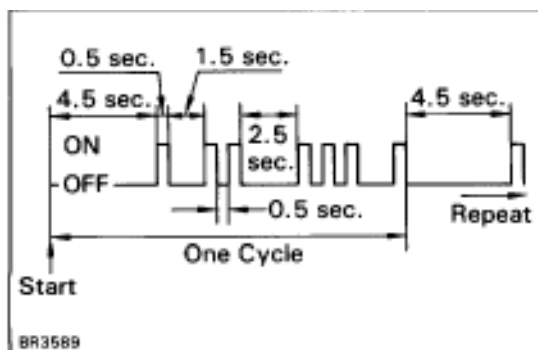

4. As an example, the blinking patterns for codes; normal, 12 and 31 are as shown on the illustration.
4. Check the details of the malfunction using the diagnostic trouble code table on page [EG-388](#).
5. After completing the check, disconnect terminals TE1 and E1, and turn off the display.
HINT: In the event of 2 or more malfunction codes, indication will begin from the smaller numbered code and continue in order to the larger.

Diagnosis Inspection (Test Mode)

Compared to the normal mode, the test mode has an increased sensing ability to detect malfunctions.

It can also detect malfunctions in the starter signal circuit, the IDL contact signal of the throttle position sensor, air conditioning signal and park/neutral position switch signal.

Furthermore, the same diagnostic items which are detected in the normal mode can also be detected in the test mode.

DIAGNOSTIC TROUBLE CODE CHECK

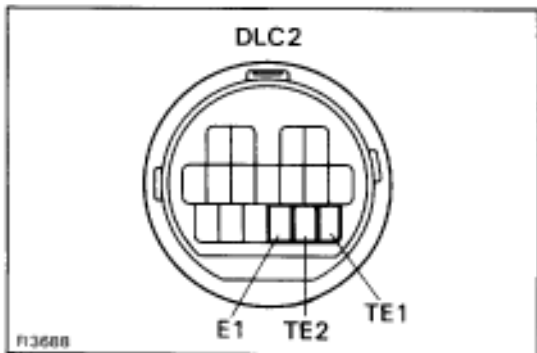
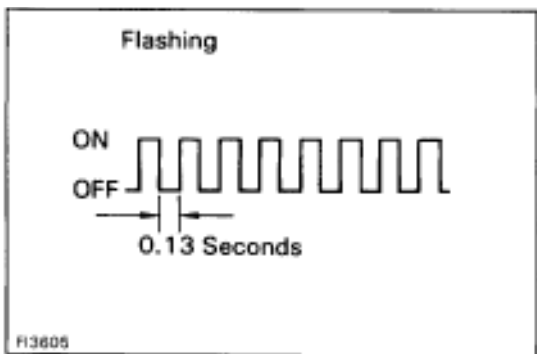
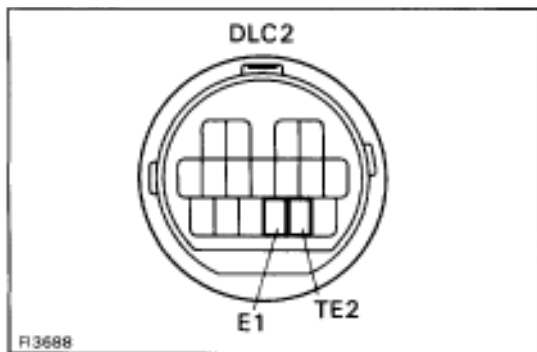

1. Initial conditions.
 - (a) Battery voltage 11 V or more
 - (b) Throttle valve fully closed
 - (c) Transmission in neutral position
 - (d) Air conditioning switched OFF
2. Turn ignition switch OFF
3. Using SST, connect terminals TE2 and E1 of the data link connector 2.
SST 09843-18020
4. Turn ignition switch ON.
HINT:
 - To confirm that the test mode is operating, check that the malfunction indicator lamp flashes when the ignition switch is turned to ON.
 - If the malfunction indicator lamp does not flash, proceed to troubleshooting of the TE2 terminal circuit on page [EG-484](#).
5. Start the engine.
6. Simulate the conditions of the malfunction described by the customer.
7. After the road test, using SST, connect terminals TE1 and E1 of the data link connector 2.
SST 09843-18020
8. Read the diagnostic trouble code on malfunction indicator lamp on the telltale light RH (See page [EG-385](#)).
9. After completing the check, disconnect terminals TE1, TE2 and E1, and turn off the display.
HINT:
 - The test mode will not start if terminals TE2 and E1 are connected after the ignition switch is turned ON.
 - When the engine is not cranked, diagnostic trouble codes "43" (Starter signal) output, but this is not abnormal.
 - When the automatic transmission shift lever is in the "D", "2", "L" or "R" shift position, or when the air conditioning is on or when the accelerator pedal is depressed, code "51" (Switch condition signal) is output, but this is not abnormal.

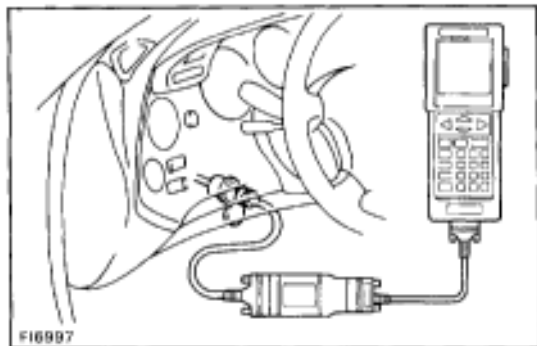

DIAGNOSTIC TROUBLE CODE CHECK USING TOYOTA HAND-HELD TESTER

1. Hook up the TOYOTA hand-held tester to the DLC2.
2. Read the diagnostic trouble codes by following the prompts on the tester screen.

Please refer to the TOYOTA hand-held tester operation's manual for further details.

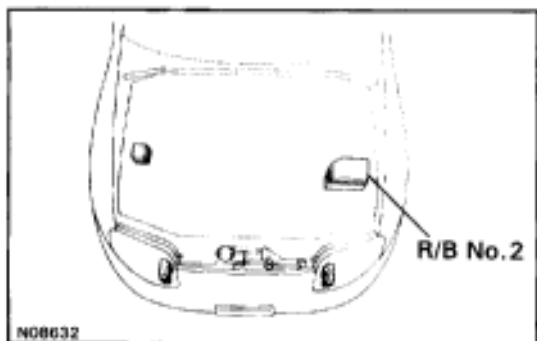

DIAGNOSTIC TROUBLE CODE CLEARANCE

1. After repair of the trouble areas, the diagnostic trouble code retained in the ECM memory must be cleared out by removing the EFI No.1 fuse (30A) from R/B No.2 for 10 seconds or more, with the ignition switch OFF.

HINT:

- Cancellation can also be done by removing the negative (-) terminal cable from the battery, but in this case, other memory systems (clock, etc.) will also be cancelled out.
- If it is necessary to work on engine components requiring removal of the negative (-) terminal cable from the battery, a check must first be made to see if a diagnostic trouble code has been recorded.

2. After cancellation, road test the vehicle to check that a normal code is now read on the malfunction indicator lamp. If the same diagnostic trouble code appears, it indicates that the trouble area has not been repaired thoroughly.

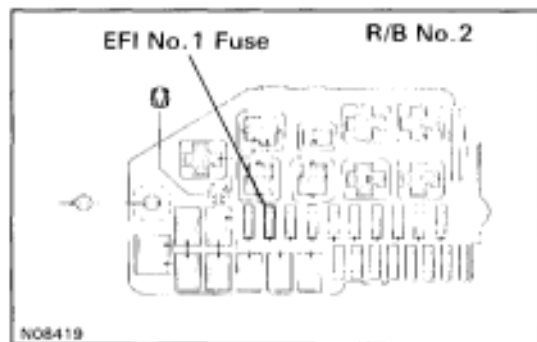

ECM DATA MONITOR USING TOYOTA HAND-HELD TESTER

1. Hook up the TOYOTA hand-held tester to the DLC2.
2. Monitor the ECM data by following the prompts on the tester screen.

HINT: TOYOTA hand-held tester has a "Snapshot" function which records the monitored data.

Please refer to TOYOTA hand-held tester operator's manual for further details.

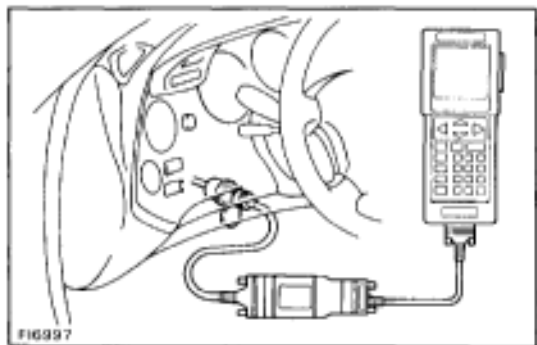

ECM TERMINAL VALUES MEASUREMENT USING TOYOTA BREAK-OUT-BOX AND TOYOTA HAND-HELD TESTER

1. Hook up the TOYOTA break-out-box and TOYOTA handheld tester to the vehicle.
2. Read the ECM input/output values by following the prompts on the tester screen.





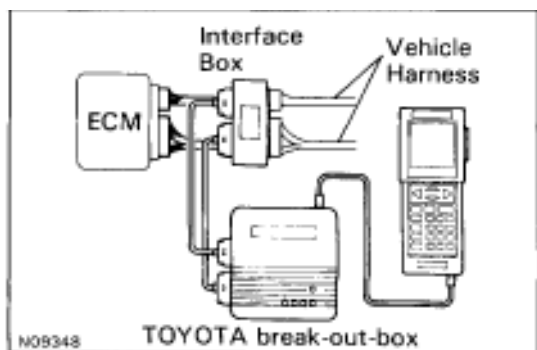

HINT: TOYOTA hand-held tester has a "Snapshot" function. This records the measured values and is effective in the diagnosis of intermittent problems.

Please refer to TOYOTA hand-held tester/TOYOTA break-out box operator's manual for further details.



DIAGNOSTIC TROUBLE CODE CHART

HINT: Parameters listed in the chart may not be exactly the same as your reading due to type of the instruments or other factors.



DTC No.	Number of MIL Blinks	Circuit	Diagnostic Trouble Code Detecting Condition
-	 BE3931	Normal	No code is recorded.
12	 BE3931	G, NE Signal (No.1)	No NE or G1 and G2 signal to ECM for 2 sec. or more after cranking
			Open in "G ⊕" circuit
13	 BE3931	G, NE Signal (No.2)	No NE signal to ECM for 0.1 sec. or more at 1,000 rpm or more
			NE signal does not pulse 12 times to ECM during the interval between G1 and G2 pulses
14	 BE3931	Ignition Signal	No IGF signal to ECM for 6 consecutive IGT signals
16	 BE3931	A/T Control Signal	Fault in communications between the engine CPU and A/T CPU in the ECM
21	 BE3932	(Main heated *3) Oxygen Sensor Signal (Fr)	(1)*3 Open or short in heater circuit of main heated oxygen sensor (Fr) for 0.5 sec. or more
			(2) (Main heated*3) oxygen sensor (Fr) signal voltage is reduced to between 0.35 V and 0.70 V for 90 sec. under conditions (a) - (d): (2 trip detection logic)*4 (a) Engine coolant temp.: Between 80°C (176°F) and 95°C (203°F) (b) Engine speed: 1,500 rpm or more (c) Load driving (example A/T in in Overdrive, (5th for M/T), A/C ON, Flat road, 80 km/H (50 mph)) (d) (Main heated*3) oxygen sensor (Fr) signal voltage: Alternating above and below 0.45 V

*3, 4: See page [EG-396](#), 397.

If a malfunction code is displayed during the diagnostic trouble code check in test mode, check the circuit for that code listed in the table below (Proceed to the page given for that circuit).

Trouble Area	Malfunction Indicator Lamp*1		Memory*2	See page
	Normal Mode	Test Mode		
_____	-	-	_____	_____
<ul style="list-style-type: none"> • Open or short in NE, G circuit • Distributor • Open or short in STA circuit • ECM 	ON	N.A.	○	EG-409
<ul style="list-style-type: none"> • Open or short in NE circuit • Distributor • ECM 	ON	N.A.	○	EG-412
<ul style="list-style-type: none"> • Open or short in NE circuit • Distributor • ECM 	N.A.	ON		
<ul style="list-style-type: none"> • Open or short in IGT or IGT circuit from igniter to ECM • Igniter • ECM 	ON	N.A.	○	EG-413
<ul style="list-style-type: none"> • ECM 	ON	N.A.	×	EG-418
<ul style="list-style-type: none"> • Open or short in heater circuit of main heated oxygen sensor (Fr) • Main heated oxygen sensor (Fr) heater • ECM 	ON	N.A.	○	EG-419
<ul style="list-style-type: none"> • (Main heated*3) oxygen sensor (Fr) circuit • (Main heated*3) oxygen sensor (Fr) 	ON	ON		



*1, 2, 3: See page [EG-396](#)

DTC No.	Number of MIL Blinks	Circuit	Diagnostic Trouble Code Detecting Condition
22	 BE3932	Engine Coolant Temp. Sensor Circuit	Open or short in engine coolant temp. sensor circuit for 0.5 sec. or more
24	 BE3932	Intake Air Temp. Sensor Signal	Open or short in intake air temp. sensor circuit for 0.5 sec. or more
25	 BE3932	Air-Fuel Ratio Lean Malfunction	<p>(1) (Main heated*³) oxygen sensor voltage is 0.45 V or less (lean) for 90 sec. under conditions (a) and (b): (2 trip detection logic)*⁴ (a) Engine speed: 1,500 rpm or more (b) Engine coolant temp.: 70°C (158°F) or more</p> <p>(2)*³ Difference of air-fuel ratio feedback compensation value between front (no.1 ~ 3 cylinders) and rear (No.4 ~ 6 cylinders) is more than 15 percentage for 20 sec. or more under conditions (a) and (b): (2 trip detection logic)*⁴ (a) Engine speed: 2,000 rpm or more (b) Engine coolant temp.: Between 60°C (140°F) and 95°C (203°F)</p> <p>(3)*³ Engine speed varies by more than 15 rpm over the preceding crank angle period during a period of 20 sec. or more under conditions (a) and (b): (2 trip detection logic)*⁴ (a) Engine speed: Idling (b) Engine coolant temp.: Between 60°C (140°F) and 95°C (203°F)</p>

*3, 4: See page [EG-396](#) 397.

Trouble Area	Malfunction Indicator Lamp*1		Memory*2	See page
	Normal Mode	Test Mode		
<ul style="list-style-type: none"> • Open or short in engine coolant temp. sensor circuit • Engine coolant temp. sensor • ECM 	ON	ON	○	EG-424
<ul style="list-style-type: none"> • Open or short in intake air temp. sensor circuit • Intake air temp. sensor • ECM 	ON	ON	○	EG-426
<ul style="list-style-type: none"> • Open or short in (main heated*3) oxygen sensor circuit • (Main heated*3) oxygen sensor • Ignition system • ECM 	ON	ON	○	EG-428
<ul style="list-style-type: none"> • Open or short in injector circuit • Fuel line pressure (injector leak, blockage) • Mechanical system malfunction (skipping teeth of timing belt) • Ignition system • Compression pressure (foreign object caught in valve) • Volume air flow meter (air intake) • ECM 				
<ul style="list-style-type: none"> • Open or short in injector circuit • Fuel line pressure (injector leak, blockage) • Mechanical system malfunction (skipping teeth of timing belt) • Ignition system • Compression pressure (foreign object caught in valve) • Volume air flow meter (air intake) • ECM 				









*1, 2, 3: See page [EG-396](#).

DTC No.	Number of MIL Blinks	Circuit	Diagnostic Trouble Code Detecting Condition
26	 <small>BE3932</small>	Air-Fuel Ratio Rich Malfunction	<p>(1) Difference of air-fuel ratio feedback compensation value between front (No.1 ~ 3 cylinders) and rear (No.4 ~ 6 cylinders) is more than 15 percentage for 20 sec. or more under conditions(a) and (b): (2 trip detection logic)*4 (a) Engine speed: 2,000 rpm or more (b) Engine coolant temp.: Between 60°C (140°F) and 95°C (203°F)</p> <p>(2) Engine speed varies by more than 15 rpm over the preceding crank angle period during a period of 20 sec. or more under conditions (a) and (b): (2 trip detection logic)*4 (a) Engine speed: 2,000 rpm or more (b) Engine coolant temp.: Between 60°C (140°F) and 95°C (203°F)</p>
27*3	 <small>BE3932</small>	Sub Heated Oxygen Sensor Signal	<p>(1) Open or short in heater circuit of sub heated oxygen sensor for 0.5 sec. or more</p> <p>(2) Main heated oxygen sensor signal is 0.45 V or more and sub oxygen sensor signal is 0.45 V or less under conditions (a) ~ (c): (2 trip detection logic)*4 (a) Engine coolant temp.: 80°C (176°F) or more (b) Engine speed: 1,500 rpm or more (c) Accel. pedal: Fully depressed for 2 sec. or more</p>
28	 <small>BE3932</small>	(Main heated*3) Oxygen Sensor Signal (Rr)	<p>(1)*3 Open or short in heater circuit of main heated oxygen sensor (Rr) for 0.5 sec. or more </p> <p>(2) (Main heated*3) oxygen sensor (Rr) signal voltage is reduced to between 0.35 V and 0.70 V for 90 sec. under conditions (a) ~ (d) (2 trip detection logic)*4 (a) Engine coolant temp.: Between 80°C (176°F) and 95°C (203°F) (b) Engine speed: 1,500 rpm or more. (c) Load driving (Example A/T in Overdrive (5th for M/T), A/C ON, Flat road, 80 km/h (50 mph)) (d) (Main heated*3) oxygen sensor (Rr) signal voltage: Alternating above and below 0.45 V</p>

*3, 4: See page EG-396, 397



Trouble Area	Malfunction Indicator Lamp*1		Memory*2	See page
	Normal Mode	Test Mode		
<ul style="list-style-type: none"> • Open or short in injector circuit • Fuel line pressure (injector leak, blockage) • Mechanical system malfunction (skipping teeth of timing belt) • Ignition system • Compression pressure (foreign object caught in valve) • Volume air flow meter (air intake) • ECM 	ON	ON	○	EG-428
<ul style="list-style-type: none"> • Open or short in injector circuit • Fuel line pressure (injector leak, blockage) • Mechanical system malfunction (skipping teeth of timing belt) • Ignition system • Compression pressure (foreign object caught in valve) • Volume air flow meter (air intake) • ECM 				
<ul style="list-style-type: none"> • Open or short in heater circuit of sub heated oxygen sensor • Sub heated oxygen sensor • ECM 	ON	N.A.	○	EG-434
<ul style="list-style-type: none"> • Open or short in sub heated oxygen sensor circuit • Sub heated oxygen sensor • ECM 	ON	ON		
<ul style="list-style-type: none"> • Open or short in heater circuit of main heated oxygen sensor (Rr) • Main heated oxygen sensor (Rr) heater • ECM 	ON	N.A.	○	EG-419
<ul style="list-style-type: none"> • (Main heated*3) oxygen sensor (Rr) circuit • (Main heated*3) oxygen sensor (Rr) 	ON	ON		

*1, 2, 3: See page [EG-396](#).

DTC No.	Number of MIL Blinks	Circuit	Diagnostic Trouble Code Detecting Condition
31	 BE3933	Volume Air Flow Meter Signal	All conditions below are detected: (a) No volume air flow meter signal to ECM for 2 sec. when engine speed is above 300 rpm (b) Engine stall
35	 BE3933	Barometric Pressure Sensor Signal	Open or short in BARO sensor circuit for 0.5 sec. or more
41	 BE3934	Throttle Position Sensor Signal	Open or short in throttle position sensor circuit for 0.5 sec. or more
42	 BE3934	No.1 Vehicle Speed Sensor Signal (for A/T)	All conditions below are detected continuously for 8 sec. or more: (a) No.1 vehicle speed signal: 0 km/h (mph) (b) Engine speed: 3,000 rpm or more (c) Park/neutral position switch: OFF (d) Stop Light switch: OFF
		No.1 Vehicle Speed Sensor Signal (for A/T)	All conditions below are detected continuously for 8 sec. or more: (a) No.1 vehicle speed signal: 0 km/h (mph) (b) Engine speed: 2,000 rpm and 5,000 rpm (c) Engine coolant temp.: 80°C (176°F) or more (d) Load driving
43	 BE3934	Starter Signal	No starter signal to ECM
52	 BE3935	Knock Sensor Signal (front side)	No. No.1 knock sensor signal to ECM for 4 crank revolutions with engine speed between 1,600 rpm and 5,200 rpm
53	 BE3935	Knock Control Signal	Engine control computer (for knock control) malfunction at engine speed between 650 rpm and 5,200 rpm
55	 BE3935	Knock Sensor Signal (rear side)	No No.2 knock sensor signal to ECM for 4 crank revolutions with engine speed between 1,600 rpm and 5,200 rpm

Trouble Area	Malfunction Indicator Lamp*1		Memory*2	See page
	Normal Mode	Test Mode		
<ul style="list-style-type: none"> • Open or short in volume air flow meter circuit • Volume air flow meter • ECM 	ON	N.A.	○	EG-438
<ul style="list-style-type: none"> • ECM 	ON	ON	○	EG-441
<ul style="list-style-type: none"> • Open or short in throttle position sensor circuit • Throttle position sensor • ECM 	ON	ON	○	EG-442
<ul style="list-style-type: none"> • No.1 vehicle speed sensor • Telltale light RH • Open or short in No.1 vehicle speed sensor circuit • ECM 	OFF	OFF	○	EG-445
<ul style="list-style-type: none"> • Open or short in starter signal circuit • Open or short in ignition switch or starter relay circuit • ECM 	N.A.	OFF	X	EG-448
<ul style="list-style-type: none"> • Open or short in No.1 knock sensor circuit • No.1 knock sensor (looseness) • ECM 	ON	N.A.	○	EG-450
<ul style="list-style-type: none"> • ECM 	ON	N.A.	X	EG-450
<ul style="list-style-type: none"> • Open or short in No.2 knock sensor circuit • No.2 knock sensor (looseness) • ECM 	ON	N.A.	○	EG-450

*1, 2: See page [EG-396](#).

DTC No.	Number of MIL Blinks	Circuit	Diagnostic Trouble Code Detecting Condition
71	 BE3937	EGR System Malfunction	EGR gas temp. is 70°C (158°F) or less for 1 — 4 min. under conditions (a) and (b): (2 trip detection logic)*4 (a) Engine Coolant temp.: 63°C (145°F) or more (b) EGR operation possible (Example A/T in 3rd speed (5th for M/T), A/C ON, 96 km/h (60 mph), Flat road)
78	 BE3937	Fuel Pump Control Signal	(1) Open or short in fuel pump circuit for 1 sec. or more with engine speed 1,000 rpm or less (2 trip detection logic)*4
			(2) Open in input circuit of fuel pump ECU (FPC) with engine speed 1,000 rpm or less (2 trip detection logic)*4
			(3) Open or short in diagnostic signal line (DI) of fuel pump ECU with engine speed 1,000 rpm or less (2 trip detection logic)*4
51	 BE3935	Switch Condition Signal	(1) 3 sec. or more after engine starts, with closed throttle position switch OFF (IDL1) (2) Park/neutral position switch: OFF (Shift position in "R", "D", "2", or "L" position) (3) A/C switch ON

*1: "ON" displayed in the diagnostic mode column indicates that the Malfunction Indicator Lamp is lit up when a malfunction is detected. "OFF" indicates that the "CHECK" does not light up during malfunction diagnosis, even if a malfunction is detected. "N.A." indicates that the item is not included in malfunction diagnosis.

*2: "○" in the memory column indicates that a diagnostic trouble code is recorded in the ECM memory when a malfunction occurs. "x" indicates that a diagnostic trouble code is not recorded in the ECM memory even if a malfunction occurs. Accordingly, output of diagnostic results in normal or test mode is done with the IG switch ON.

*3: Only for California specification vehicles.

Trouble Area	Malfunction Indicator Lamp*1		Memory*2	See page
	Normal Mode	Test Mode		
<ul style="list-style-type: none"> • Open in EGR gas temp. sensor circuit • Short in VSV circuit for EGR • EGR hose disconnected, valve stuck • Clogged EGR gas passage • ECM 	ON	ON	○	EG-453
<ul style="list-style-type: none"> • Open or short in fuel pump ECU circuit • Fuel pump ECU • Fuel pump • ECM power source circuit • ECM 	OFF	ON	○	EG-457
<ul style="list-style-type: none"> • A/C switch circuit • Throttle position sensor IDL circuit • Park/neutral position switch circuit • Accelerator pedal and cable • ECM 	N.A.	OFF	X	EG-460

*4: This indicates items for which "2 trip detection logic" is used. With this logic, when a logic malfunction is first detected, the malfunction is temporarily stored in the ECM memory. If the same case is detected again during the second drive test, this second detection causes the Malfunction Indicator Lamp to light up. The 2 trip repeats the same mode a 2nd time. (However, the IG switch must be turned OFF between the 1st trip and 2nd trip).

In the Test Mode, the Malfunction Indicator Lamp lights up the 1st trip a malfunction is detected.

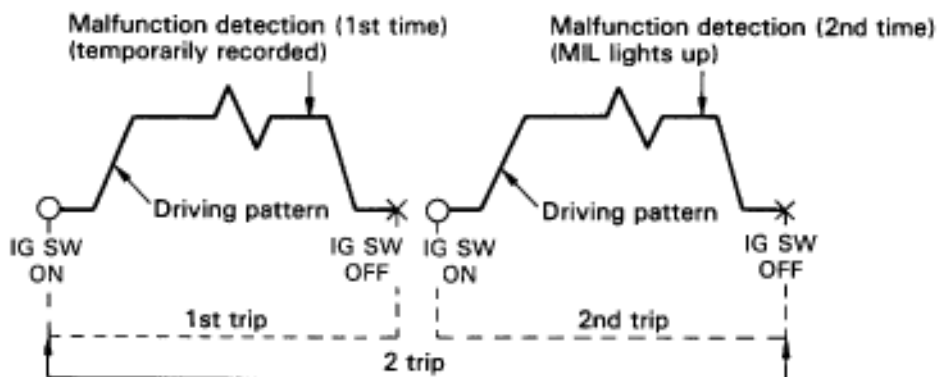

FAIL-SAFE CHART

If any of the following codes is detected, the ECM enters fail-safe mode.

DTC No.	Fail-Safe Operation	Fail-Safe Deactivation Conditions
14	Fuel cut	1 IGF detected in 3 consecutive ignitions
16	Torque control prohibited	Returned to normal condition
22	THW is fixed at 80°C (176°F)	Returned to normal condition
24	THA is fixed at 20°C (68°F)	Returned to normal condition
31	<ul style="list-style-type: none"> • Ignition timing fixed at 10° BTDC • Injection time fixed: (Starting....9 msec. (IDL ON....3.6 msec. (IDL OFF....6.7 msec. 	KS input 15 times/sec. or more
35	Atmospheric pressure is fixed at 101.3 kPa (760 mmHg, 29.92 in.Hg)	Returned to normal condition
41	VTA1 is fixed at 0°	<p>The following must each be repeated at least 2 Times consecutively:</p> <ul style="list-style-type: none"> • 0.25 V ⊕ VTA ⊕ 0.95 V • IDL: ON
52	Max. timing retardation	IG switch OFF
53	Max. timing retardation	Returned to normal condition
55	Max. timing retardation	IG switch OFF

Back-Up Function

If there is trouble with the program in the ECM and the ignition signals (IGT) are not output from the microcomputer, the ECM controls fuel injection and ignition timing at predetermined levels as a back-up function to make it possible to continue to operate the vehicle.

Furthermore, the injection duration is calculated from the starting signal (STA) and the throttle position signal (IDL). Also, the ignition timing is fixed at the initial ignition timing, 10° BTDC, without relation to the engine speed.

HINT: if the engine is controlled by the back-up function, the malfunction indicator lamp lights up to warn the driver of the malfunction but the diagnostic trouble code is not output.

CHECK FOR INTERMITTENT PROBLEMS

As described in the preceding paragraph, abnormality detection ability in the test mode is increased compared to that in the normal mode, so that when intermittent problems occur in the ECM signal circuits (G1, G2, NE, THW, THA, VTA1) shown in the table below, the appropriate diagnostic trouble code is output.

Accordingly, when the diagnostic trouble codes shown in the table opposite (13, 22, 24, 41) are output during the diagnostic trouble code check, and inspection of the appropriate circuits reveals no abnormality, check for intermittent problems as described below.

By checking for intermittent problems, the place where intermittent problems are occurring due to poor contacts can be isolated.

DTC	Circuit
13	G, NE signal circuit (No.2)
22	Engine coolant temp. sensor circuit
24	Intake air temp. sensor circuit
41	Throttle position sensor circuit

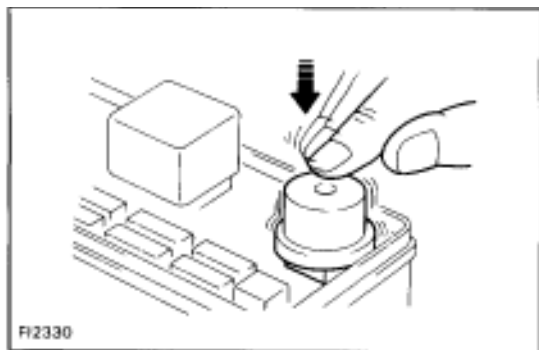
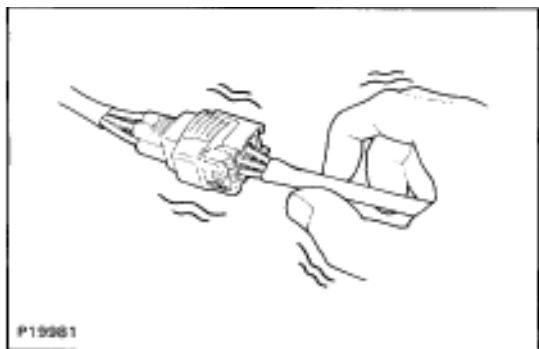

CLEAR DIAGNOSTIC TROUBLE CODES

See page [EG-387](#).

SET TEST MODE

1. With the ignition switch OFF, using SST, connect the terminals TE2 and E1 of the data link connector 2.
SST 09843-18020
2. Start the engine and check to see the malfunction indicator lamp goes off.

PERFORM A SIMULATION TEST

Using the symptom simulation (See page [IN-24](#)), apply vibration to and pull lightly on the wire harness, connector or terminals in the circuit indicated by the malfunction code.

In this test, if the malfunction indicator lamp lights up, it indicates that the place where the wire harness, connector or terminals being pulled or vibrated has a faulty contact. Check that point for loose connections, dirt on the terminals, poor fit or other problems and repair as necessary.

HINT: After cancelling out the diagnostic trouble code in memory and set the test mode, if the malfunction indicator lamp does not go off after the engine is started, check thoroughly for faulty contacts, etc., then try the check again. If the malfunction indicator lamp still does not go off, check and replace ECM.

BASIC INSPECTION

In many cases, by carrying out the basic engine check shown in the following flow chart, the location causing the problem can be found quickly and efficiently. Therefore, use of this check is essential in engine troubleshooting.

If there is a problem, and a normal code is displayed, proceed to the matrix chart of problem symptoms on page [EG-408](#). Make sure that every likely cause of the problem is checked.

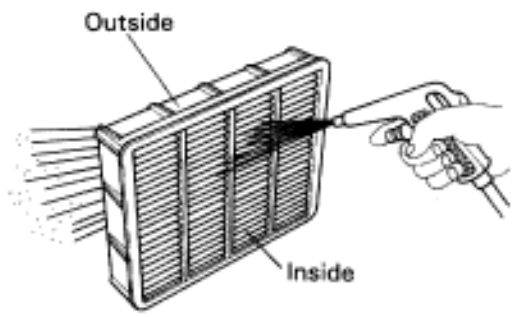
1 Is battery positive voltage 11 V or more when engine is stopped?	
YES	NO Charge or replace battery.
2 Is engine cranked?	
YES	NO Proceed to matrix chart of problem symptoms on page EG-408 .
3 Does engine start?	
YES	NO Go to step 7 .
4 Check air filter.	
 <p>MA0688</p>	<p>P Remove air filter.</p> <p>C Visually check that the air filter is not excessive dirty or oily.</p> <p>Hint If necessary, clean the air filter with compressed air. First blow from inside thoroughly, then blow from outside of the air filter.</p>
OK	NG Repair or replace.

5 Check idle speed.

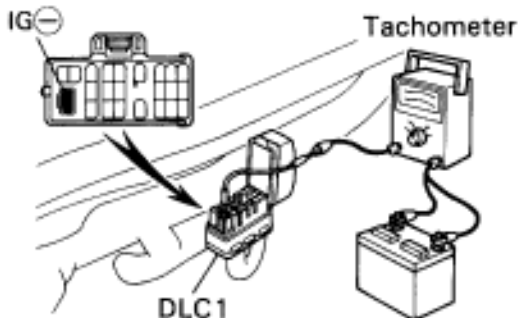

P11291

- P**
- (1) Shift transmission into "N" position.
 - (2) Warm up engine to normal operating temperature.
 - (3) Switch OFF all accessories.
 - (4) Switch OFF air conditioning.
 - (5) Connect tachometer test probe to terminal IG \ominus of data link connector 1.

C Check idle speed.

OK Idle speed: 700 ± 50 rpm

Caution

- NEVER allow tachometer test probe to touch ground as it could result in damage to igniter and/or ignition coil.
- As some tachometers are not compatible with this ignition system, we recommend that you confirm compatibility of your unit before use.

OK

NG

Proceed to matrix chart of problem symptoms on page EG-408.

6 Check ignition timing.

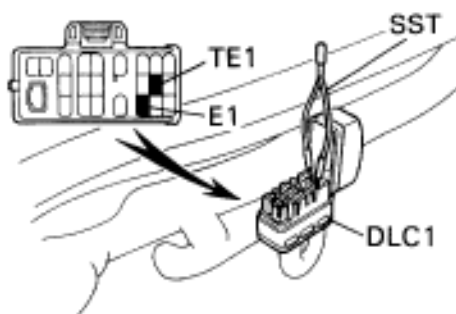
P11288
PC2630

- P**
- (1) Shift transmission into "N" position.
 - (2) Warm up engine to normal operating temperature.
 - (3) Keep the engine speed at idle.
 - (4) Using SST, connect terminals TE1 and E1 of data link connector 1.
- SST 09843-18020
- (5) Connect a timing light probe to No.1 high-tension cord.

C Check ignition timing.

OK Ignition timing: $10 \pm 2^\circ$ BTDC @ idle

OK

NG

Proceed to page EG-18 and continue to troubleshoot.

Proceed to matrix chart of problem symptoms on page EG-408.

7

Check fuel pressure.

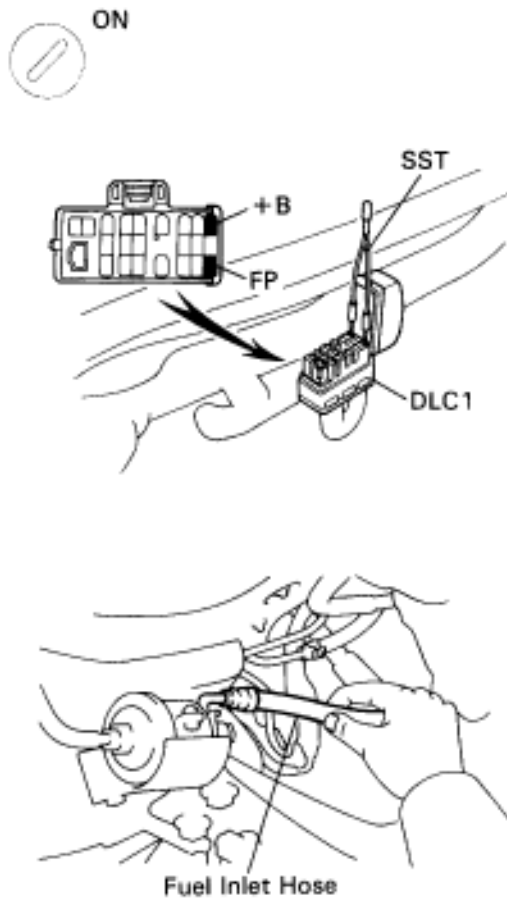

A80119
P11290
P11446

P

- (1) Be sure that there is enough fuel in the tank.
- (2) Turn ignition switch ON.
- (3) Using SST, connect terminals FP and +B of data link connector 1.
SST 09834-18020

C

Check that there is pressure in the hose from the fuel filter.

Hint

If there is fuel pressure, you will hear the sound of fuel flowing.

Caution

Never make a mistake with the terminal connection position as this will cause a malfunction.

OK

NG

Proceed to page [EG-193](#) and continue to troubleshoot.

8

Check for spark.

C

Disconnect the high-tension cord from the distributor and hold the end about 12.5 mm (1/2") from the ground. See if spark occurs while the engine is being cranked.

Hint

To prevent excess fuel being injected from the injectors during this test, don't crank the engine for more than 1 — 2 seconds at a time.

OK

NG

Proceed to page [IG-4](#) and continue to troubleshoot.

Proceed to matrix chart of problem symptoms on page [EG-408](#).

PARTS LOCATION

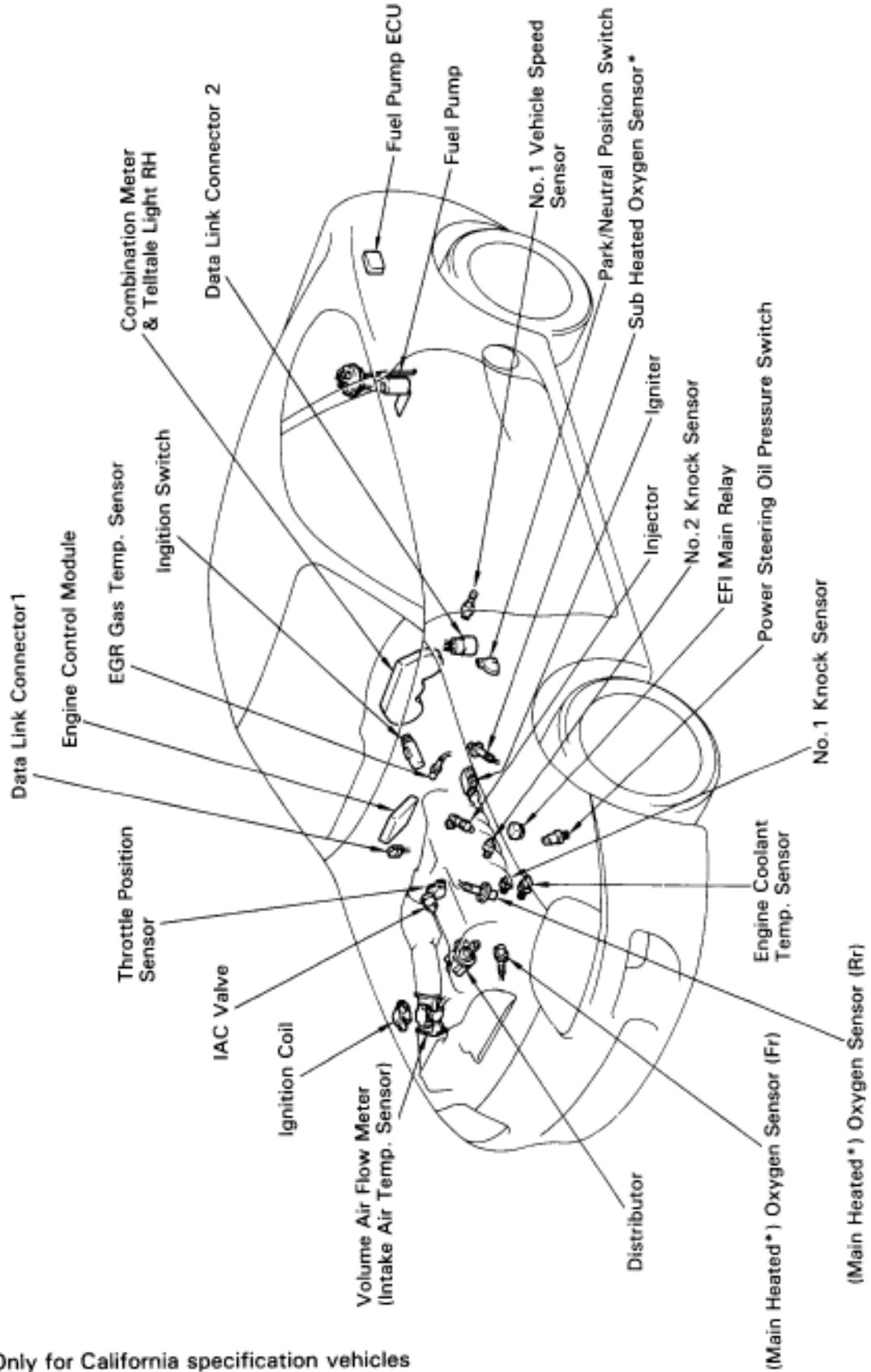

F16968

*: Only for California specification vehicles

STANDARD VALUE OF ECM TERMINALS

Connectors of the engine control module are waterproof and are the bolt type.

For waterproof type connectors, in order to measure the voltage of ECM terminals and the resistance of connected parts, connect the inspection sub wire harness between the ECM and vehicle wire harness, then do the inspection.

The inspection method of inserting a tester probe from the other side of connector significantly reduces the waterproof performance.

Disconnect the connector by fully loosening the bolt.

PREPARATION

1. Turn the ignition switch OFF.
2. Turn up the passenger side floor carpet.
(See page [EG-253](#))
3. Remove the ECM protector.
4. Disconnect the connector from the ECM.

After completely loosening the bolt, the 2 parts of the connector can be separated.

NOTICE:

- Do not pull the wire harness when disconnecting the connector.
- When disconnecting the connector, the ECM's back-up power source is cut off, so the malfunction codes, etc. recorded in the ECM memory are cancelled.
- Never insert a tester probe or male terminal used for inspection purposes into the female terminal of the vehicle wire harness. Otherwise, the female terminal may be widened, which can result in faulty connection.

5. Connect SST (check harness "A") between the ECM and connector of the vehicle wire harness.

SST 09990-01000

HINT: The arrangement of the check connector terminals are the same as those of the ECM.

See page [EG-405](#).

6. Disconnect the SST.
SST 09990-01000
7. Reconnect the connector to the ECM.
 - (a) Match the male connector correctly with the female connector, then press them together.
 - (b) Tighten the bolt.
Make sure the connector is completely connected by tightening the bolt until there is a clearance of less than 1 mm (0.04 in.) between the bottom of the male connector and the end of the female connector.
8. Install the ECM protector and floor carpet.

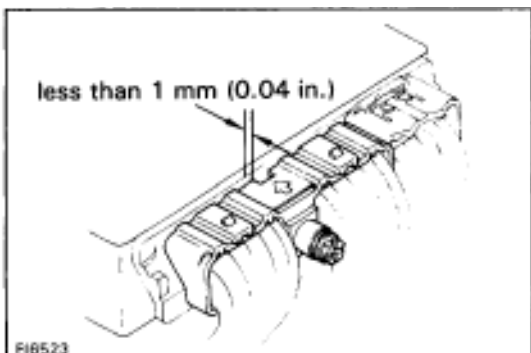
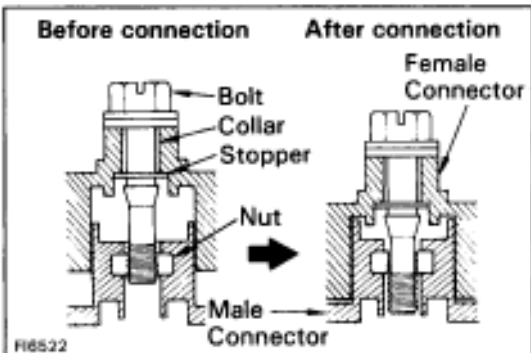
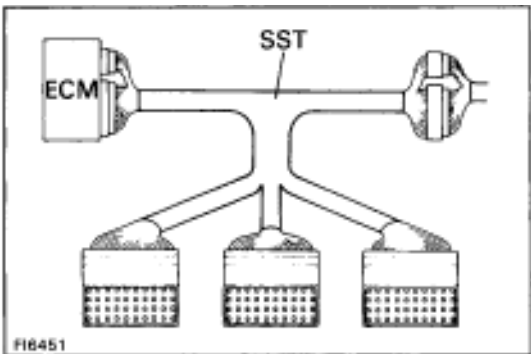
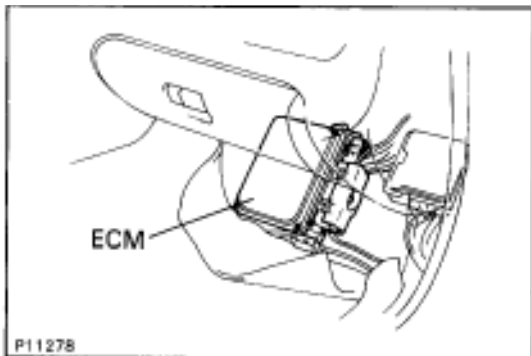

STANDARD VALUE OF ECM TERMINALS

ECM Terminals		
E9 (B)		E10 (A)
FIS460		
Symbols (Terminals No.)	STD Voltage (V)	Condition
BATT (A33) – E1 (B69)	9 ~ 14	Always
IGSW (A1) } + B (A31) } – E1 (B69)	9 ~ 14	IG switch ON
VCC (B41) – E2 (B65)	4.5 ~ 5.5	IG switch ON
IDL1 (B64) – E2 (B65)	0 ~ 3.0	IG switch ON and apply vacuum to the throttle opener Throttle valve fully closed
	9 ~ 14	IG switch ON Throttle valve fully opened
VTA1 (B43) – E2 (B65)	0.3 ~ 0.8	IG switch ON Throttle valve fully closed
	3.2 ~ 4.9	IG switch ON Throttle valve fully opened
KS (B66) – E1 (B69)	Pulse generation (See page EG-439)	Idling
THA (B45) – E2 (B65)	0.5 ~ 3.4	Idling, Intake air temp. 0°C (32°F) to 80°C (176°F)
THW (B44) – E2 (B65)	0.2 ~ 1.0	Idling, Engine coolant temp. 60°C (140°F) to 120°C (248°F)
STA (B77) – E1 (B69)	6.0 or more	Cranking
# 10 (B20), # 20 (B19) # 30 (B18), # 40 (B17) – E01 (B80) # 50 (B16), # 60 (B15)	9 ~ 14	IG switch ON
	Pulse generation (See page EG-472)	Idling
IGT (B57) – E1 (B69)	Pulse generation (See page EG-415)	Idling
IGF (B58) – E1 (B69)	Below 2.0	IG switch ON
	Pulse generation (See page EG-415)	Idling
G1 (B26), G2 (B25) – G ⊖ (B7)	Pulse generation (See page EG-410)	Idling
NE (B27) – G ⊖ (B7)	Pulse generation (See page EG-410)	Idling
M-REL (A24) – E1 (B69)	9 ~ 14	IG switch ON
FPC (A22) – E1 (B69)	Below 1.5	IG switch ON
	Pulse generation (4.5 ~ 5.5)	Idling
DI (A21) – E1 (B69)	7.0 or more	Idling

Symbols (Terminals No.)	STD Voltage (V)	Condition
ACIS (B39)-E01 (B80)	9 ~ 14	IG switch ON
EVAP (B74)-E01 (B80)	9 ~ 14	IG switch ON
EGR (B75)-E01 (B80)	Below 2.0	Idling
	9 ~ 14	Engine speed at 3,500 rpm
ISC1 (B35), ISC2 (B34) ISC3 (B33), ISC4 (B32) -E01 (B80)	Pulse generation (See page EG-475)	Idling, when A/C switch ON or OFF
VF1 (B29), VF2 (B28)-E1 (B69)	1.8 ~ 3.2	Maintain engine speed at 2,500 rpm for 2 minutes after warming up then return to Idling
OX1 (B48), OX2 (B47)-E1 (B69) OX3 (A30)*	Pulse generation (See page EG-423)	Maintain engine speed at 2,500 rpm for 2 minutes after warming up
HT1 (B73)*, HT2 (B72)*-E01 (B80) HT3 (A36)*	Below 3.0	Idling
	9 ~ 14	IG switch ON
KNK1 (B50), KNK2 (B49)-E1 (B69)	Pulse generation (See page EG-452)	Idling
NSW (B76)-E1 (B69)	9 ~ 14	IG switch ON Other shift position in "P", "N" position
	0 ~ 3.0	IG switch ON Shift position in "P", "N" position
SP1 (A2)-E1 (B69)	Pulse generation (See page EG-445)	IG switch ON Rotate driving wheel slowly
TE1 (A20)-E1 (B69)	9 ~ 14	IG switch ON
TE2 (A19)-E1 (B69)	9 ~ 14	IG switch ON
W (A6)-E1 (B69)	9 ~ 14	Idling
	0 ~ 3.0	IG switch ON
OD1 (A12)-E1 (B69)	9 ~ 14	IG switch ON
A/C (A34)-E1 (B69)	7.5 ~ 14	A/C switch OFF
	0 ~ 1.5	A/C switch ON (At idling)
ACMG (A23)-E1 (B69)	0 ~ 3.0	A/C switch ON (At idling)
	9 ~ 14	A/C switch OFF
FPU (B36)*-E01 (B80)	9 ~ 14	IG switch ON
	Below 2.0	Restarting at high engine coolant temp.
ELS (A15)-E1 (B69)	7.5 ~ 14	Defogger switch and taillight switch ON
	0 ~ 1.5	Defogger switch and taillight switch OFF

*: Only for California specification vehicles

REFERENCE VALUE OF ECM DATA

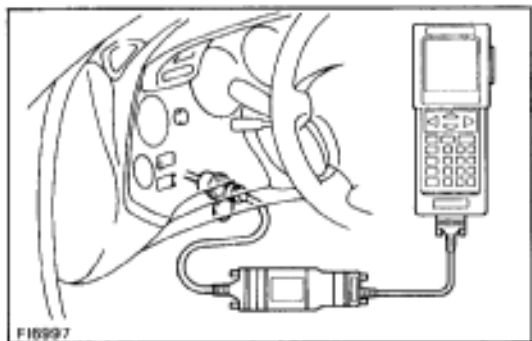

HINT: ECM data can be monitored by TOYOTA hand-held tester.

1. Hook up the TOYOTA hand-held tester to DLC2.
2. Monitor ECM data by following the prompts on the tester screen.

Please refer to the TOYOTA hand-held tester operator's manual for further details.

REFERENCE VALUE

Item	Inspection condition	Reference value
INJECTOR	Engine cold to hot Engine idling at normal operating temp.* ¹	Gradually decreases Approx. 2.0 msec.
IGNITION	Increase engine speed	Gradually increases
IAC STEP #	Engine idling at normal operating temp.* ¹ A/C switch ON A/T shifting in "D" position Ignition switch ON (Engine off)	20 ~ 25 steps Step increases Step increases Approx. 125 steps
ENGINE SPEED	RPM kept stable (Comparison with tachometer)	No great changes
VAF	Engine idling at normal operating temp.* ¹ Increase engine speed	Approx. 35 ms Gradually decreases
ECT	Engine at normal operating temp.	75-95°C (185-203°F)* ²
THROTTLE	Closed throttle position Wide open throttle From closed throttle position to wide open throttle	Below 5° Above 70° Gradually increases
VEHICLE SPD	During driving (Comparison with speedometer)	No large differences
TARGET A/FL* ⁵	Engine idling at normal operating temp.	2.50 ± 1.25 V* ³
TARGET A/FR* ⁶	Engine idling at normal operating temp.	2.50 ± 1.25 V* ³
A/F FB LEFT* ⁵	RPM stable at 2500 rpm with normal operating temp.	ON
A/F FB RIGHT* ⁶	RPM stable at 2500 rpm with normal operating temp.	ON
KNOCK FB	Depress throttle pedal suddenly during idling	ON
STA SIGNAL	During cranking	ON
CTP SIGNAL	Closed throttle position	ON
A/C SIGNAL	A/C switch ON	ON
PNP SIGNAL* ⁴	When shifting from "P" or "N" position into a position other than "P" or "N"	GEAR
O X L* ⁵	RPM stable at 2500 rpm with normal operating temp.	RICH LEAN is repeated
O X R* ⁶	RPM stable at 2500 rpm with normal operating temp.	RICH LEAN is repeated

*¹: If the engine coolant temp. sensor circuit is open or shorted, the ECM assumes an engine coolant temp. value of 80°C (176°F).

*²: When feedback control is forbidden, 0 V is displayed.

*³: A/T only

*⁴: Oxygen sensor (Front)

*⁵: Oxygen sensor (Rear)

CIRCUIT INSPECTION

DTC 12 G NE Signal Circuit (No.1)

CIRCUIT DESCRIPTION

The distributor in the Engine Control System contains 3 pick-up coils (G1, G2 and NE).

The G1, G2 signals inform the ECM of the standard crankshaft angle.

The NE signals inform the ECM of the crankshaft angle and the engine speed.

DTC No.	Diagnostic Trouble Code Detecting Condition	Trouble Area
12	No "NE" or "G1" and "G2" signal to ECM for 2 sec. or more after cranking	<ul style="list-style-type: none"> • Open or short in NE, G circuit • Distributor
	Open in "G ±" circuit	<ul style="list-style-type: none"> • Open or short in STA circuit • ECM

WIRING DIAGRAM

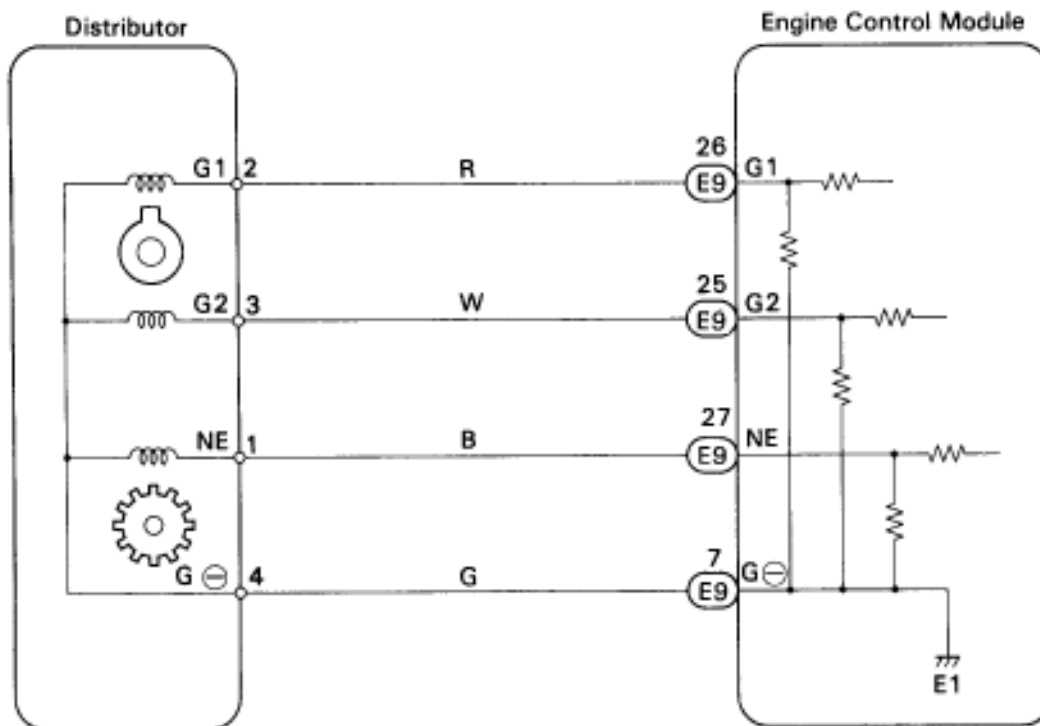

INSPECTION PROCEDURE

1

Check resistance of each pickup coils in distributor.

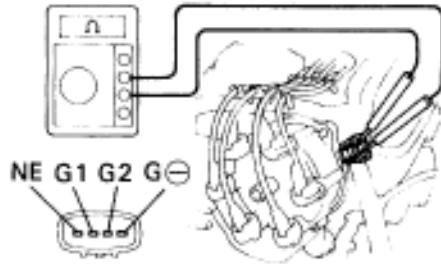

- P** Disconnect distributor connector.
- C** Measure resistance between each terminal shown in the table below.

	Resistance	
	Cold	Hot
G1 pickup coil (G1-G±)	125 ~ 200 Ω	160 ~ 235 Ω
G2 pickup coil (G2-G±)	125 ~ 200 Ω	160 ~ 235 Ω
NE pickup coil (NE-G±)	155 ~ 250 Ω	190 ~ 290 Ω

“Cold” is from — 10°C (14°F) to 50°C (122°F) and “Hot” is from 50°C (122°F) to 100°C (212°F).

FI6631

Reference

INSPECTION USING OSCILLOSCOPE

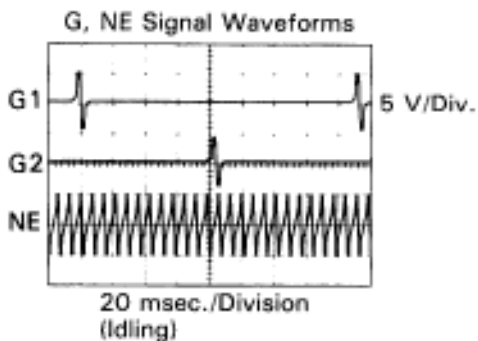

- During cranking or idling, check waveforms between terminals G1, G2, NE and G ± of engine control module

HINT: The correct waveforms are as shown.

FI6519

OK

NG

Replace Distributor

2

Check for open and short in harness and connector between engine control module and distributor (See page [IN-30](#)).

OK

NG

Repair or replace harness or connector

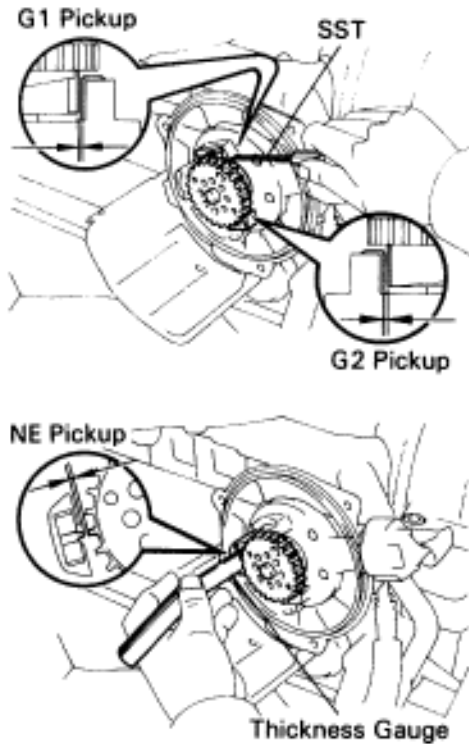
3**Check air gap.**P10579
P10580**P** Remove distributor cap & rotor.**C** Using SST (G1 and G2 pickups) and a thickness gauge (NE pickup), measure the air gap between the signal rotor and pickup coil projection.

SST 09240-00020 for G1 and G2 pickups

OK Air gap: 0.2 — 0.5 mm (0.008 — 0.020 in.)**OK****NG**

Replace distributor housing assembly

Check and replace engine control module.

DTC 13 G NE Signal Circuit (No.2)

CIRCUIT DESCRIPTION

See G, NE signal circuit (No. 1) on page [EG-409](#).

DTC No.	Diagnostic Trouble Code Detecting Condition	Trouble Area
13	No NE signal to ECM for 0.1 sec. or more at 1,000 rpm or more	<ul style="list-style-type: none"> • Open or short in NE circuit • Distributor • ECM
	NE signal does not pulse 12 times to ECM during the interval between G1 and G2 pulses	

DIAGNOSIS

This code indicates that a intermittent problems of the G, NE signal from the distributor to the ECM has occurred, but that it has returned to normal. Note that although this problem may not necessarily appear at the time of inspection, it cannot be ignored because this diagnostic trouble code is output, indicating that there is or was a malfunction in the G, NE signal circuit; this "malfunction" is usually a loose connector.

The distributor connector and the NE terminal of the ECM connector must therefore be checked for the following:

1. Loose connectors
2. Dirty connector terminals
3. Loose connector terminals

DTC 14 Ignition Signal Circuit

CIRCUIT DESCRIPTION

The ECM determines the ignition timing, turns on Tr₁ at a predetermined angle (°CA) before the desired ignition timing and outputs an ignition signal (IGT) "1" to the igniter.

Since the width of the IGT signal is constant, the dwell angle control circuit in the igniter determines the time the control circuit starts primary current flow to the ignition coil based on the engine rpm and ignition timing one revolution ago, that is, the time the Tr₂ turns on.

When it reaches the ignition timing, the ECM turns Tr₁ off and outputs the IGT signal "0".

This turns Tr₂ off, interrupting the primary current flow and generating a high voltage in the secondary coil which causes the spark plug to spark. Also, by the counter electromotive force generated when the primary current is interrupted, the igniter sends an ignition confirmation signal (IGF) to the ECM.

The ECM stops fuel injection as a fail safe function when the IGF signal is not input to the ECM.

DTC No.	Diagnostic Trouble Code Detecting Condition	Trouble Area
14	No IGF signal to ECM for 6 consecutive IGT signals	<ul style="list-style-type: none"> • Open or short in IGF OR IGT circuit from igniter to ECM • Igniter • ECM

WIRING DIAGRAM

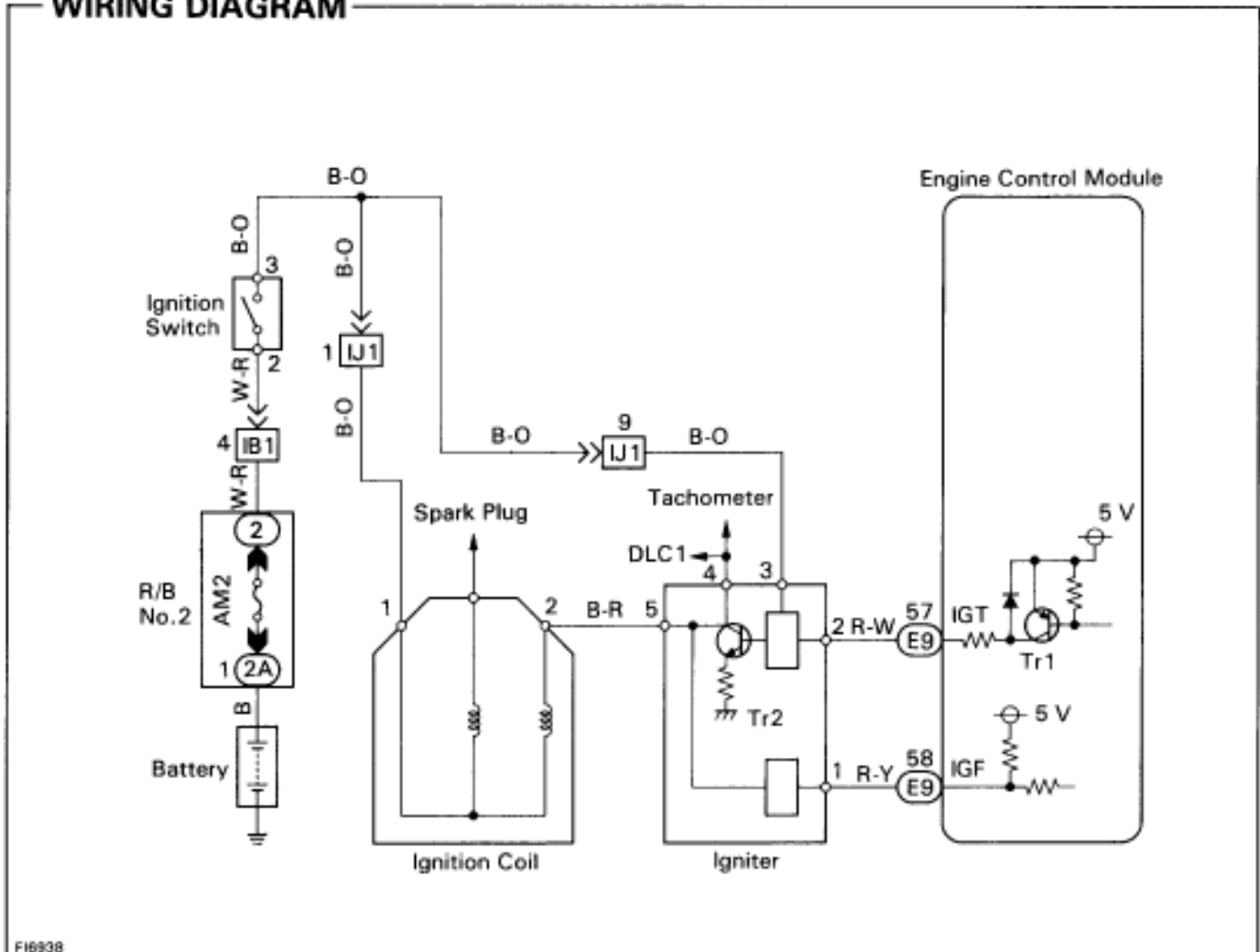

INSPECTION PROCEDURE

1**Check for spark.****C**

Disconnect the high-tension cord from the distributor, hold its end about 12.5 mm (1/2") from the ground, see if spark occurs while the engine is being cranked.

OK

Spark should be generated.

Notice

To prevent excess fuel being injected from the injectors during this check. Don't crank the engine for more than 1 — 2 seconds at a time.

OK**NG**

Go to step **4**.

2

Check for open and short in harness and connector in IGF signal circuit between engine control module and igniter (see page IN-30).

OK**NG**

Repair or replace harness or connector.

3

Disconnect igniter connector and check voltage between terminal IGF of engine control module connector and body ground.

ON

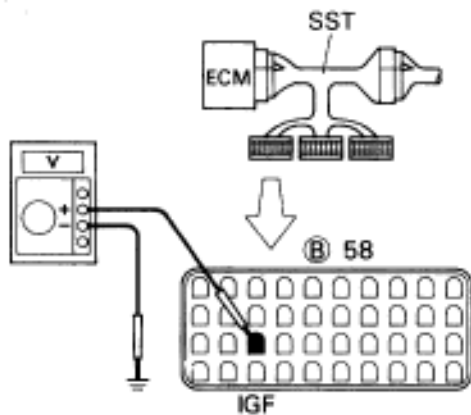

BE0653 F16621

P

- (1) Disconnect igniter connector.
- (2) Connect SST (check harness "A").
See page EG-404
- SST 09990-01000
- (3) Turn ignition switch ON.

C

Measure voltage between terminal IGF of engine control module connector and body ground.

OK

Voltage: 4.5 ~ 5.5 V

NG**OK**

Replace igniter.

Check and replace engine control module.

4**Check voltage between terminal IGT of engine control module connector and body ground.**

START

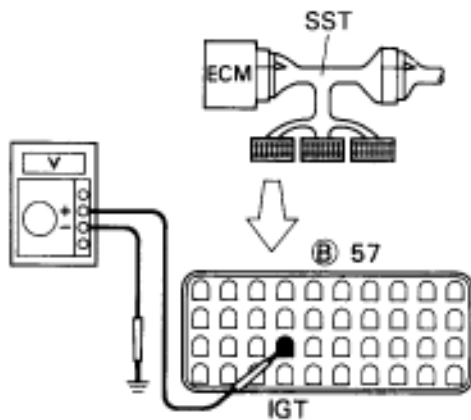
BE6653
FI0614

P Connect SST (check harness "A").
See page [EG-404](#)
SST 09990-01000

C Measure voltage between terminal IGF of engine control module connector and body ground when engine is cranked.

OK Voltage: 0.5 — 1.0 V
(Neither 0 V nor 5 V)

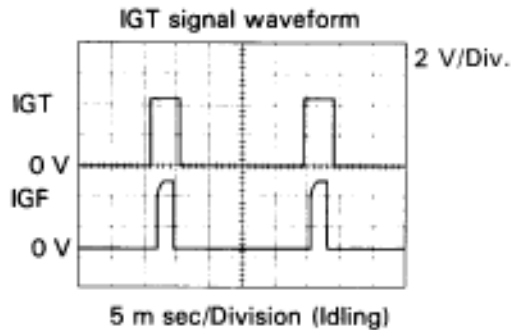
Reference**INSPECTION USING OSCILLOSCOPE**

FI6605

• During cranking or idling, check waveforms between terminal IGT and E1 of engine control module.

HINT: The correct rectangular waveforms are as shown.

OK**NG** Go to step **8**.**5****Check voltage between terminal 3 of igniter connector and body ground.**

ON and START

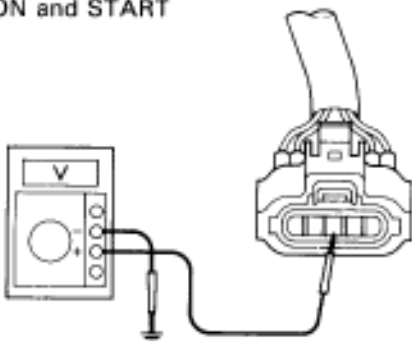
BE6653
FI6438

P Disconnect igniter connector.

C Measure voltage between terminal 3 of igniter connector and body ground, when ignition switch is turned to "ON" and "START" position.

OK Voltage: 9 — 14 V

OK**NG** Check and repair igniter power source circuit.

6 Check for open and short in harness and connector between ignition switch and ignition coil, ignition coil and igniter (See page **IN-30**).

OK

NG Repair or replace harness or connector.

7 Check ignition coil.

Primary Coil

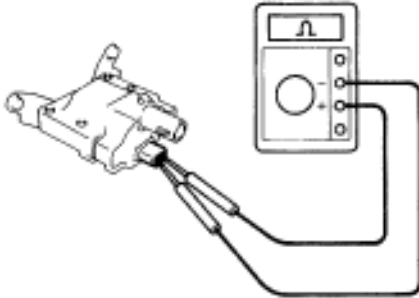

Secondary Coil

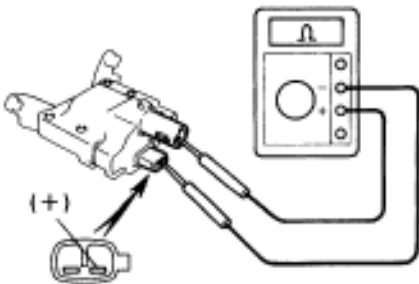

P11567
P11573

P Disconnect ignition coil connector.

- C**
- (1) Check primary coil.
Measure resistance between terminals of ignition coil connector.
 - (2) Check secondary coil.
Measure resistance between terminal ⊕ of ignition coil connector and high-tension terminal.

OK

		Resistance
(a) Primary Coil	Cold	0.36 ~ 0.55 Ω
	Hot	0.45 ~ 0.65 Ω
(b) Secondary Coil	Cold	9.0 ~ 11.1 kΩ
	Hot	11.4 ~ 18.1 kΩ

“Cold” is from — 10°C (14°F) to 50°C (122°F) and “Hot” is from 50°C (122°F) to 100°C (212°F).

OK

NG Replace ignition coil.

Replace igniter.

8

Disconnect igniter connector and check voltage between terminal IGT of engine control module connector and body ground.

START

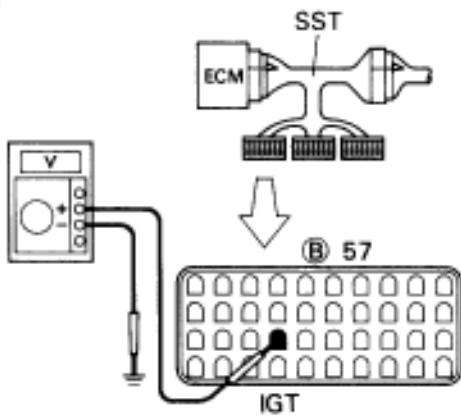
BE6653
FI6614

- P** Disconnect igniter connector.
- C** Measure voltage between terminal IGT of engine control module connector and body ground when engine is cranked.
- OK** Voltage: 0.5 — 1.0 V
(Neither 0 V nor 5 V)

Reference

INSPECTION USING OSCILLOSCOPE

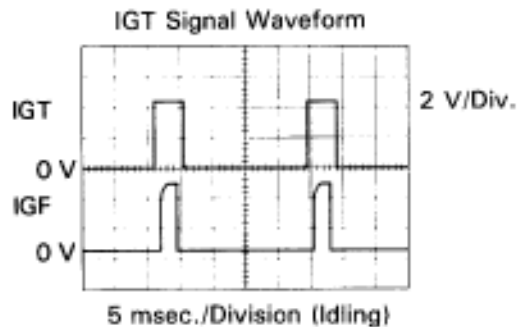

FI6605

- During cranking or idling, check waveforms between terminal IGT and E1 of engine control module.
- HINT: The correct rectangular waveforms are as shown.

NG

OK Replace igniter.

9

Check for open and short in harness and connector in IGT signal circuit between engine control module and igniter (See page [IN-30](#)).

OK

NG Repair or replace harness or connector.

Check and replace engine control module.

DTC 16 A T Control Signal Malfunction

CIRCUIT DESCRIPTION

The signal from the A/T CPU retards the ignition timing of the engine during A/T gear shifting, thus momentarily reducing torque output of the engine for smooth clutch operation inside the transmission and reduced shift shock.

DTC No.	Diagnostic Trouble Code Detecting Condition	Trouble Area
16	Fault in communications between the engine CPU and A/T CPU in the ECM	• ECM

If the ECM detects the diagnostic trouble code "16" in memory, it prohibits the torque control of the A/T which performs smooth gear shifting.

INSPECTION PROCEDURE

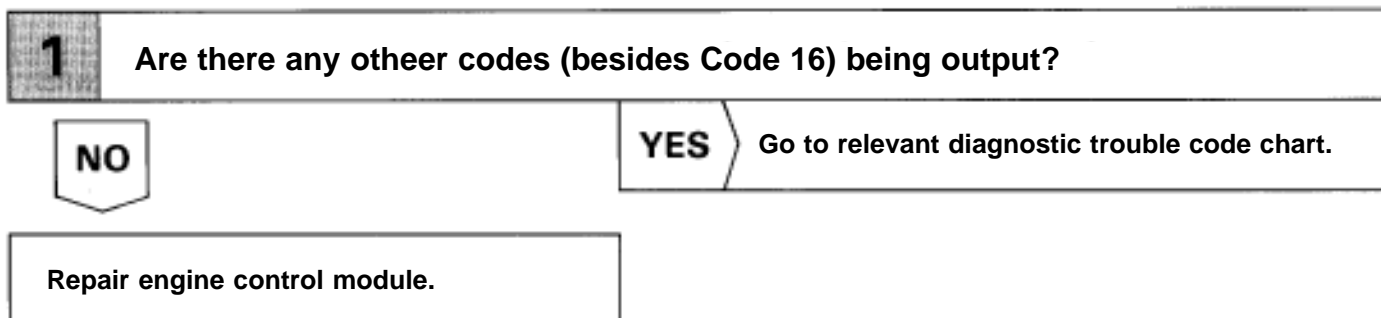

DTC 21 28 (Main Heated*1) Oxygen Sensor Circuit

CIRCUIT DESCRIPTION

To obtain a high purification rate for the Co, Hc and NOx components of the exhaust gas, a three-way catalytic converter is used, but for most efficient use of the three-way catalytic converter, the air-fuel ratio must be precisely controlled so that it is always close to the stoichiometric air-fuel ratio.

The oxygen sensor has the characteristic whereby its output voltage changes suddenly in the vicinity of the stoichiometric air-fuel ratio. This characteristic is used to detect the oxygen concentration in the exhaust gas and provide feedback to the computer for control of the air fuel ratio.

When the air-fuel ratio becomes LEAN, the oxygen concentration in the exhaust increases and the oxygen sensor informs the ECM of the LEAN condition (small electromotive force: 0 V).

When the air-fuel ratio is RICHER than the stoichiometric air-fuel ratio the oxygen concentration in the exhaust gas is reduced and the oxygen sensor informs the ECM of the RICH condition (large electromotive force: V).

The ECM judges by the electromotive force from the oxygen sensor whether the air-fuel ratio is RICH or LEAN and controls the injection duration accordingly. However, if malfunction of the oxygen sensor causes an output of abnormal electromotive force, the ECM is unable to perform accurate air-fuel ratio control.

The main heated oxygen sensors include a heater which heats the Zirconia element. The heater is controlled by the ECM. When the intake air volume is low (the temperature of the exhaust is low) current flows to the heater to heat the sensor for accurate oxygen concentration detection.)

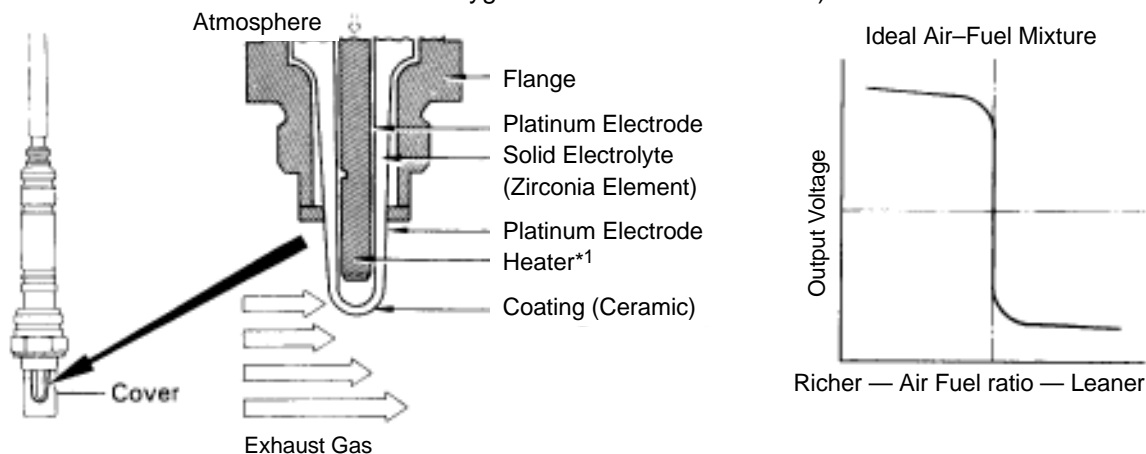

F14835
8S0076

DTC No.	Diagnostic Trouble Code Detecting Condition	Trouble Area
21 • 28	(1)*1 Open or short in heater circuit of main heated oxygen sensor for 0.5 sec. or more.	<ul style="list-style-type: none"> • Open or short in heater circuit of main heated oxygen sensor • Main heated oxygen sensor heater • ECM
	(2) (Main heated*1) oxygen sensor signal voltage is reduced to between 0.35 V and 0.70 V for 60 sec. under conditions (a) ~ (d): (2) trip detection logic)*2 (a) Engine coolant temp.: Between 80°C (176°F and 95°C (203°F) (b) Engine speed: 1,500 rpm or more (c) Load driving (Example A/T in Overdrive (5th for M/T), A/C ON, Flat road, 80 km/h (50 mph)) (d) (Main heated*1) oxygen sensor signal voltage: Alternating above and below 0.45 V	<ul style="list-style-type: none"> • (Main heated*1) oxygen sensor circuit • (Main heated*1) oxygen sensor

HINT: Diagnostic trouble code "21" is for the (main heated*1) oxygen sensor (Fr) circuit.
 Diagnostic trouble code "28" is for the (main heated*1) oxygen sensor (Rr) circuit.

*1: Main heated oxygen sensor ONLY for California specification vehicles.

*2: See page EG-397.

CIRCUIT DESCRIPTION (Cont'd)**DIAGNOSTIC TROUBLE CODE DETECTION DRIVING PATTERN**

Purpose of the driving pattern.

- (a) To simulate diagnostic trouble code detecting condition after diagnostic trouble code is recorded.
- (b) To check that the malfunction is corrected when the repair is completed confirming that diagnostic trouble code is no longer detected.

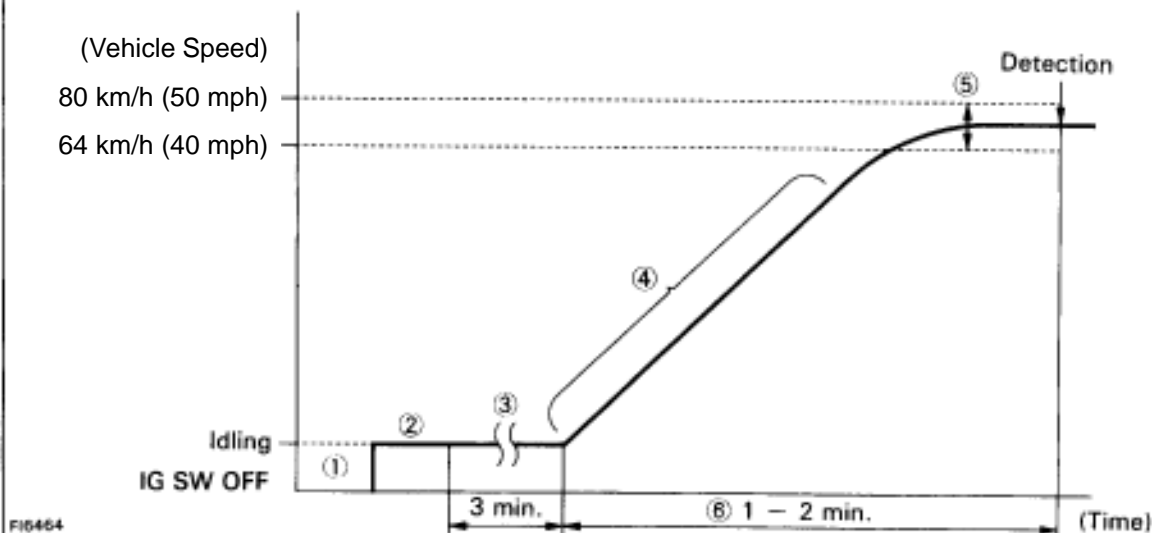
Malfunction: (Main heated) Oxygen Sensor Detection

It is vital that this test routine is adhered to detect the malfunction:

- (1) Disconnect the EFI No.1 fuse (30 A) for 10 sec. or more, with IG switch OFF. Initiate test mode (Connect terminal TE2 and E1 of data link connector 2 with IG switch OFF).
- (2) Start the engine and warm up with all ACC switched OFF.
- (3) Idle the engine for 3 min.
- (4) Accelerate gradually within the range 1,300 ~ 1,700 rpm (centered around 1,500 rpm) with the A/C switched ON and D position for A/T (5th for M/T).

HINT: • Ensure engine rpm does NOT fall below 1200 rpm.
 • Gradually depress the accelerator pedal at a suitable rate to comply with the test requirements on the above graph.
 • Never allow engine rpm to drop at any time during the test.

- (5) Maintain the vehicle speed at 64 — 80 km/h (40 — 50 mph).
- (6) Keep the vehicle running for — 2 min. after starting acceleration.

HINT: If a malfunction exists, the Malfunction Indicator Lamp will light up after approx. 60 sec. from the start of acceleration.

NOTICE: If the conditions in this test are not strictly followed, detection of the malfunction will not be possible.

*: Main heated oxygen sensor only for California specification vehicles

WIRING DIAGRAM

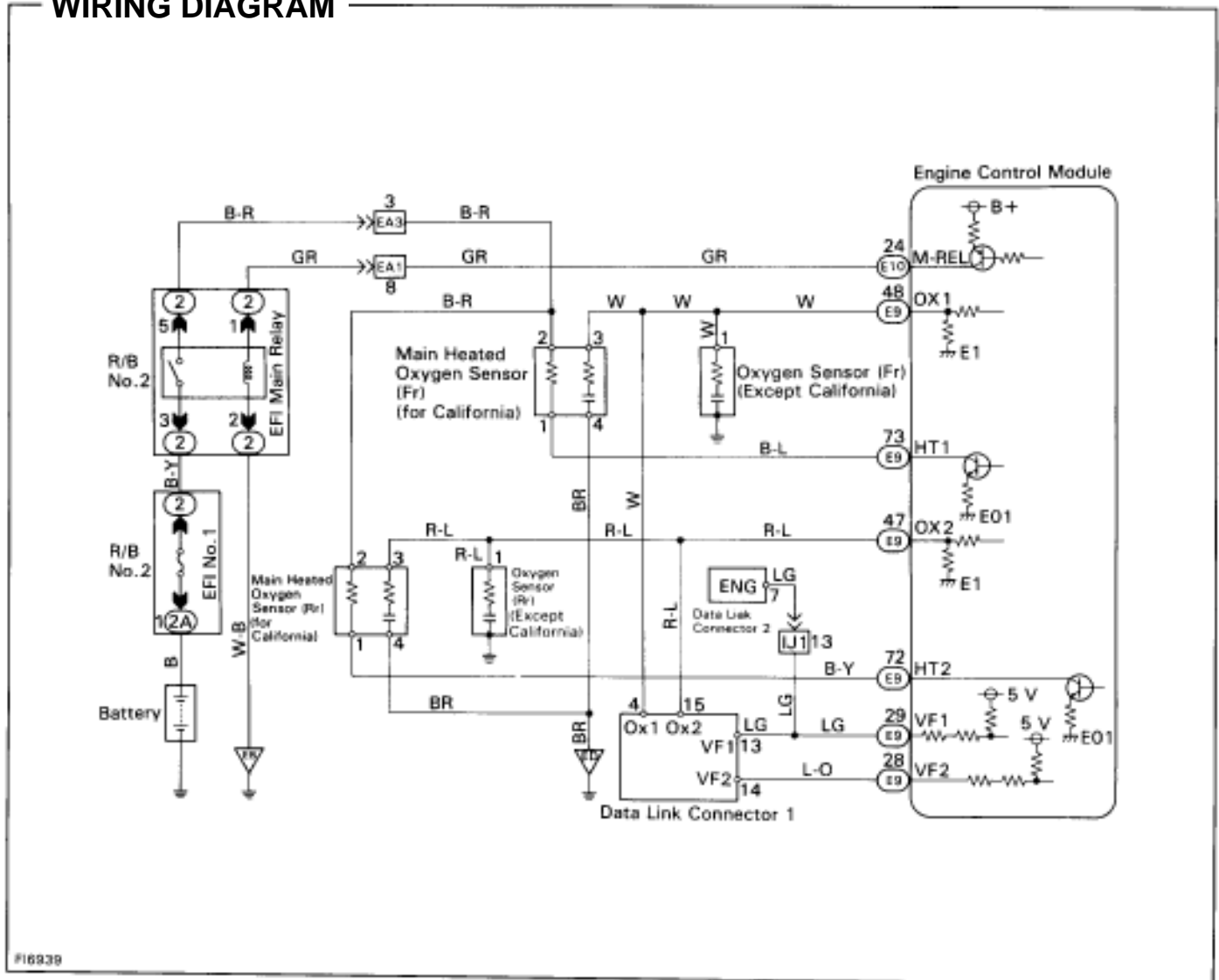

INSPECTION PROCEDURE (Except California specification vehicles)

HINT: If diagnostic trouble code "21" is output, replace oxygen sensor (Fr).

If diagnostic trouble code "28" is output, replace oxygen sensor (Rr).

1

Are there any other codes (besides code 21 or 28) being output?

NO

YES

Go to relevant diagnostic trouble code chart.

Replace oxygen sensor.

INSPECTION PROCEDURE (Only for California specification vehicles)

HINT: If diagnostic trouble code "21" is output, check the main heated oxygen sensor (Fr) circuit.

If diagnostic trouble code "28" is output, check the main heated oxygen sensor (Rr) circuit.

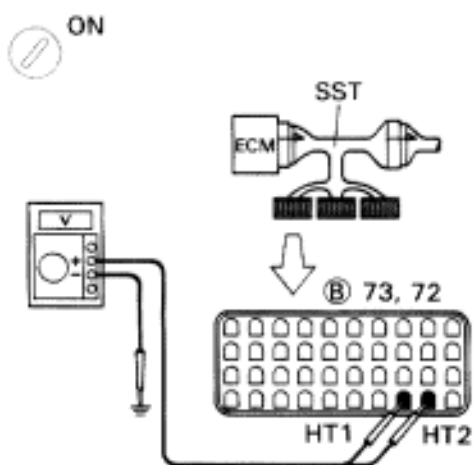
1	Check voltage between terminals HT1, HT2 of engine control module connector and body ground.
 <p>BE8653 F16890</p>	<p>P Connect SST (check harness "A"). See page EG-404 SST 09990-01000</p> <p>C Measure voltage between terminals HT1, HT2 of engine control module connector and body ground.</p> <p>OK Voltage: 9 — 14 V</p>
NG	OK Go to step 3 .

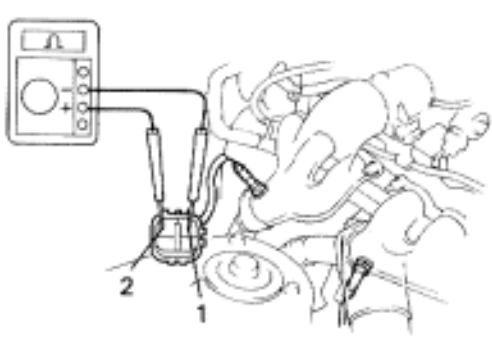
2	Check main heated oxygen sensor heater.
 <p>P11484</p>	<p>P Disconnect main heated oxygen sensor connector.</p> <p>C Measure resistance between terminals 1 and 2 of main heated oxygen sensor connector.</p> <p>OK Resistance: 11 — 16 Ω at 20°C (68°F)</p>
OK	NG Replace main heated oxygen sensor.

Check and repair harness or connector between main relay and main heated oxygen sensor, main heated oxygen sensor and engine control module.

3

Check voltage between terminals HT1, HT2 of engine control module connector and body ground.

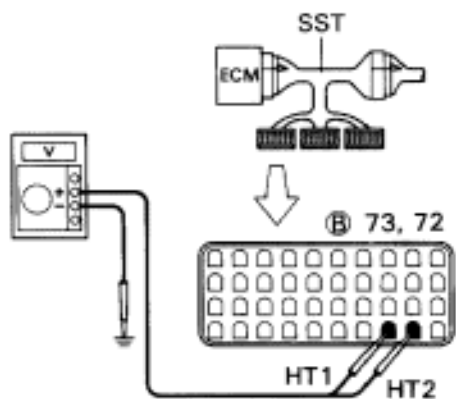

F16890

- P** Warm up engine to normal operating temperature.
- C** Measure voltage between terminals HT1, HT2 of engine control module connector and body ground when engine is idling and racing at 4,000 rpm.

OK

	Voltage
Idling	0 V
Racing at 4,000 rpm	9 - 14 V

Hint In the 4,000 rpm racing check, continue engine racing at 4,000 rpm for approx. 20 seconds or more.

NG

OK Replace main heated oxygen sensor.*

Check and replace engine control module.

*: It is probable the oxygen sensor has deteriorated. Usually, this cannot be confirmed by visual inspection.

Reference

INSPECTION USING OSCILLOSCOPE

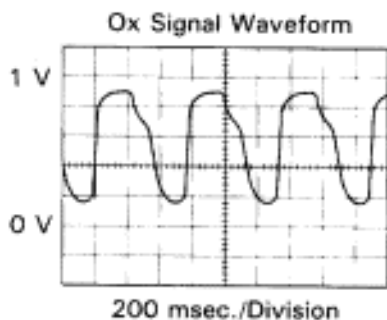

- With the engine racing (4,000 rpm) measure waveform between terminals OX1, OX2 and E1 of engine control module.

HINT: The correct waveform is as shown, oscillating between approx. 0.1 V and 0.9 V

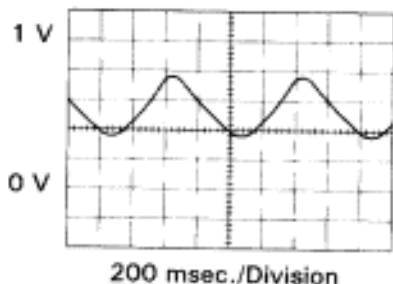

If the oxygen sensor has deteriorated, the amplitude of the voltage will be reduced as shown on the left.

F16514
F16515

DTC 22 Engine Coolant Temp. Sensor Circuit

CIRCUIT DESCRIPTION

The engine coolant temperature sensor senses the coolant temperature. A thermistor built in the sensor changes its resistance value according to the coolant temperature. The lower the coolant temperature, the greater the thermistor resistance value, and the higher the coolant temperature, the lower thermistor resistance value (See Fig. 1.).

The engine coolant temperature sensor is connected to the ECM (See wiring diagram). The 5 V power source voltage in the ECM is applied to the engine coolant temperature sensor from the terminal THW via a resistor R. That is, the resistor R and the engine coolant temperature sensor are connected in series. When the resistance value of the engine coolant temperature sensor changes in accordance with the changes in the coolant temperature the potential at the terminal THW also changes. Based on this signal, the ECM increases the fuel injection volume to improve driveability during cold engine operation. If the ECM detects the diagnostic trouble code 22, it operates the fail safe function in which the engine coolant temperature is assumed to be 80°C (176°F).

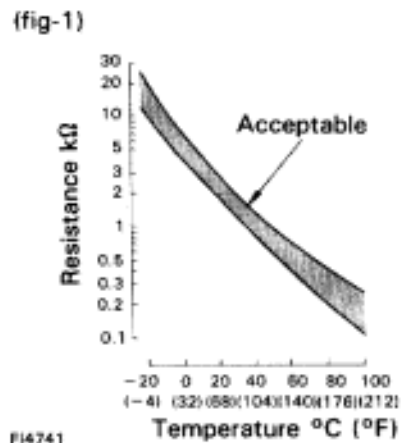

Reference

Engine Coolant Temp. °C (°F)	Resistance (kΩ)	Voltage (V)
-20 (-4)	16.2	4.3
0 (32)	5.9	3.4
20 (68)	2.5	2.4
40 (104)	1.1	1.4
60 (140)	0.6	0.9
80 (176)	0.3	0.5
100 (212)	0.2	0.3

DTC No.	Diagnostic Trouble Code Detecting Condition	Trouble Area
22	Open or short in engine coolant temp. sensor circuit for 0.5 sec. or more	<ul style="list-style-type: none"> Open or short in engine coolant temp. sensor circuit Engine coolant temp. sensor ECM

WIRING DIAGRAM

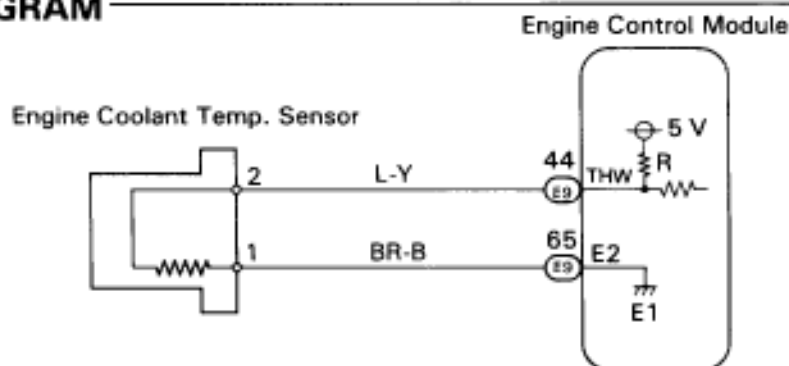

INSPECTION PROCEDURE

HINT: If diagnostic trouble codes "22" (engine coolant temperature sensor circuit), "24" (intake air temperature sensor circuit) and "41" (throttle position sensor circuit) are output simultaneously, E2 (sensor ground) may be open.

1

Check voltage between terminals THW and E2 of engine control module connector.

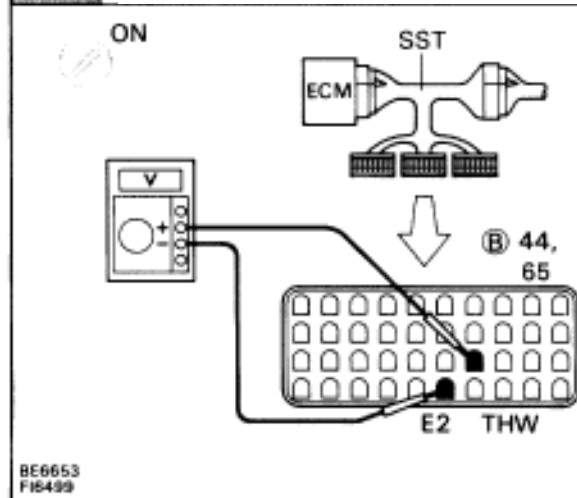

- P** (1) Connect SST (check harness "A").
(See page [EG-404](#))
(2) Turn ignition switch ON.

C Measure voltage between terminals THW and E2 of engine control module connector.

Engine Coolant Temp. °C (°F)	Voltage
20 (68) (Engine is cool)	0.5 - 3.4 V
80 (176) (Engine is hot)	0.2 - 1.0 V

NG

OK Check for intermittent problems.
(See page [EG-399](#))

2

Check engine coolant temp. sensor.

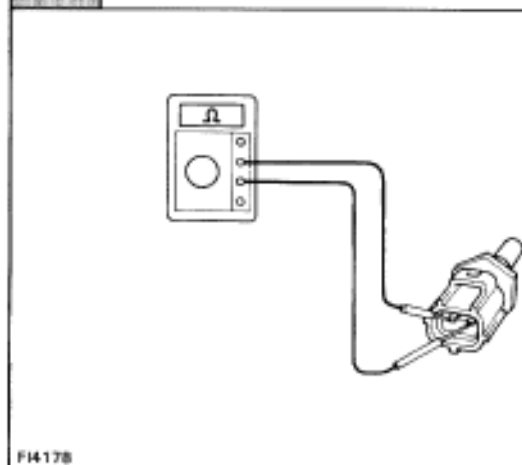

P Disconnect the engine coolant temp. sensor connector.

C Measure voltage between terminals.

OK Resistance is within Acceptable Zone on chart.

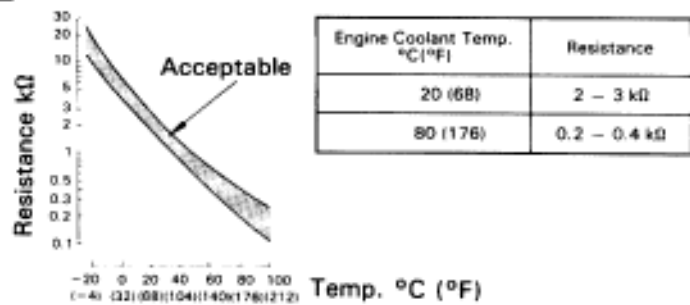

OK

NG Replace engine coolant temp. sensor.

3

Check for open and short in harness and connector between engine control module and engine coolant temp. sensor (see page [IN-30](#)).

OK

NG Repair or replace harness or connector.

Check and replace engine control module.

DTC 24 Intake Air Temp. Sensor Circuit

CIRCUIT DESCRIPTION

The intake air temp. sensor is built into the volume air flow meter and senses the intake air temperature. The structure of the sensor and connection to the ECM is the same as in the engine coolant temp. sensor shown on page EG-424.

If the ECM detects the diagnostic trouble code "24", it operates the fail safe function in which the intake air temperature is assumed to be 20°C (68°F).

DTC No.	Diagnostic Trouble Code Detecting Condition	Trouble Area
24	Open or short in intake air temp. sensor circuit for 0.5 sec. or more	<ul style="list-style-type: none"> • Open or short in intake air temp. sensor circuit • Intake air temp. sensor • ECM

WIRING DIAGRAM

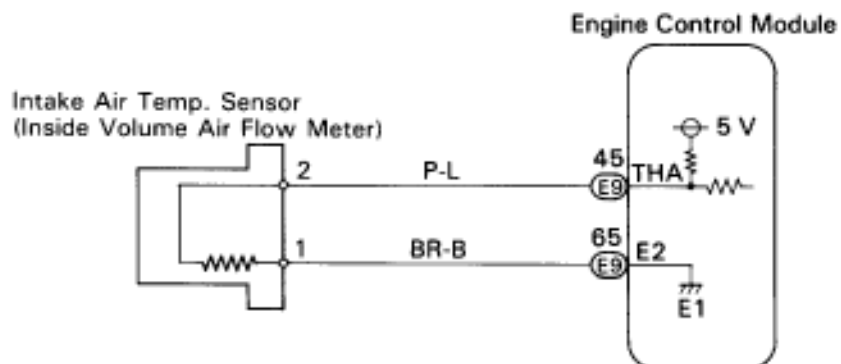

FIG44B

INSPECTION PROCEDURE

HINT: If diagnostic trouble codes "22" (engine coolant temperature sensor circuit), "24" (intake air temperature sensor circuit) and "41" (throttle position sensor circuit) are output simultaneously, E2 (sensor ground) may be open.

1 Check voltage between terminals THA and E2 of engine control module connector.

P (1) Connect SST (check harness "A").
(See page EG-404)
SST 09990-01000
(2) Turn ignition switch ON.

C Measure voltage between terminals THW and E2 of engine control module connector.

OK

Intake air temp. °C (°F)	Voltage
20 (68)	0.5 - 3.4 V
60 (140)	0.2 - 1.0 V

NG

OK Check for intermittent problems.
(See page EG-399)

2 Check intake air temp. sensor.

P Disconnect the volume air flow meter connector.

C Measure voltage between terminals 1 and 2 of volume air flow meter connector.

OK Resistance is within Acceptable Zone on chart.

Intake air temp. °C (°F)	Resistance
20 (68)	2 - 3 kΩ
60 (14)	0.4 - 0.7 kΩ

OK

NG Replace intake air temp. sensor (Replace volume air flow meter).

3 Check for open and short in harness and connector between engine control module and intake air temp. sensor (See page IN-30).

OK

NG Repair or replace harness or connector.

Check and replace engine control module.

DTC 25 26 Air-Fuel Ratio Lean Rich Malfunction

CIRCUIT DESCRIPTION

See page [EG-419](#) for the circuit description

DTC No.	Diagnostic Trouble Code Detecting Condition	Trouble Area
25	(1) (Main heated*1) oxygen sensor voltage is 0.45 V or less (lean) for 90 sec. under conditions (a) and (b): (2 trip detection logic)*2 (a) Engine coolant temp.: 70°C (158°F) or more (b) Engine speed: 1,500 rpm or more	<ul style="list-style-type: none"> • Open or short in (main heated*1) oxygen sensor circuit • (Main heated*1) oxygen sensor • Ignition system • ECM
	(2)*1 Difference of air-fuel ratio feedback compensation value between front (No. 1 ~ 3 cylinders) and rear (No. 4 ~ 6 cylinders) is more than 15 percentage for 20 sec. or more under conditions (a) and (b): (2 trip detection logic)*2 (a) Engine speed: 2,000 rpm or more (b) Engine coolant temp.: Between 60°C (140°F) and 95°C (203°F)	<ul style="list-style-type: none"> • Open and short in injector circuit • Fuel line pressure (injector leak, blockage) • Mechanical system malfunction (skipping teeth of timing belt) • Ignition system • Compression pressure (foreign object caught in valve) • Volume air flow meter (air intake) • ECM
	(3)*1 Engine speed varies by more than 15 rpm over the preceding crank angle period during a period of 20 sec. or more under conditions (a) and (b): (2 trip detection logic)*2 (a) Engine speed: Idling (b) Engine coolant temp.: Between 60°C (140°F) and 95°C (203°F)	<ul style="list-style-type: none"> • Open and short in injector circuit • Fuel line pressure (injector leak, blockage) • Mechanical system malfunction (skipping teeth of timing belt) • Ignition system • Compression pressure (foreign object caught in valve) • Volume air flow meter (air intake) • ECM
26	(1)*1 Difference of air-fuel ratio feedback compensation value between front (No. 1 ~ 3 cylinders) and rear (No. 4 ~ 6 cylinders) is more than 15 percentage for 20 sec. or more under conditions (a) and (b): (2 trip detection logic)*2 (a) Engine speed: 2,000 rpm or more (b) Engine coolant temp.: Between 60°C (140°F) and 95°C (203°F)	<ul style="list-style-type: none"> • Open and short in injector circuit • Fuel line pressure (injector leak, blockage) • Mechanical system malfunction (skipping teeth of timing belt) • Ignition system • Compression pressure (foreign object caught in valve) • Volume air flow meter (air intake) • ECM
	(2) Engine speed varies by more than 15 rpm over the preceding crank angle period during a period of 20 sec. or more under conditions (a) and (b): (2 trip detection logic)*2 (a) Engine speed: Idling (b) Engine coolant temp.: Between 60°C (140°F) and 95°C (203°F)	<ul style="list-style-type: none"> • Open and short in injector circuit • Fuel line pressure (injector leak, blockage) • Mechanical system malfunction (skipping teeth of timing belt) • Ignition system • Compression pressure (foreign object caught in valve) • Volume air flow meter (air intake) • ECM

*1: Only for California specification vehicles

*2: See page [EG-397](#).

CIRCUIT DESCRIPTION (Cont'd)**DIAGNOSTIC TROUBLE CODE DETECTION DRIVING PATTERN**

Purpose of the driving pattern.

- (a) To simulate diagnostic trouble code detecting condition after diagnostic trouble code is recorded.
- (b) To check that the malfunction is corrected when the repair is completed confirming that diagnostic trouble code is no longer detected.

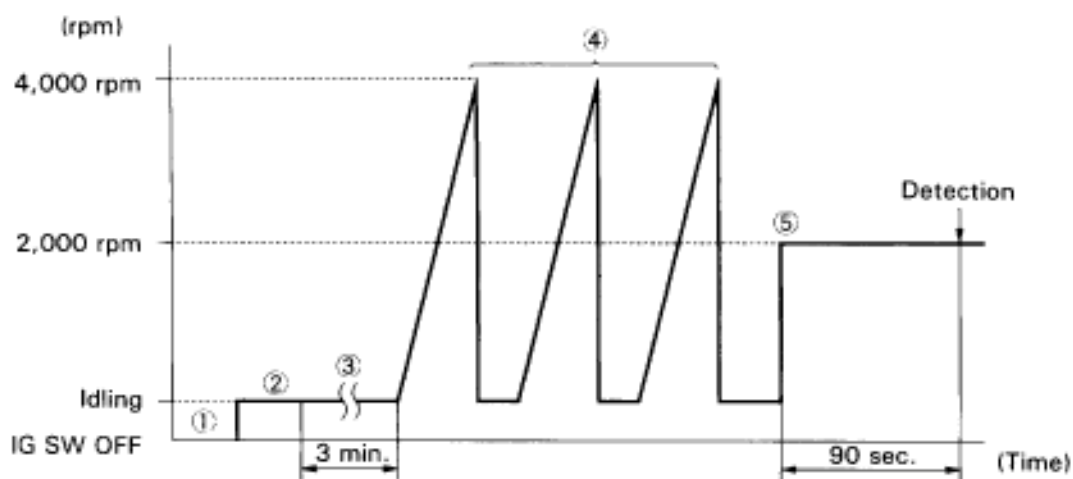
Malfunction: Open or Short in (Main Heated*) Oxygen Sensor

F16465

HINT: Before this test, check the feedback voltage for oxygen sensor.

- (1) Disconnect the EFI No.1 fuse (30 A) for 10 sec. or more, with IG switch OFF. Initiate test mode (Connect terminal TE2 and E1 of data link connector 2 with IG switch OFF).
- (2) Start the engine and warm up.
- (3) Idle the engine for 3 min.
- (4) Race the engine at 2,000 rpm for 90 sec.

HINT: If a malfunction exists, the malfunction indicator lamp will light up during step (4).

NOTICE: If the conditions in this test are not strictly followed, detection of the malfunction will not be possible.

*: Only for California specification vehicles

CIRCUIT DESCRIPTION (Cont'd)**DIAGNOSTIC TROUBLE CODE DETECTION DRIVING PATTERN**

Purpose of the driving pattern.

- To simulate diagnostic trouble code detecting condition after diagnostic trouble code is recorded.
- To check that the malfunction is corrected when the repair is completed confirming that diagnostic trouble code is no longer detected.

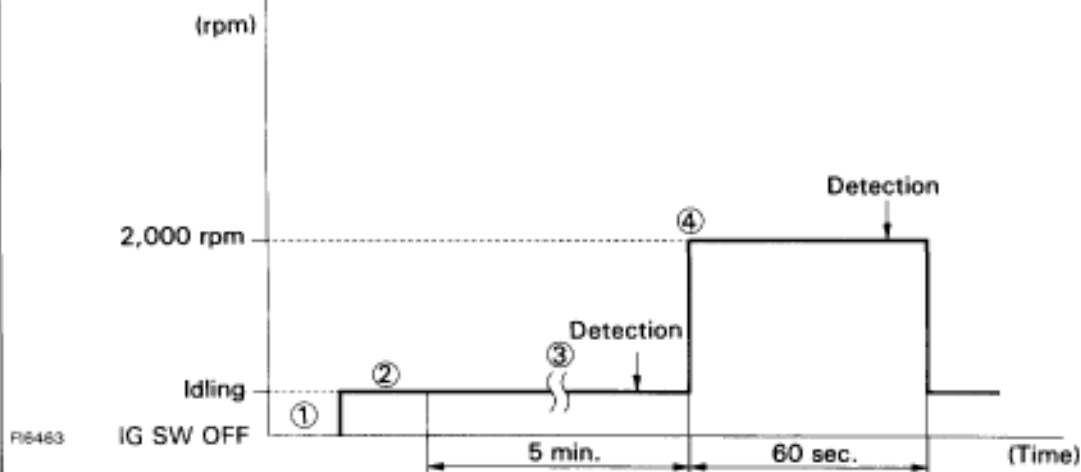
Malfunction: Open or Short in Injector circuit, Injector Leak or Blockage.

- Disconnect the EFI No.1 fuse (30A) for 10 sec. or more, with IG switch OFF. Initiate test mode (Connect terminal TE2 and E1 of data link connector 2 with IG switch OFF).
- Start the engine and warm up with all ACC switched OFF.
- Idle the engine for 5 min.
(After the engine is started, do not depress the accelerator pedal.)
- If the malfunction is not detected during idling, racing the engine without any load at approx. 2,000 rpm for 60 sec.

HINT: If a malfunction exists, the malfunction indicator lamp will light up during the 5 min. idling period or within 60 sec. of starting racing.

NOTICE: If the conditions in this test are not strictly followed, detection of the malfunction will not be possible.

WIRING DIAGRAM

See page **EG-421** for the WIRING DIAGRAM.

*: Only for California specification vehicles

INSPECTION PROCEDURE

1 Check voltage between terminals VF1, VF2 and E1 of data link connector 1.

Front Side

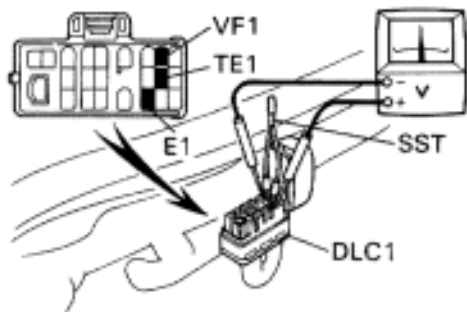

Rear Side

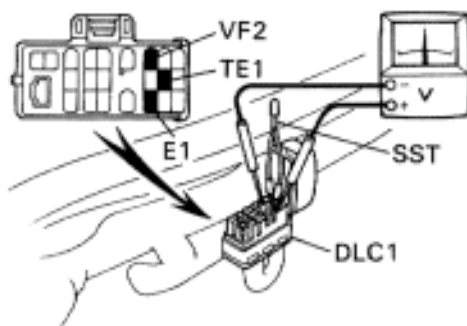

P11292
P11293

- P**
- Warm up engine to normal operating temperature.
 - Using SST, connect terminal TE1 and E1 of data link connector 1.
SST 09843-18020
 - Connect positive probe to terminal VF1, VF2 and negative probe to terminal E1 of data link connector 1.

- C**
- Warm up the oxygen sensor by racing engine at 2,500 rpm for about 2 minutes.
 - Then, still maintaining engine at 2,500 rpm, count how many times voltmeter fluctuates needle between 0 and 5 V.

Result

Result	
Needle fluctuates 8 times or more for every ten seconds	OK
Continue at 0 V	NG Type I
Continue at 5 V	NG Type II

NG
Type I

NG
Type II Go to step **7**.

2 Check voltage between terminals OX1, OX2 and E1 of data link connector 1.

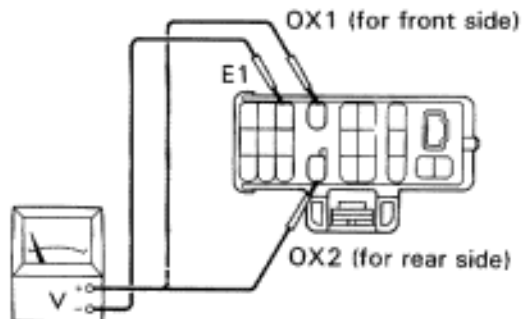

F18595

- P** Warm up engine to normal operating temperature
- C** Measure voltage between terminals OX1, OX2 and E1 of data link connector 1 when engine is suddenly raced to full throttle.
- OK** The voltage should be 0.5 V or higher at least once.
- Hint** Inspection should not take longer 1 second.

NG

OK Go to step **7**.

3

Check for open and short in harness and connector between engine control module and (main heated*) oxygen sensor, engine control module and data link connector 1 (see page [IN-30](#)).

OK**NG**

Repair or replace harness or connector.

4

Check each item found to be a possible cause of problem.

Check each circuit found to be a possible cause of trouble according to the results of the check in **1** or **2**. The numbers in the table below show the order in which the checks should be done.

(Main heated*) oxygen sensor signal from either side continues at 0 V	(Main heated*) oxygen sensor signal from both sides continues at 0 V	Possible Cause	See page
1		Faulty sensor installation	-
3		Injector circuit	EG-47
2	3	Misfire	IG-4
4		Valve timing	EG-33
	1	Air leakage	EG-190
	2	Fuel system	EG-457
	6	Characteristics deviation in volume air flow meter	EG-438
	4	Characteristics deviation in engine coolant temp. sensor	EG-424
	5	Characteristics deviation in intake air temp. sensor	EG-426

OK**NG**

Repair or replace.

5

Check compression (See page [EG-9](#)).

OK**NG**

Repair or replace.

6

Does malfunction disappear when a good (main heated*) oxygen sensor is installed?

NG**YES**

Replace (main heated*) oxygen sensor.

Check and replace engine control module.

*: Only for California specification vehicles

7**Check each item found to be a possible cause of problem.**

Check each circuit found to be a possible cause of trouble according to the results of the check in **1**. The numbers in the table below show the order in which the checks should be done.

(Main heated*) oxygen sensor signal from either side continues at 5.0 V	(Main heated*) oxygen sensor signal from both sides continues at 5.0 V	(Main heated*) oxygen sensor signals from both sides are normal	Possible Cause	See page
1		7	Injector circuit	EG-4
		3	Misfire	IG-4
2		4	Valve timing	EG-33
		1	Air leakage	EG-19
	1	2	Fuel system	EG-457
	4	8	Characteristics deviation in volume air flow meter	EG-438
	2	5	Characteristics deviation engine coolant temp. sensor	EG-424
	3	6	Characteristics deviation in intake air temp. sensor	EG-426

OK**NG**

Repair or replace.

8**Check compression (See page EG-9).****OK****NG**

Repair or replace.

9**Does malfunction disappear when a good (main heated*) oxygen sensor is installed?****NG****YES**

Replace (main heated*) oxygen sensor.

Check and replace engine control module.

*: Only for California specification vehicles

DTC 27 Sub Heated Oxygen Sensor Circuit (Only for California spec.)

CIRCUIT DESCRIPTION

The sub heated oxygen sensor is installed on the exhaust pipe. Its construction and operation is the same as the main heated oxygen sensor on page [EG-419](#).

DTC No.	Diagnostic Trouble Code Detecting Condition	Trouble Area
27	(1) Open or short in heater circuit of sub heated oxygen sensor for 0.5 sec. or more	<ul style="list-style-type: none"> • Open or short in heater circuit of sub heated oxygen sensor • Sub heated oxygen sensor heater • ECM
	(2) Main heated oxygen sensor signal is 0.45 V or more and sub heated oxygen sensor signal is 0.45 V or less under conditions (a) ~ (c): (2 trip detection logic)* (a) Engine coolant temp.: 80°C (176°F) or more (b) Engine speed: 1,500 rpm or more (c) Accel. pedal: Fully depressed for 2 sec. or more	<ul style="list-style-type: none"> • Open or short in sub heated oxygen sensor circuit • Sub heated oxygen sensor • ECM

*: See page [EG-397](#).

CIRCUIT DESCRIPTION (Cont'd)**DIAGNOSTIC TROUBLE CODE DETECTION DRIVING PATTERN**

Purpose of the driving pattern.

- (a) To simulate diagnostic trouble code detecting condition after diagnostic trouble code is recorded.
- (b) To check that the malfunction is corrected when the repair is completed confirming that diagnostic trouble code is no longer detected.

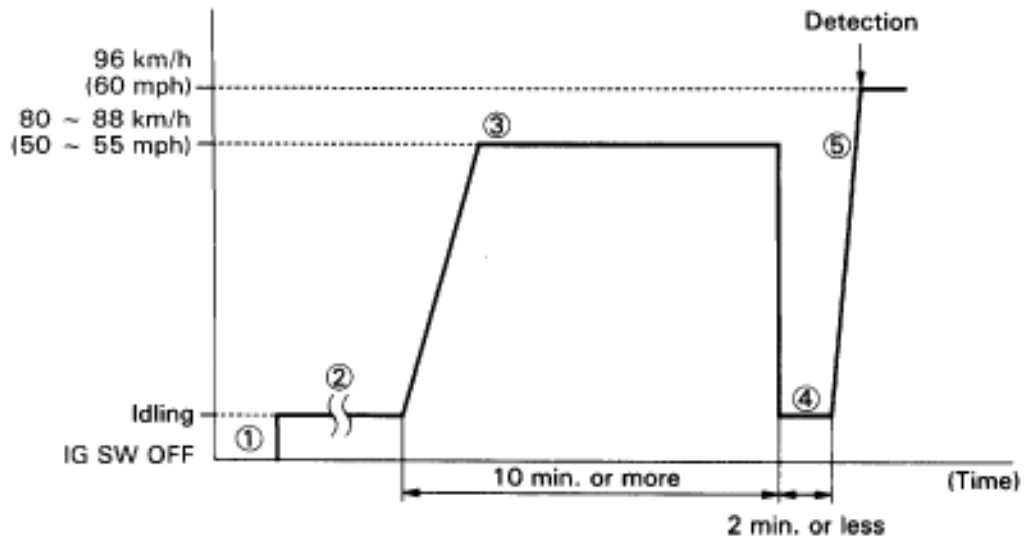
Malfunction: Open or Short in Sub Heated Oxygen Sensor

FM5527

- (1) Disconnect the EFI No.1 fuse (30A) for 10 sec. or more, with IG switch OFF. Initiate test mode (Connect terminal TE2 and E1 of data link connector 2 with IG switch OFF).
- (2) Start the engine and warm up with all ACC switch OFF.
- (3) Drive the vehicle at 80 ~ 88 km/h (50 ~ 55 mph) for 10 min. or more.
- (4) Stop at a safe place and idle the engine for 2 min. or less.
- (5) Accelerate to 96 km/h (60 mph) with the throttle valve fully open.

HINT: If a malfunction exists, the malfunction indicator lamp will light up during step (5).

NOTICE: If the conditions in this test are not strictly followed, detection of the malfunction will not be possible.

WIRING DIAGRAM

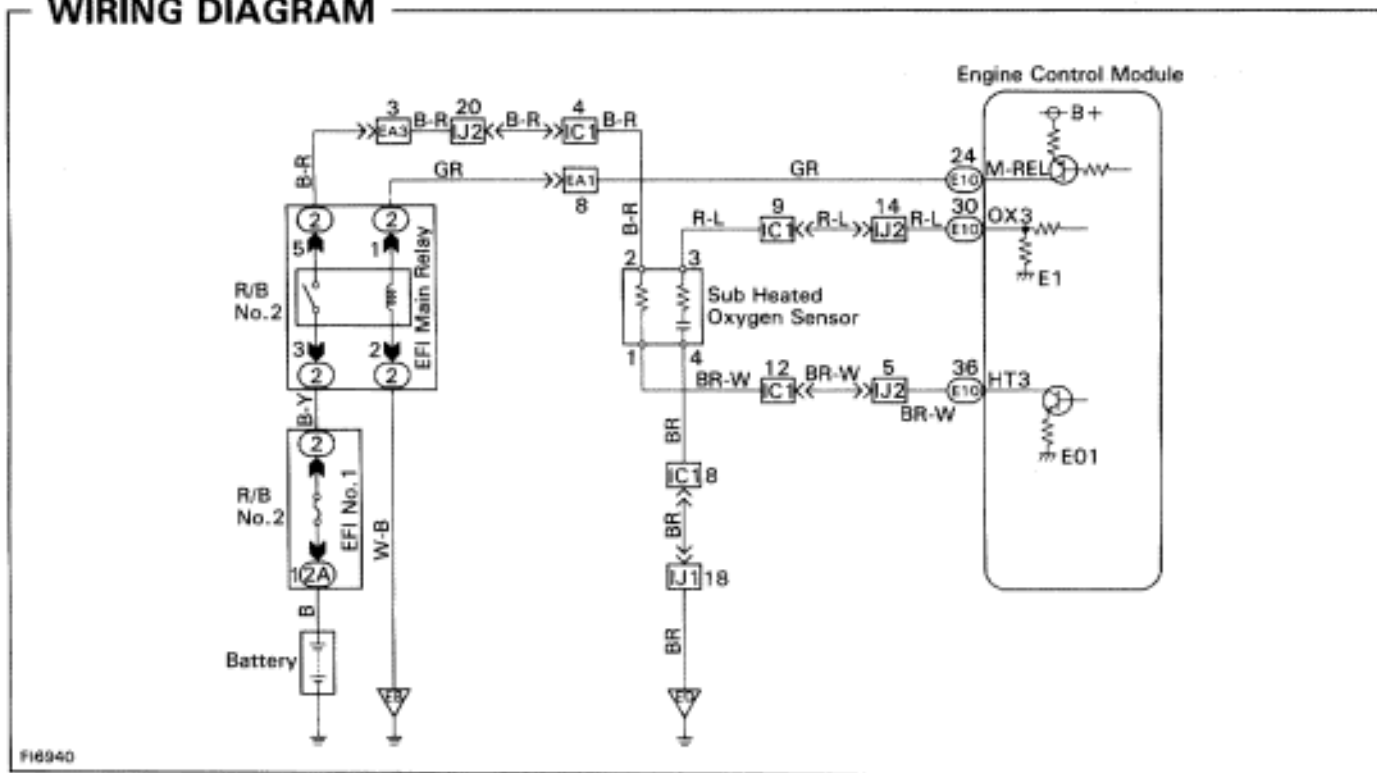

F16940

INSPECTION PROCEDURE

HINT: When other codes are output in addition to 27 at the same time, check the circuits for other codes first.

1	Check voltage between terminal HT3 of engine control module connector and body ground.
<p>ON</p> <p>BE6653 F16891</p>	<p>P (1) Connect SST (check harness "A"). (See page EG-404) SST 09990-01000 (2) Turn ignition switch ON.</p> <p>C Measure voltage between terminal HT3 of engine control module connector and body ground.</p> <p>OK Voltage: 9 — 14 V</p>
NG	OK Go to step 4 .

2 Check sub heated oxygen sensor heater.

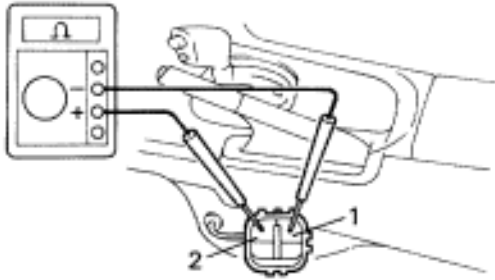

P11483

- P** Disconnect sub heated oxygen sensor connector. (See page EG-250)
- C** Measure resistance between terminals 1 and 2 of sub heated oxygen sensor connector.
- OK** Resistance: 11 — 16 Ω at 20°C (68°F)

OK

NG Replace sub heated oxygen sensor.

3 Check for open and short in harness and connector between EFI main relay and engine control module (See page IN-30).

OK

NG Repair or replace harness or connector.

Check and replace engine control module.

4 Check voltage between terminal HT3 of engine control module connector and body ground.

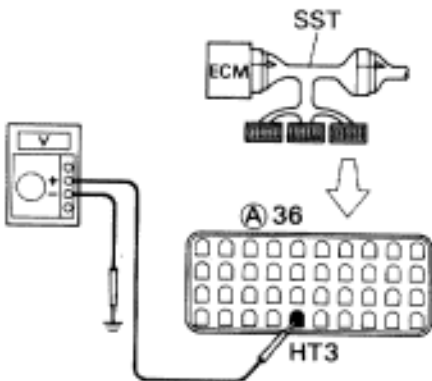

F16891

- P** Warm up engine to normal operating temperature.
- C** Measure voltage between terminal HT3 of engine control module connector and body ground, when engine is idling and racing at 3,500 rpm.

OK

	Voltage
Idling	0 V
Racing at 3,500 rpm	9 - 14 V

NG

OK Replace sub heated oxygen sensor.

Check and replace engine control module.

*: It is probable the oxygen sensor has deteriorated. Usually, this cannot be confirmed by visual inspection.

DTC 31 Volume Air Flow Meter Circuit

CIRCUIT DESCRIPTION

As shown in the figure at right, when a pillar (Vortex generating body) is placed in the path of a uniform flow, vortices called Karman-Vortex are generated downstream of the object. Using this principle, a vortex generator is placed inside the volume air flow meter. By measuring the frequency of the vortices generated, the ECM can determine the volume of air flowing through the volume air flow meter. The vortices are detected by their exerting pressure on thin metal foil mirror) surfaces and a light emitting element and light receptor (LED and photo transistor) positioned opposite the mirror which optically senses the vibrations in the mirror. The ECM uses these signals mainly for calculation of the basic injection volume and the basic ignition advance angle.

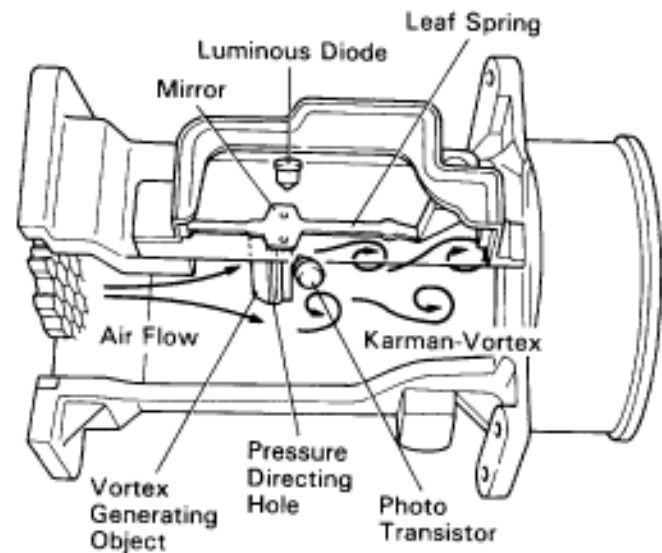

Karman-Vortex

DTC No.	Diagnostic Trouble Code Detecting Condition	Trouble Area
31	All conditions below are detected: (a) No volume air flow meter signal to ECM for 2 sec. when engine speed is above 300 rpm (b) Engine stall	<ul style="list-style-type: none"> • Open or short in volume air flow meter circuit • Volume air flow meter • ECM

If the ECM detects diagnostic trouble code "31", it operates the fail safe function, keeping the ignition timing and fuel injection volume constant and making it possible to drive the vehicle.

WIRING DIAGRAM

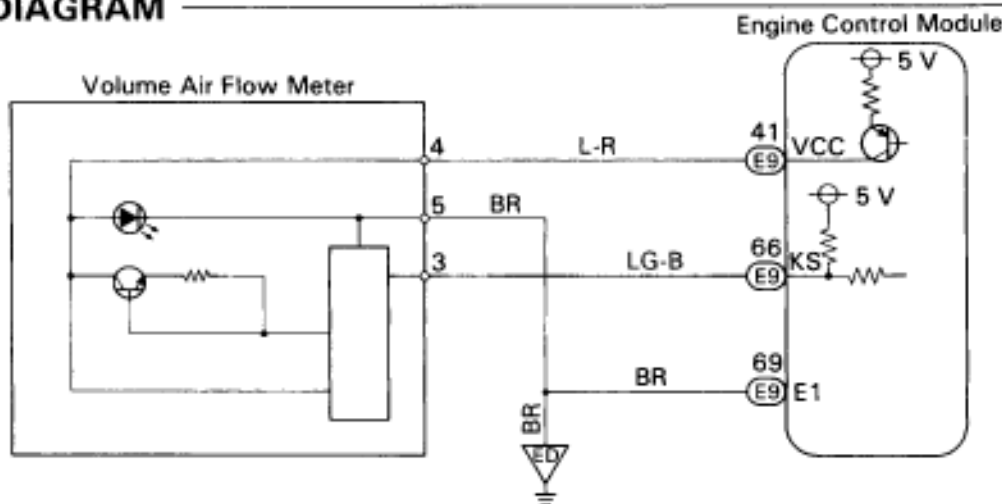

INSPECTION PROCEDURE

1

Check voltage between terminals KS and E1 of engine control module connector.

START

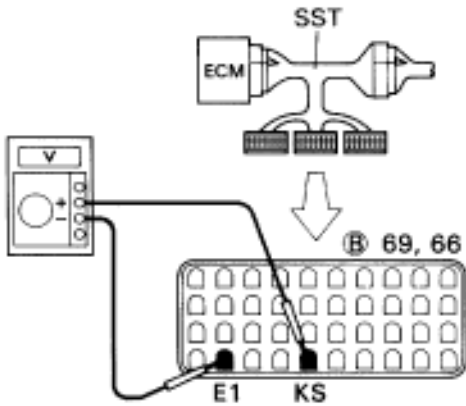
BE6653
F16502

P Connect SST (check harness "A").
(See page EG-404)
SST 09990-01000

C Measure voltage between terminals KS and E1 of engine control module connector while engine is cranked.

OK Voltage: 2.0 — 4.0 V
(Neither 0 V nor 5 V)

Reference

INSPECTION USING OSCILLOSCOPE

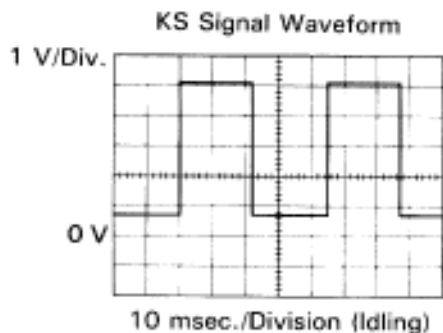

F16512

- During cranking or idling, measure waveform between terminals KS and E1 of engine control module.

HINT: The correct waveform is as shown.

NG

OK

When diagnostic trouble code 31 is displayed, check and replace engine control module.

2

Check for open and short in harness and connector between engine control module and volume air flow meter (See page IN-30).

OK

NG

Repair or replace harness or connector.

3**Disconnect volume air flow meter connector and check voltage between terminals KS and E1 of engine control module connector.**

ON

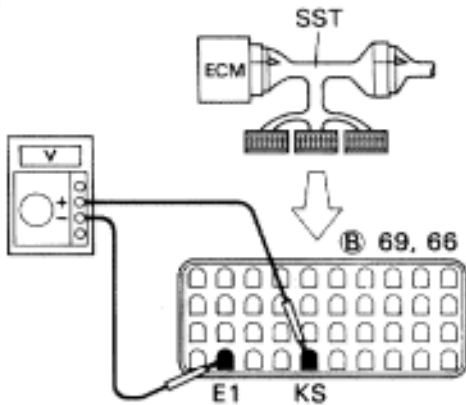
BE6653
F16502

- P** (1) Disconnect the volume air flow meter connector.
(2) Turn ignition switch ON.

C Measure voltage between terminals KS and E1 of engine control module connector.

OK Voltage: 4.5 — 5.5 V

OK

NG

Check and replace engine control module.

4**Disconnect volume air flow meter connector and check voltage between terminals VCC and E1 of engine control module connector.**

ON

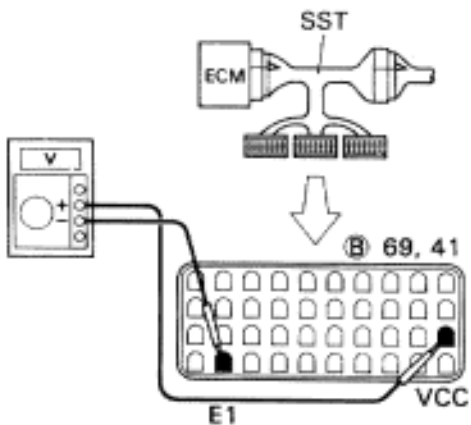
BE6653
F16506

- P** (1) Disconnect the volume air flow meter connector.
(2) Turn ignition switch ON.

C Measure voltage between terminals VCC and E1 of engine control module connector.

OK Voltage: 4.5 — 5.5 V

NG

OK

Replace volume air flow meter.

Check and replace engine control module.

DTC 35 Barometric Pressure Sensor Circuit

CIRCUIT DESCRIPTION

The BARO sensor is built into the ECM. This is a semiconductor pressure sensor with properties which cause its electrical resistance to change when stress is applied to the sensor's crystal (silicon) (piezoelectric effect). This sensor is used to detect the atmospheric (absolute) pressure and outputs corresponding electrical signals. Fluctuations in the air pressure cause changes in the intake air density, which can cause deviations in the air-fuel ratio. The signals from BARO sensor are used to make corrections for these fluctuations. If the ECM detects diagnostic trouble code "35", the fail safe function operates and the atmospheric pressure is set at a constant 101.3 kPa (760 mmHg, 29.92 in.Hg).

DTC No.	Diagnostic Trouble Code Detecting Condition	Trouble Area
35	Open or short in BARO sensor circuit for 0.5 sec. or more	• ECM

INSPECTION PROCEDURE

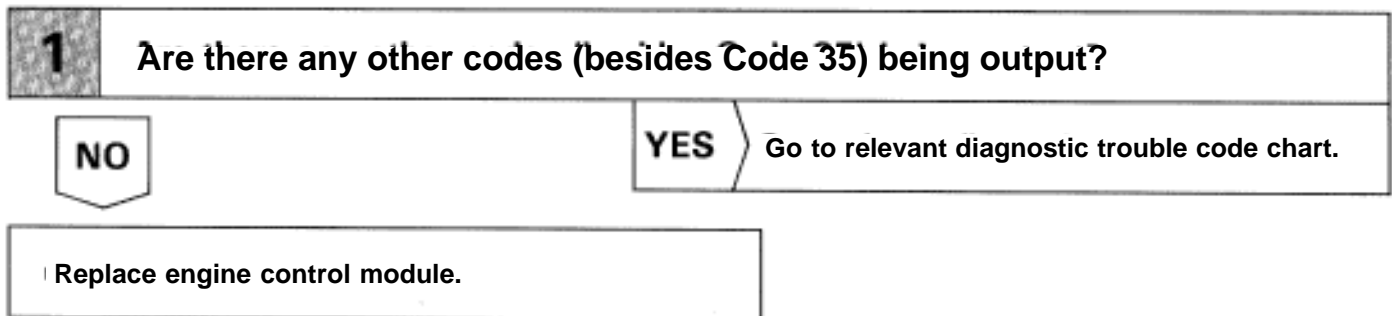

DTC 41 Throttle Position Sensor Circuit

CIRCUIT DESCRIPTION

The throttle position sensor is mounted in the throttle body and detects the throttle valve opening angle. When the throttle valve is fully closed, the IDL contacts in the throttle position sensor are on, so the voltage at the terminal IDL of the ECM becomes 0 V. At this time, a voltage of approximately 0.7 V is applied to the terminal VTA of the ECM. When the throttle valve is opened, the IDL contacts go off and thus the power source voltage of approximately 12 V in the ECM is applied to the terminal IDL of the ECM. The voltage applied to the terminal VTA of the ECM increases in the proportion to the opening angle of the throttle valve and becomes approximately 3.2 – 4.9 V when the throttle valve is fully opened. The ECM judges the vehicles driving conditions from these signals input from the terminals VTA and IDL, and uses them as one of the conditions for deciding the air-fuel ratio correction, power increase correction and fuel-cut control etc.

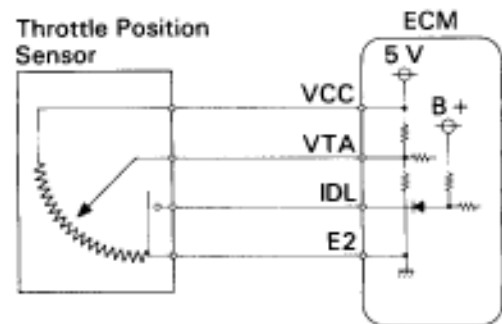

F16571

DTC No.	Diagnostic Trouble Code Detecting Condition	Trouble Area
41	Open or short in throttle position sensor circuit for 0.5 sec. or more	<ul style="list-style-type: none"> • Open or short in throttle position sensor circuit • Throttle position sensor • ECM

HINT:

- When the connector for the throttle position sensor is disconnected, diagnostic trouble code 41 is not displayed. Diagnostic trouble code 41 is displayed only when there is an open or short in the VTA signal circuit of the throttle position sensor.

WIRING DIAGRAM

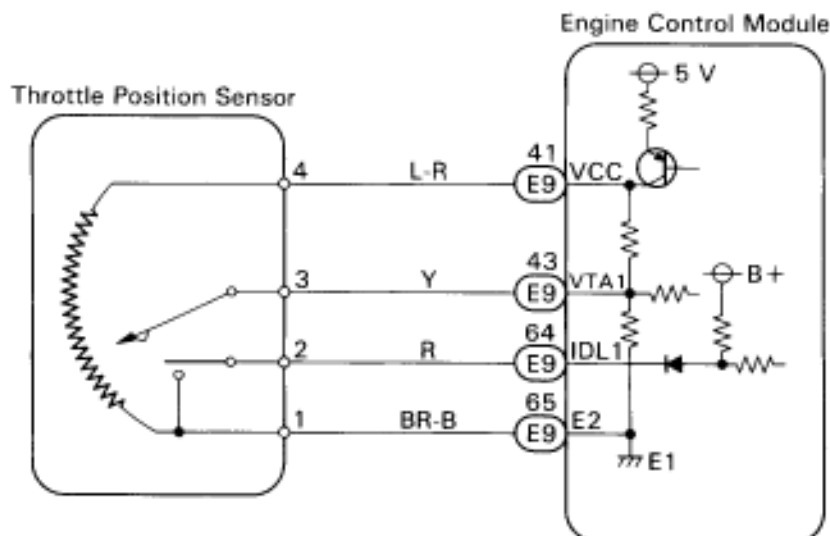

F16941

INSPECTION PROCEDURE

HINT:

- If diagnostic trouble code "22" (engine coolant temperature sensor circuit), "24" (intake air temperature sensor circuit) and "41" (throttle position sensor circuit) are output simultaneously, E2 (sensor ground) may be open.

1 Check voltage between VTA1, IDL1 and E2 of engine control module connector.

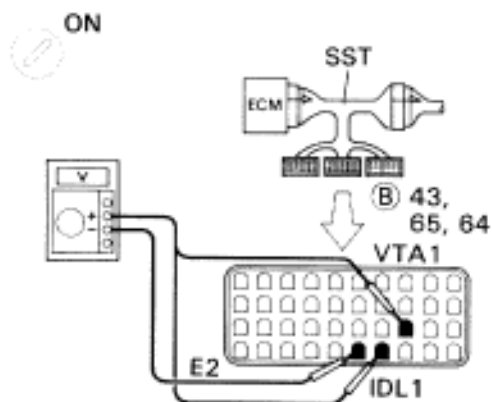

- P** (1) Connect SST (check harness "A").
(See page EG-404)
SST 09990-01000
(2) Turn ignition switch ON.
(3) Disconnect the vacuum hose from the throttle body, then apply vacuum to the throttle opener.
(See page EG-219)

C Measure voltage between terminals VTA1, IDL1 and E2 of engine control module connector when the throttle valve is opened gradually from the closed condition.

OK

Terminal	VTA1 - E2	IDL1 - E2
Throttle Valve		
Fully Closed	0.3 - 0.8 V	0 - 3.0 V
Fully Open	3.2 - 4.9 V	9 - 14 V

Hint The voltage should increase steadily in proportion to the throttle valve opening angle.

BE6653
F16911

NG

OK Check for intermittent problems.
(See page EG-399)

2

Check throttle position sensor

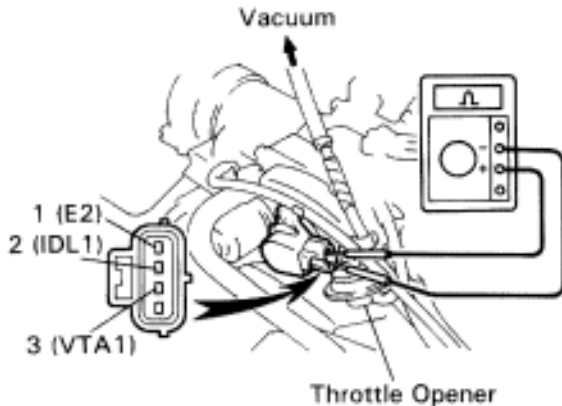

P11462

- P** (1) Disconnect throttle position sensor connector.
 (2) Disconnect the vacuum hose from the throttle body, then apply vacuum to the throttle opener. (See page [EG-219](#))

- C** Measure resistance between terminals 3 (VTA1), 2 (IDL1) and 1 (E2) of throttle position sensor connector when the throttle valve is opened gradually from the closed condition.

OK

Terminal	3 (VTA1) – 1 (E2)	2 (IDL1) – 1 (E2)
Throttle Valve		
Fully Closed	0.3 – 6.3 kΩ	Less than 0.5 kΩ
Fully Open	2.4 – 11.2 kΩ	1 MΩ or higher

Hint

Resistance between terminals 3 (VTA1) and 1 (E2) should increase gradually in accordance with the throttle valve opening angle.

OK**NG**

Adjust or replace throttle position sensor.
 (see page [EG-223](#))

3

Check for open and short in harness and connector between engine control module and throttle position sensor (See page [IN30](#)).**OK****NG**

Repair or replace harness or connector.

Check and replace engine control module.

DTC 42 No.1 Vehicle Speed Sensor Signal Circuit

CIRCUIT DESCRIPTION

The No.1 vehicle speed sensor outputs a 4-pulse signal for every revolution of the rotor shaft, which is rotated by the transmission output shaft via the driven gear. After this signal is converted into a more precise rectangular waveform by the waveform shaping circuit inside the odometer and trip meter, it is then transmitted to the engine control module. The ECM determines the vehicle speed based on the frequency of these pulse signals.

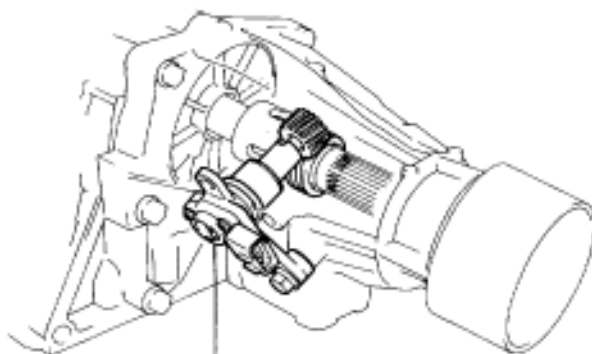
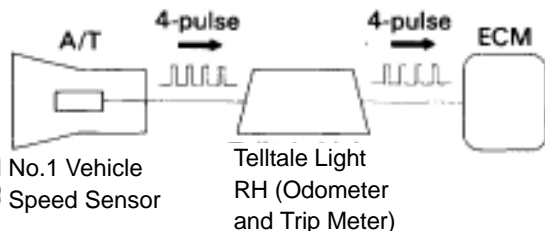

No.1 Vehicle Speed Sensor

F16643 F16644

DTC No.	Diagnostic Trouble Code Detecting Condition	Trouble Area
42	For A/T All conditions below are detected continuously for 8 sec. or more: (a) No.1 vehicle speed signal: 0 km/h (mph) (b) Engine speed: 3,000 rpm or more (c) Park/neutral position switch: OFF (d) Stop light switch: OFF	<ul style="list-style-type: none"> No.1 Vehicle speed sensor Telltale light RH (Odometer and trip meter) Open or short in No.1 vehicle speed sensor circuit ECM
	For A/T All conditions below are detected continuously for 8 sec. or more: (a) No.1 vehicle speed signal: 0 km/h (mph) (b) Engine speed: Between 2,000 rpm and 5,000 rpm (c) Engine coolant temp.: 80°C (176°F) or more (d) Load driving	

HINT: In test mode, diagnostic trouble code 42 is output when vehicle speed is 5 km/h (3 mph) or below.

Reference

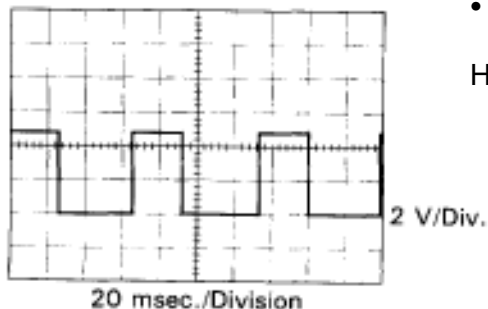

- Waveform between terminals SP1 and E1 when vehicle speed is approx. 20 km/h (12mph).

HINT: As the vehicle speed increases, the number of signals from SP1 increases.

WIRING DIAGRAM

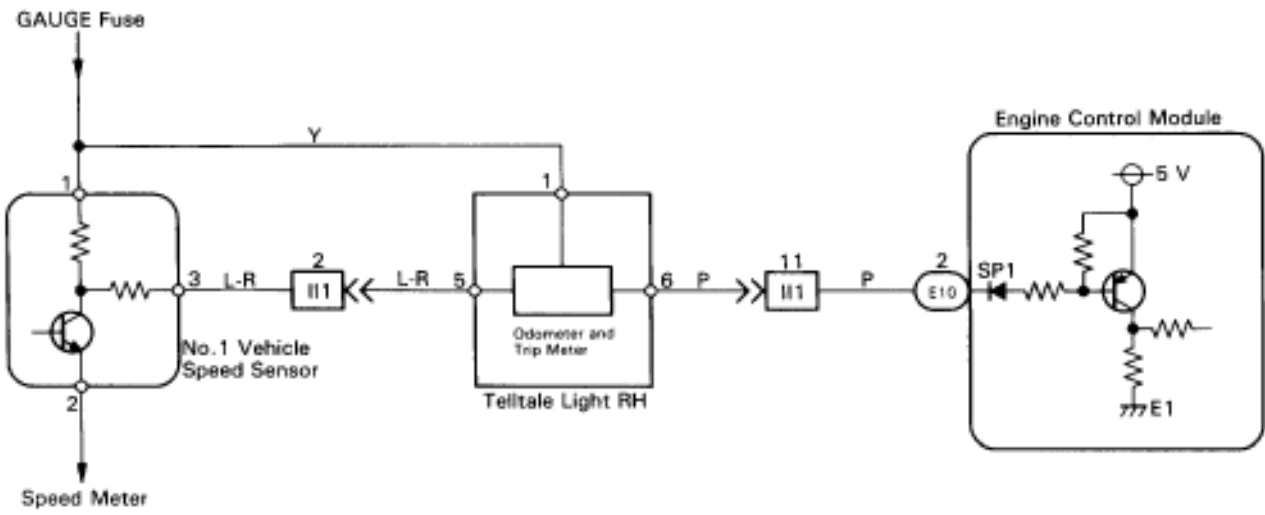

F16931

INSPECTION PROCEDURE

1

Check voltage between terminal SP1 of engine control module connector and body ground.

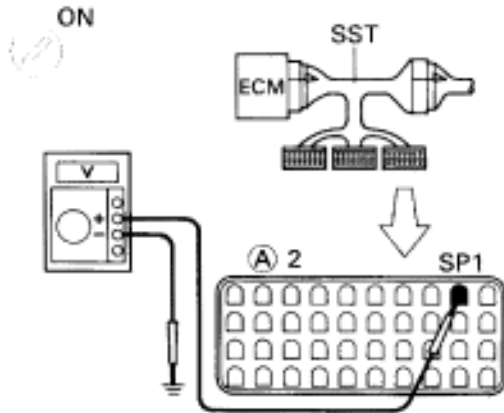
BE8653
F16504**P**

- (1) Shift the shift lever to N position.
- (2) Jack up one of the rear wheel.
- (3) Connect SST (check harness "A").
(See page EG-404)

SST 09990-01000

- (4) Disconnect power steering ECU connector and cruise control ECU connector.
- (5) Turn ignition switch ON.

C

Measure voltage between terminal SP1 of engine control module connector and body ground when the wheel is turned slowly.

OK

Voltage is generated intermittently.

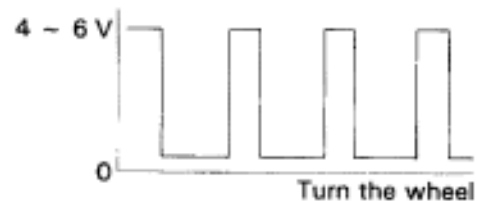

AT7809

NG**OK**

Check and replace engine control module.

2

Check operation of odometer and trip meter (telltale light RH (See page BE-48)).

NG**OK**

Repair or replace harness or connector between ECM and telltale light RH.

3

Check operation of No.1 vehicle speed sensor (See page BE-46).

NG**OK**

Repair or replace harness or connector between telltale light RH and No.1 vehicle speed sensor.

Replace No.1 vehicle speed sensor.

DTC 43 Starter Signal Circuit

CIRCUIT DESCRIPTION

When the engine is being cranked, the intake air flow is slow, so fuel vaporization is poor. A rich mixture is therefore necessary in order to achieve good startability. While the engine is being cranked, the battery positive voltage is applied to terminal STA of the ECM. The starter signal is mainly used to increase the fuel injection volume for the starting injection control and after-start injection control.

DTC No.	Diagnostic Trouble Code Detecting Condition	Trouble Area
43	No starter signal to ECM	<ul style="list-style-type: none"> • Open or short in starter signal circuit • Open or short in ignition switch or starter relay circuit • ECM

WIRING DIAGRAM

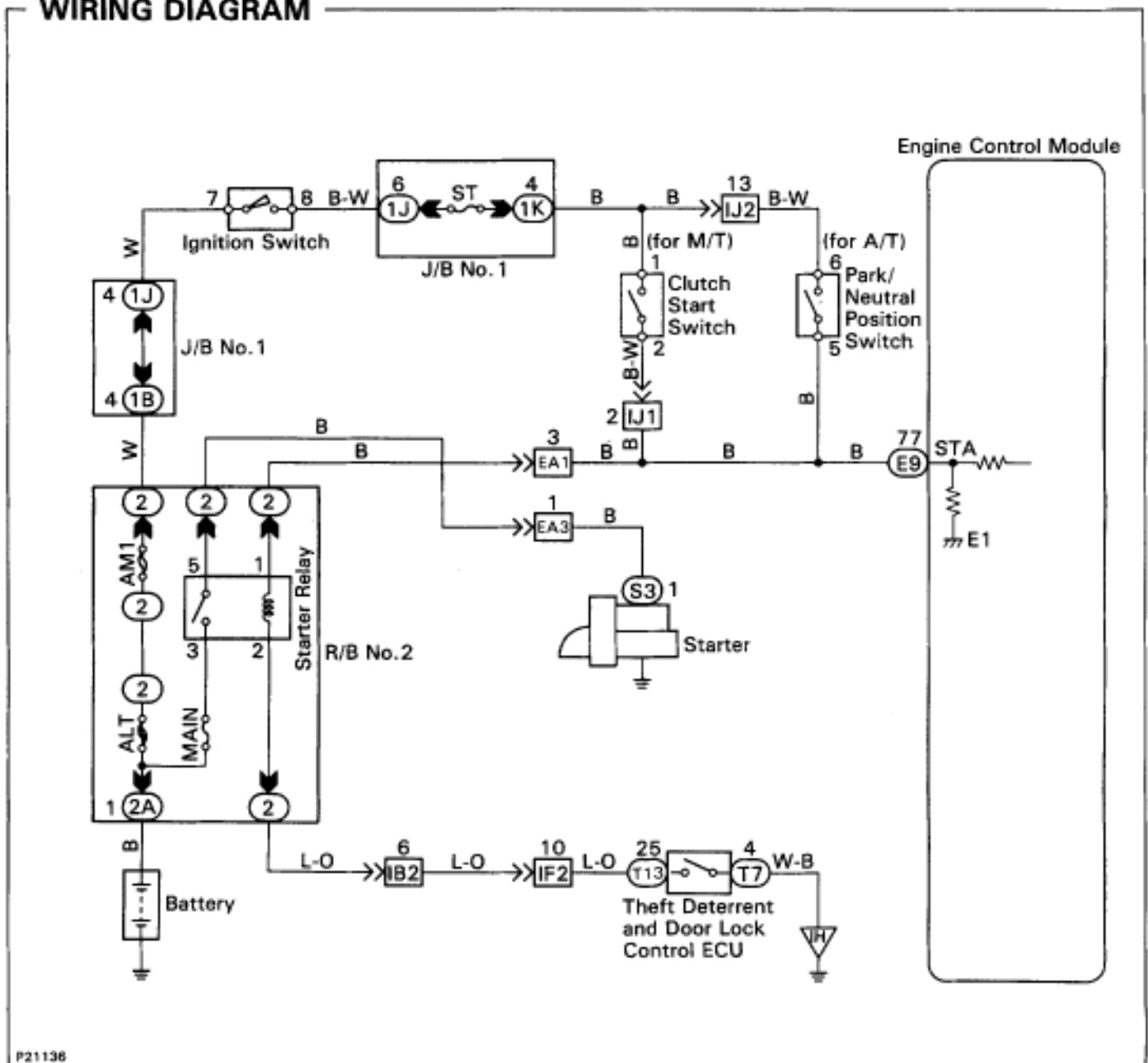

INSPECTION PROCEDURE

HINT: This diagnostic chart is based on the premise that the engine is being cranked under normal conditions.
If the engine does not crank, proceed to the matrix chart of problem symptoms on page [EG-408](#).

1	Check output condition of diagnostic trouble code 43.
 <p style="text-align: center;">CHECK</p> <p style="font-size: small;">F16914</p>	<p>P Setting the test mode.</p> <ol style="list-style-type: none"> (1) Turn ignition switch OFF. (2) Connect terminals TE2 and E1 of DLC2. (3) Turn ignition switch ON. (Don't start the engine) (4) Connect terminals TE1 and E1 of DLC2. <p>C Check if code "43" is output by the malfunction indicator lamp.</p> <p>OK Code "43" is output.</p> <p>C Start the engine. Check if code "43" disappears.</p> <p>OK Code "43" is not output.</p>
NG	OK Proceed to next circuit inspection shown on matrix chart (See page EG-408).
2	Check for open in harness and connector between engine control module and starter relay (See page IN-30).
OK	NG Repair or replace harness or connector.
<div style="border: 1px solid black; padding: 5px; display: inline-block;">Check and replace engine control module.</div>	

DTC 52 53 55 Knock Sensor Circuit

CIRCUIT DESCRIPTION

Knock sensors are fitted one each to the front and rear of the left side of the cylinder block to detect engine knocking. This sensor contains a piezoelectric element which generates a voltage when it becomes deformed, which occurs when the cylinder block vibrates due to knocking. If engine knocking occurs, ignition timing is retarded to suppress it.

DTC No.	Diagnostic Trouble Code Detecting Condition	Trouble Area
52	No No.1 knock sensor signal to ECM for 4 crank revolutions with engine speed between 1,600 rpm and 5,200 rpm	<ul style="list-style-type: none"> • Open or short in No.1 knock sensor circuit • No.1 knock sensor (looseness) • ECM
53	Engine control computer (for knock control) malfunction at engine speed between 650 rpm and 5,200 rpm	<ul style="list-style-type: none"> • ECM
55	No No.2 knock sensor signal to ECM for 4 crank revolutions with engine speed between 1,600 rpm and 5,200 rpm	<ul style="list-style-type: none"> • Open or short in No.2 knock sensor circuit • No.2 knock sensor (looseness) • ECM

If the ECM detects the above diagnosis conditions, it operates the fail safe function in which the corrective retard angle value is set to the maximum value.

DIAGNOSTIC TROUBLE CODE DETECTION DRIVING PATTERN

Purpose of the driving pattern.

- To simulate diagnostic trouble code detecting condition after diagnostic trouble code is recorded.
- To check that the malfunction is corrected when the repair is completed by confirming that diagnostic trouble code is no longer detected.

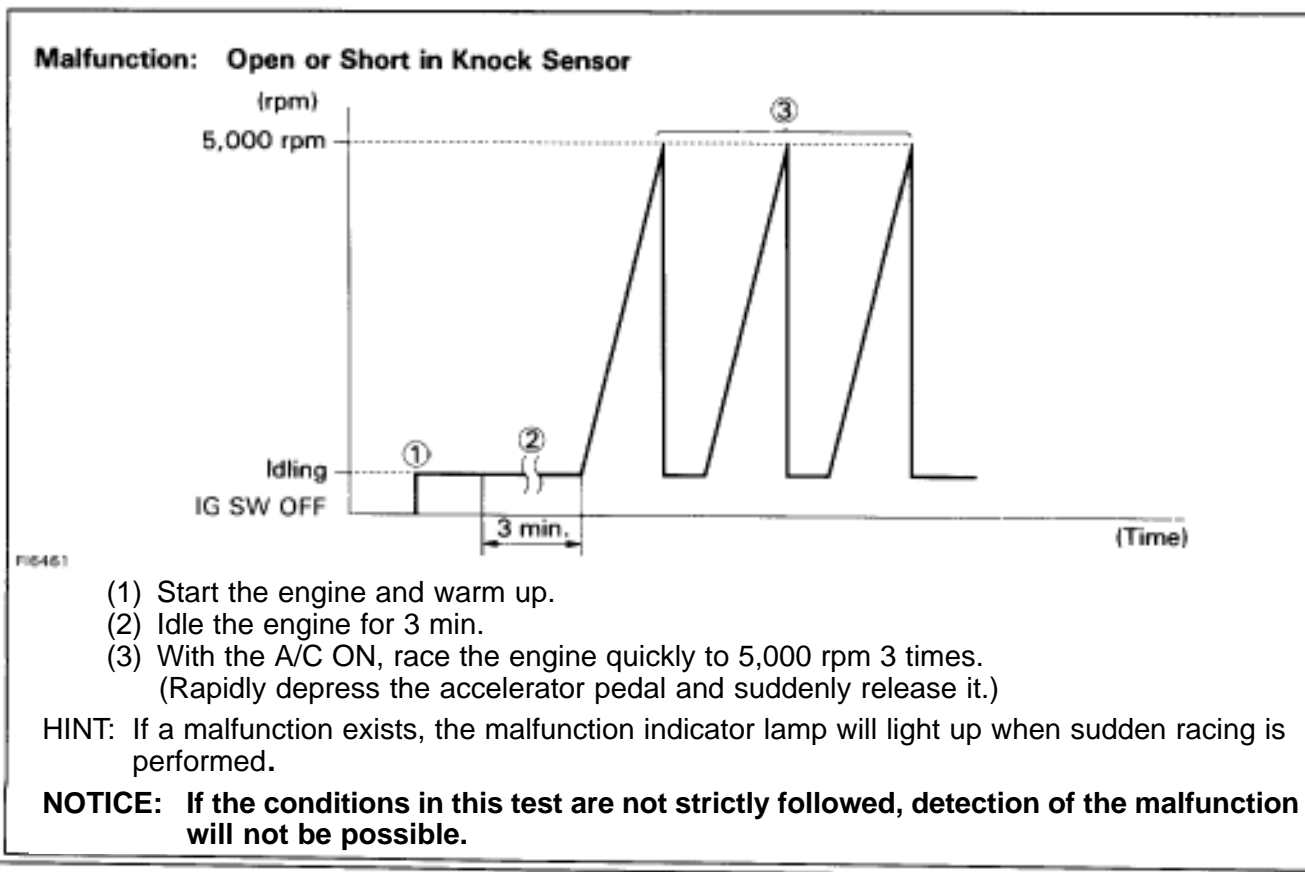

WIRING DIAGRAM

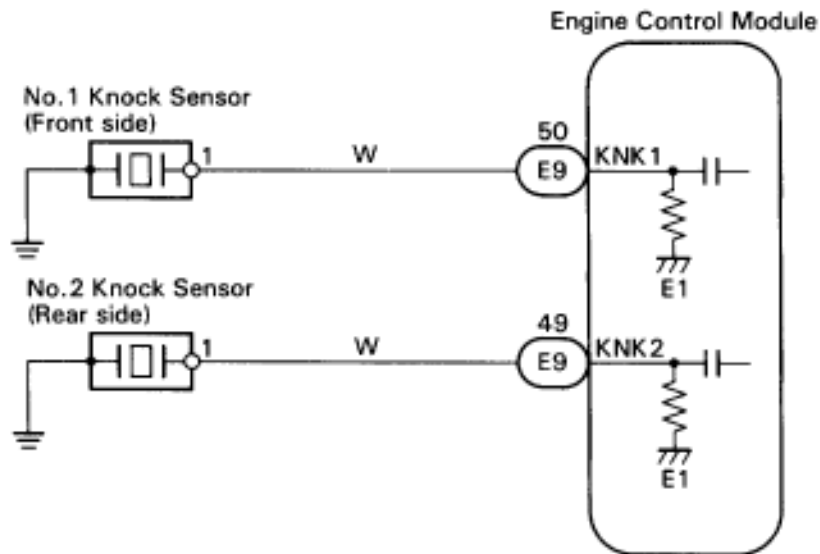

F16541

INSPECTION PROCEDURE

HINT: If diagnostic trouble code 52 is displayed, check No.1 knock sensor (for front side) circuit.
 If diagnostic trouble code 55 is displayed, check No.2 knock sensor (for rear side) circuit.
 If diagnostic trouble code 53 is displayed, replace engine control module.

1

Check continuity between terminals KNK1, KNK2 of engine control module connector and body ground.

LOCK

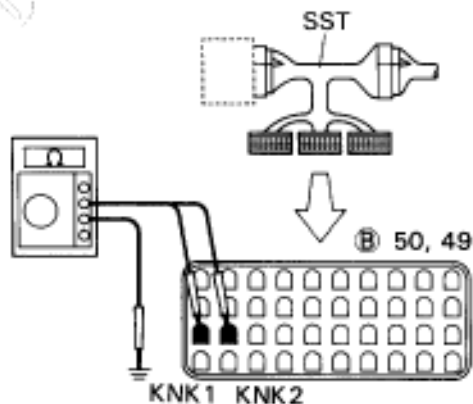
816653
F16506

- P** (1) Connect SST (check harness "A").
 (See page EG-404)
 SST 09990-01000
 (2) Disconnect the engine control module connectors.
- C** Measure resistance between terminals KNK1, KNK2 of engine control module connector and body ground.
- OK** Resistance: 1 MΩ or higher

NG

OK

Go to step 3 .

2 Check knock sensor.

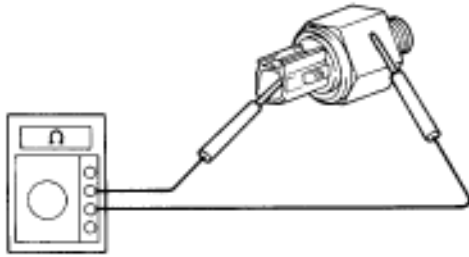

F16630

OK

- P** Disconnect knock sensor connector.
- C** Measure resistance between the knock sensor terminal and body.
- OK** Resistance: 1 MΩ or higher

NG

Replace knock sensor. (See page EG-245)

3 Check for open and short in harness and connector between engine control module and knock sensor (See page IN-30).

OK

NG

Repair or replace harness or connector.

4 Does malfunction disappear when a good knock sensor is installed?

NO

YES

Replace knock sensor. (See page EG-245)

Check and replace engine control module.

Reference

INSPECTION USING OSCILLOSCOPE

KNK Signal Waveform

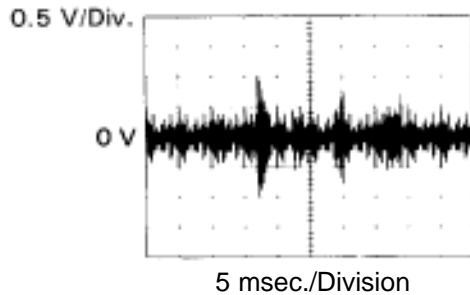

- With the engine racing (4,000 rpm) measure waveform between terminals KNK1, KNK2 of engine control module and body ground.

HINT: The correct waveform is as shown.

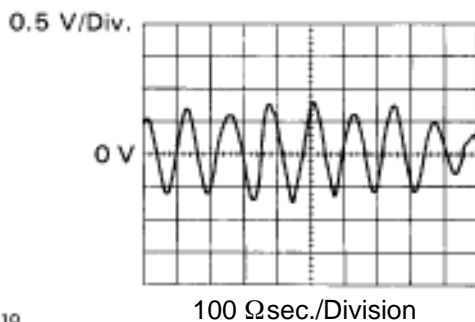

- Spread the time on the horizontal axis, and confirm that the period of the wave is 123 Ωsec. (Normal mode vibration frequency of knock sensor: 8.1 KHz).

HINT: If normal mode vibration frequency is not 8.1 KHz, the sensor is malfunctioning.

F16510
F16642

DTC 71 EGR System Malfunction

CIRCUIT DESCRIPTION

The EGR system is designed to recirculate the exhaust gas, controlled according to the driving conditions, back into the intake air-fuel mixture. It helps to slow down combustion in the cylinder and thus lower the combustion temperature which, in turn, reduces the amount of NOx emission. The amount of EGR is regulated by the EGR vacuum modulator according to the load.

If even one of the following conditions is fulfilled, the VSV is turned ON by a signal from the ECM. This results in atmospheric air acting on the EGR valve, closing the EGR valve and shutting off the exhaust gas (EGR cut-OFF).

- Engine coolant temp. below 50°C (122°F)
- During deceleration (Throttle valve closed)
- Light engine load (amount of intake air very small).
- Engine speed over 5,200 rpm
- Traction control is operating

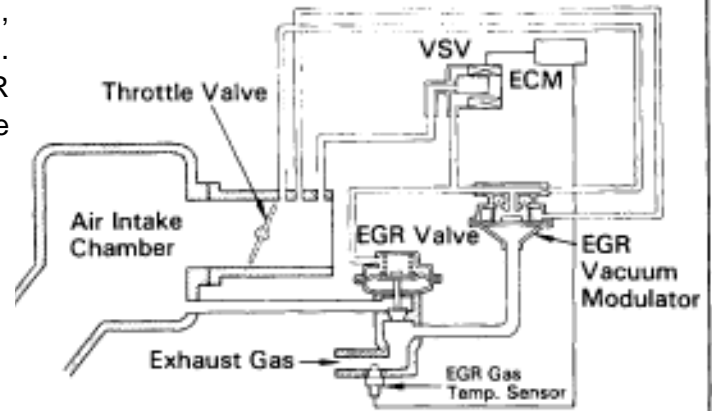

F16895

DTC No.	Diagnostic Trouble Code Detecting Condition	Trouble Area
71	EGR gas temp. is 70°C (158°F) or less for 1 ~ 4 min. under conditions (a) and (b): (2) trip detection logic)* (a) Engine coolant temp.: 63°C (145°F) or more (b) EGR operation possible (Example A/T in 3rd speed (5th for M/T), A/C ON, 96 km/h (60 mph), Flat road)	<ul style="list-style-type: none"> • Open in EGR gas temp. sensor circuit • Short in VSV circuit for EGR • EGR hose disconnected, valve stuck • Clogged EGR gas passage • ECM

(See page [EG-397](#)).

DIAGNOSTIC TROUBLE CODE DETECTION DRIVING PATTERN

Purpose of the driving pattern.

- (a) To simulate diagnostic trouble code detecting condition after diagnostic trouble code is recorded.
- (b) To check that the malfunction is corrected when the repair is completed by confirming that diagnostic trouble code is no longer detected.

CIRCUIT DESCRIPTION (Cont'd)

Malfunction: Open in EGR Gas Temp. Sensor Circuit

(Vehicle Speed)

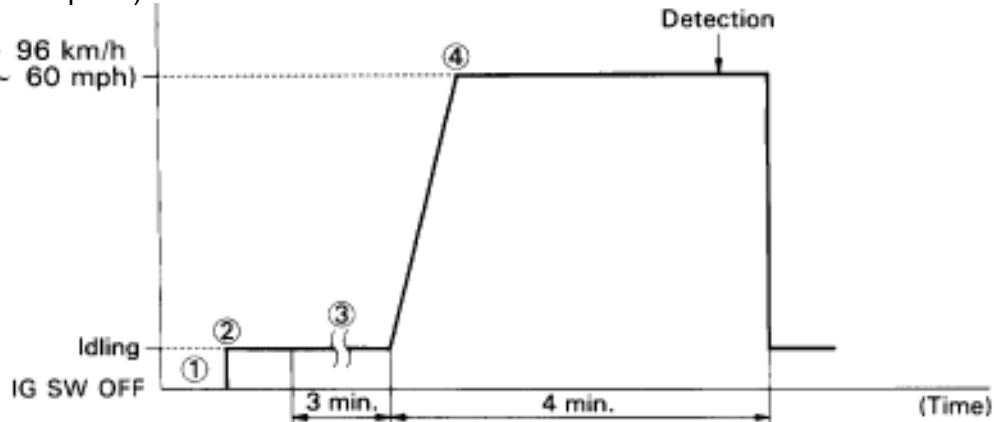
88 ~ 96 km/h
(55 ~ 60 mph)

F16528

- (1) Disconnect the EFI No.1 fuse (30A) for 10 sec. or more, with IG switch OFF. Initiate test mode (Connect terminal TE2 and E1 of data link connector 2 with IG switch OFF).
- (2) Start engine and warm up.
- (3) Idle the engine for 3 min.
- (4) With the A/C ON and transmission in 5th position (A/T in 3rd speed) drive at 88 ~ 96 km/h (55 ~ 60 mph) for 4 min. or less.

HINT: If a malfunction exists, the malfunction indicator lamp will light up during step (4).

NOTICE: If the conditions in this test are not strictly followed, detection of the malfunction will not be possible.

WIRING DIAGRAM

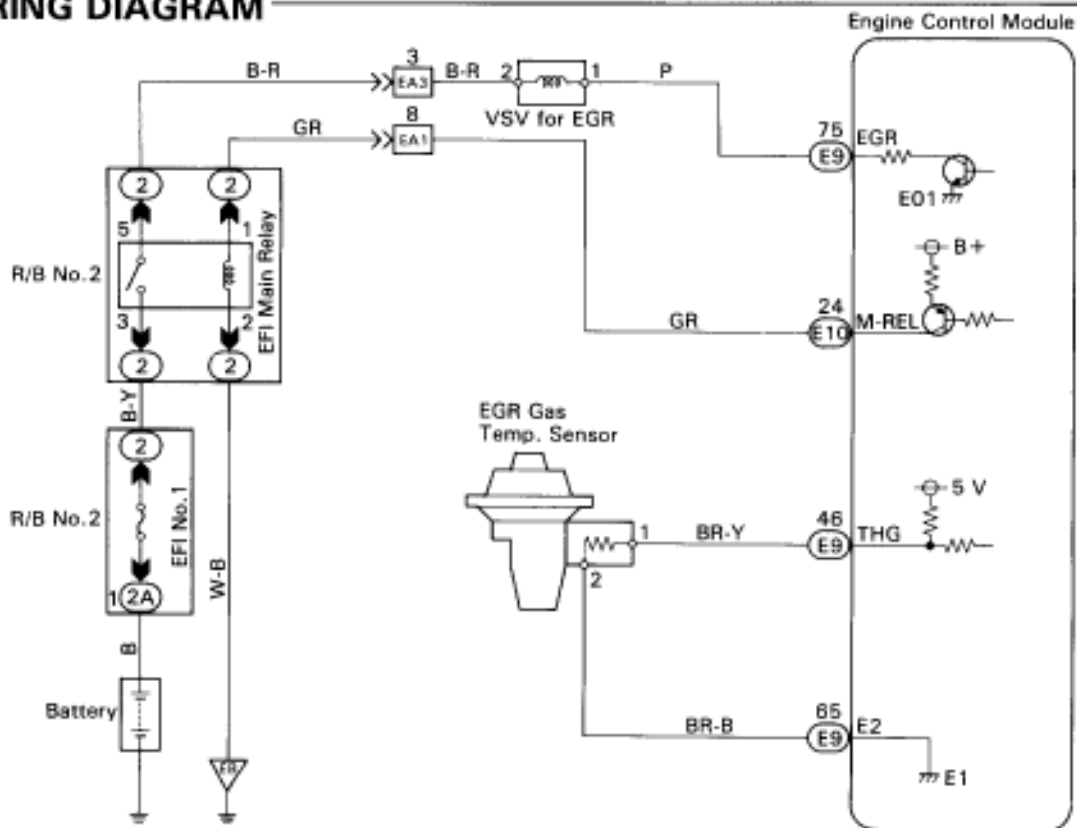

F16949

INSPECTION PROCEDURE

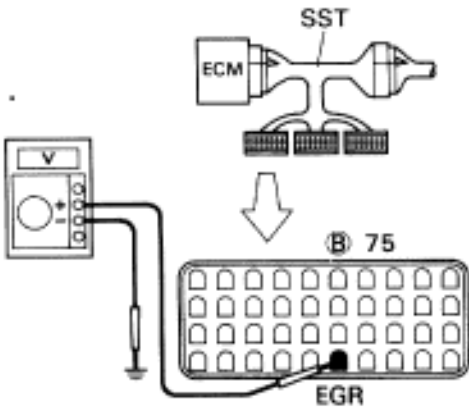
1 Check voltage between terminal EGR of engine control module connector and body ground.	
 <p>F16620</p>	<p>P (1) Connect SST (check harness "A"). (See page EG-404) SST 09990-0100 (2) Warm up engine to normal operating temperature.</p> <p>C Measure voltage between terminal EGR of engine control module connector and body ground.</p> <p>OK Voltage: 9 — 14 V</p>
NG	OK Go to step 4 .

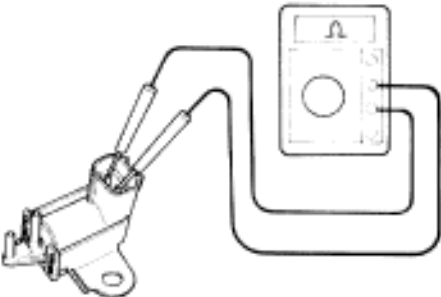
2 Check resistance between terminals of VSV for EGR.	
 <p>F16632</p>	<p>P Remove VSV for EGR. (See page EG-240)</p> <p>C Measure resistance between terminals of VSV for EGR.</p> <p>OK Resistance: 38.5 — 44.5 Ω at 20°C (68°F)</p>
OK	NG Replace VSV for EGR.

3 Check for open and short in harness and connector between EFI main relay and VSV for EGR, VSV for EGR and engine control module. (See page IN-30)	
OK	NG Repair or replace harness of connector.

Check and replace engine control module.

4 Check EGR system (See page Eg-168).

OK

NG Repair EGR system.

5 Check resistance of EGR gas temp. sensor.

EGR Gas Temp. Sensor

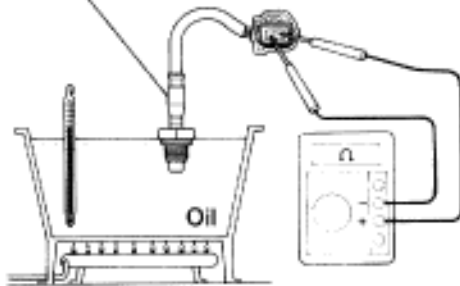

P03193

P Remove EGR gas temp. sensor.**C** Measure resistance between terminals of EGR gas temp. sensor connector.

OK Resistance: 64 — 97 k Ω at 50°C (122°F)
 11 — 16 k Ω at 100°C (212°F)
 2 — 4 k Ω at 150°C (302°F)

OK

NG Replace EGR gas temp. sensor.

6 Check for open in harness and connector between EGR gas temp. sensor and engine control module. (See page IN-30)

OK

NG Repair or replace harness or connector.

Check and replace engine control module.

DTC 78 Fuel Pump Control Circuit

CIRCUIT DESCRIPTION

The fuel pump speed is controlled at 2 steps (high speed, low speed) by the condition of the engine (starting, light load, heavy load), when the engine starts (STA ON), the engine control module sends a Hi signal (battery positive voltage) to the fuel pump ECU (FPC terminal).

The fuel pump ECU then outputs Hi voltage (battery positive voltage) to the fuel pump so that the fuel pump operates at high speed.

After the engine starts, during idling or light loads, the engine control module outputs a Low signal (about 9 V) to the fuel pump ECU, the fuel pump ECU outputs Lo battery voltage (about 9 V) to the fuel pump and causes the fuel pump to operate at low speed.

If the intake air volume increases (high engine load), the engine control module sends a Hi signal to the fuel pump ECU and causes the fuel pump to operate at high speed.

DTC No.	Diagnostic Trouble Code Detecting Condition	Trouble Area
78	(1) Open or short in fuel pump circuit for 1 sec. Or more with engine speed 1,000 rpm or less (2 trip detection logic)*	<ul style="list-style-type: none"> • Open or short in fuel pump ECU circuit • Fuel pump ECU • Engine control module power source circuit • Fuel pump • Engine control module
	(2) Open in input circuit of fuel pump ECU (FPC) with engine speed 1,000 rpm or less (2 trip detection logic)*	
	(3) Open or short in diagnostic signal line (DI) of fuel pump ECU with engine speed 1,000 rpm or less (2 trip detection logic)*	

*: See page EG-397.

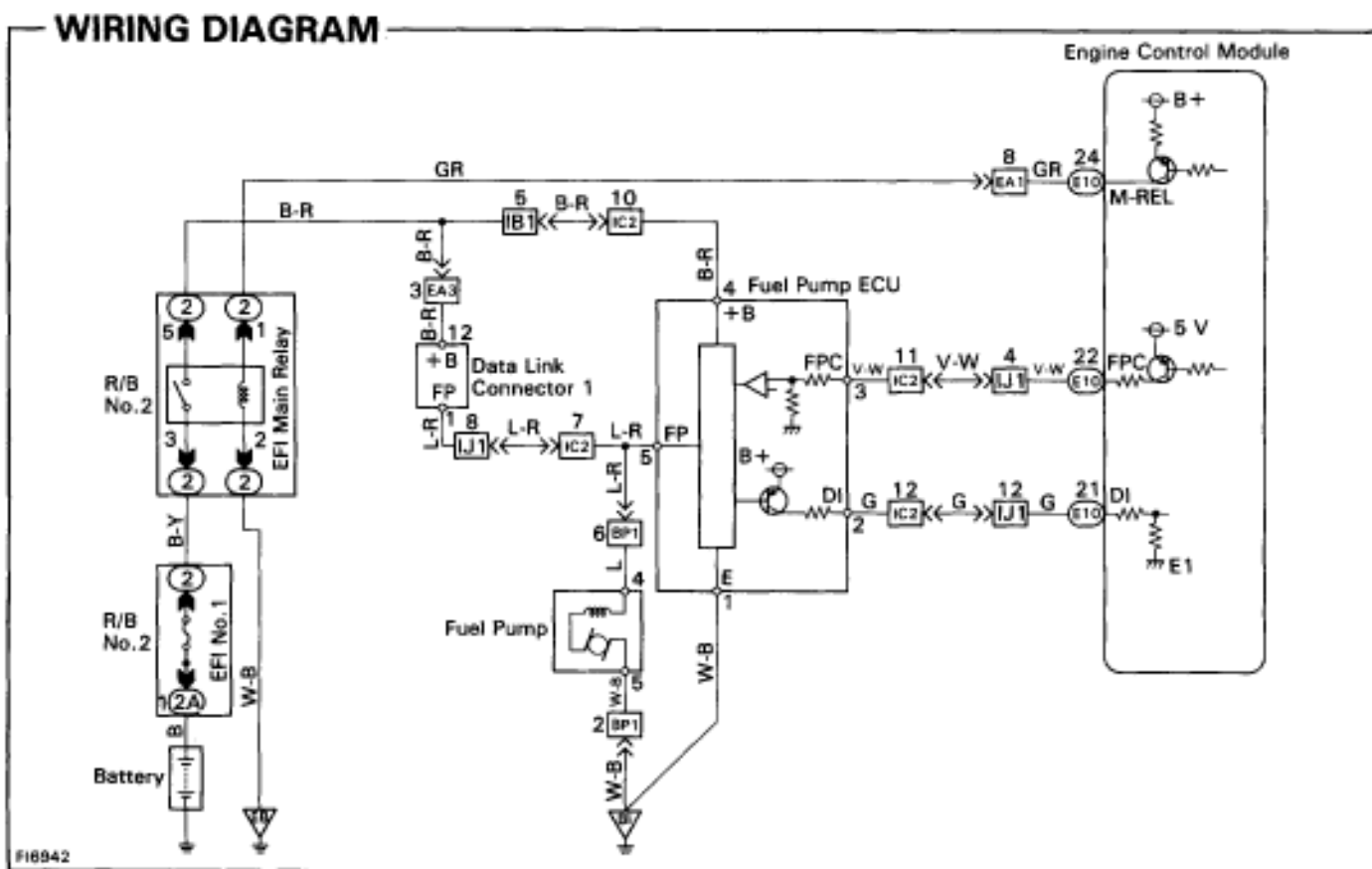

INSPECTION PROCEDURE

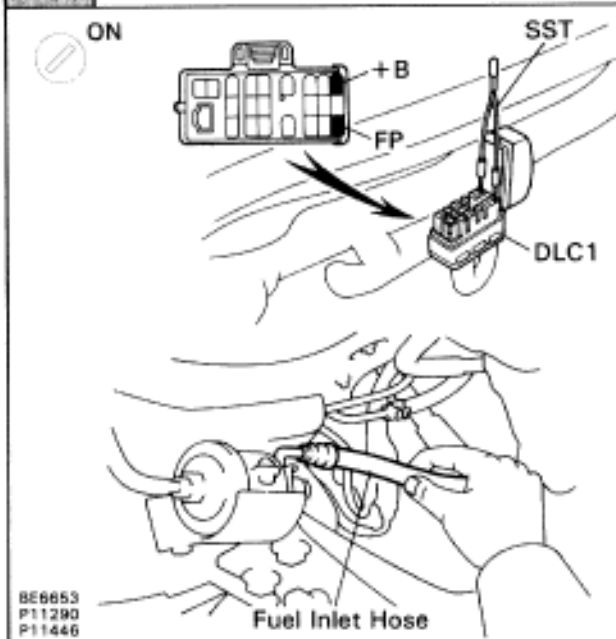
1**Check fuel pump operation.**

- P** (1) Turn ignition switch ON.
(2) Using SST, connect terminals +B and FP of data link connector 1.
SST 09843-18020
- C** Check that there is pressure in the hose from the fuel filter.
- OK** Fuel pressure can be felt.

OK

NG > Go to step **3**.**2****Check for open and short in harness and connector between terminals +B ↔ +B, FP ↔ FP of the data link connector 1 and fuel pump ECU (See page IN-30).**

NG

OK > Go to step **5**.

Repair or replace harness or connector.

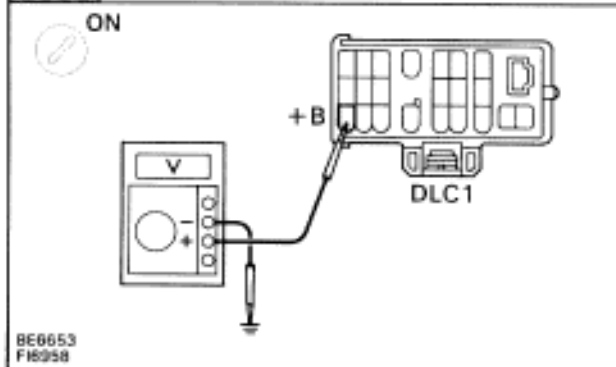
3**Check voltage of terminal +B of data link connector 1.**

- P** Turn ignition switch ON.
- C** Measure voltage between terminal +B of data link connector 1 and body ground.
- OK** Fuel pressure can be felt.

OK

NG > Check for ECM power source circuit (See page EG-465), and check for open in harness and connector between terminal +B of data link connector 1 and main relay.

4 Check for open and short in harness and connector between terminal FP of data link connector 1, fuel pump and body ground (see page IN-30).

NG

OK Repair or replace fuel pump.

Repair or replace harness or connector.

5 Check voltage between terminals 3 (FPC) and 1 (E) of fuel pump ECU connector.

START

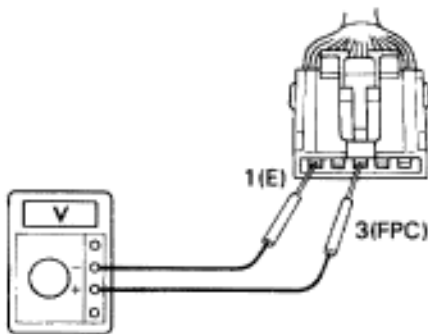

- P** (1) Remove the LH quarter trim panel.
(See page EG-252)
(2) Disconnect fuel pump ECU connector.

C Measure voltage between terminals 3 (FPC) and 1 (E) of fuel pump ECU connector when ignition switch is turned to START.

OK Voltage: 4.5 — 5.5 V

NG

OK Replace fuel pump ECU.

6 Check for open in harness and connector between terminal FPC of engine control module and terminal 3 (FPC) of fuel pump ECU, terminal 1 (E) of fuel pump ECU and body ground (See page IN-30).

OK

NG Repair or replace harness or connector.

7 Check for open and short in harness and connector between terminal DI of engine control module and terminal 2 (DI) of fuel pump ECU (See page IN-30).

OK

NG Repair or replace harness or connector.

Check and replace engine control module.

DTC 51 Switch Condition Signal Circuit CIRCUIT DESCRIPTION

Park/Neutral Position Switch

The ECM uses the signals from the park/neutral position switch to determine whether the transmission is in park or neutral, or in some other position.

Air Conditioning Switch Signal

The ECM uses the output from the air conditioning switch to determine whether or not the air conditioning is operating so that it can increase the idling speed of the engine if necessary.

Throttle Position Sensor IDL Signal

The IDL contacts are mounted in the throttle position sensor, and detects the idle condition.

DTC No.	Diagnostic Trouble Code Detecting Condition	Trouble Area
51	(1) 3 sec. or more after engine starts with closed throttle position switch OFF (IDL1) (2) Park/neutral position switch: OFF (Shift position in "R", "D", "2" or "L" position.) (3) A/C switch ON	<ul style="list-style-type: none"> • Throttle position sensor IDL circuit • Accelerator pedal and cable • Park/neutral position switch • A/C switch circuit • ECM

HINT: In this circuit, diagnoses can only be made in the test mode.

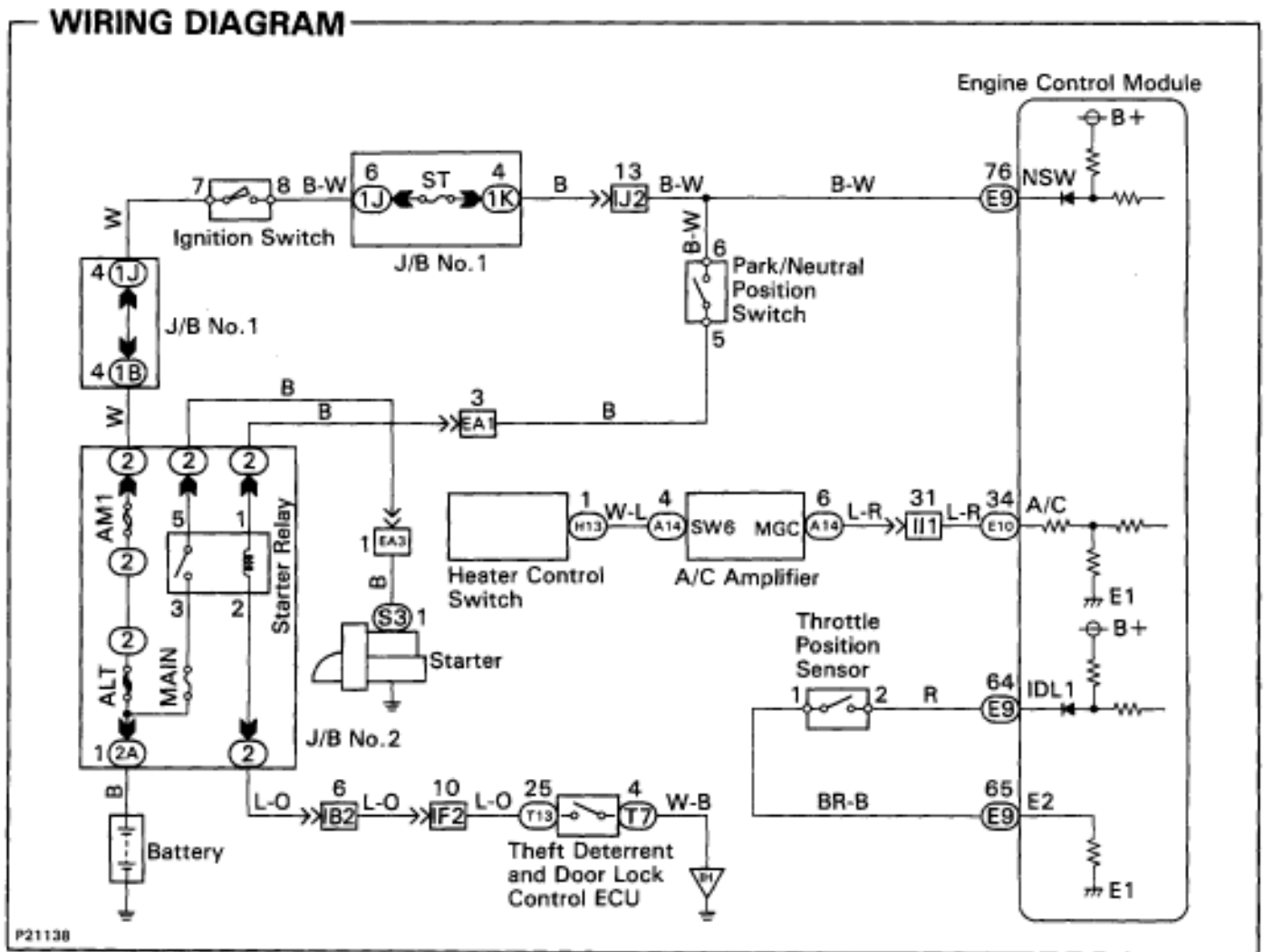

INSPECTION PROCEDURE

1**Check output condition of diagnostic trouble code 51.**

FIG014

- P** Setting the test mode.
- (1) Turn ignition switch OFF.
 - (2) Connect terminals TE2 and E1 of DLC2.
 - (3) Turn ignition switch ON.
(For checking terminal IDL, disconnect the vacuum hose from the throttle body, then apply vacuum to the throttle opener (See page [EG-219](#))).
(For checking terminal A/C, start the engine.)
 - (4) Connect terminals TE1 and E1 of DLC1 or DLC2.

- C** Check if code "51" is output by the malfunction indicator lamp.

OK	Condition	Code
Park/Neutral Position Switch (PNP)	P or N position	Normal*
	R, D, 2 or L position	51*
Throttle Position Sensor (IDL1)	Accelerator pedal released	Normal*
	Accelerator pedal depressed	51*
A/C Switch (A/C)	A/C SW ON	51
	A/C SW OFF	Normal

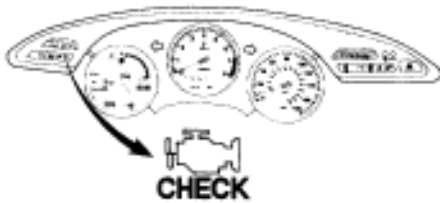
*: Before the STA signal is input (ST is not ON), diagnostic trouble code 43 is also output.

- Hint** Diagnostic trouble code 42 is output with vehicle speed 5 km/h (3 mph) or below.

OK

NG

IDL1...Go to step [2].
PNP....Go to page [EG-463](#).
A/C....Go to step [3].

Proceed to next circuit inspection shown on matrix chart (See page [EG-408](#)).

2**Check throttle position sensor.**

P11462

- P** (1) Disconnect throttle position sensor connector.
 (2) Disconnect the vacuum hose from the throttle body. then apply vacuum to the throttle opener (See page EG-219).

- C** Measure resistance between terminals 2 (IDL1) and 1 (E2) of throttle position sensor connector.

Throttle Valve	Resistance
Fully closed	Less than 0.5 kΩ
Opened	1 MΩ or higher

OK**NG**

Adjust or replace throttle position sensor.
 (See page EG-223)

Check and repair harness or connector between engine control module and throttle position sensor.

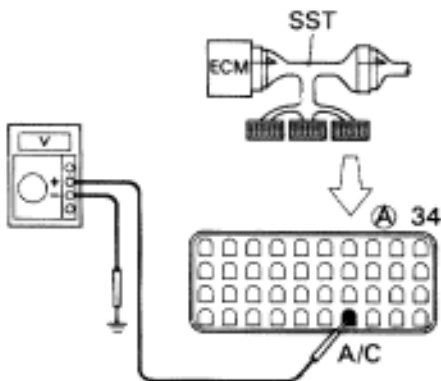
3**Check voltage between terminal A/C of engine control module connector and body ground.**

F16893

- P** (1) Connect SST (check harness "A").
 (See page EG-404)
 SST 09990-01000
 (2) Start the engine.

- C** Measure voltage between terminal A/C of engine control module and body ground.

A/C Switch	Voltage
OFF	7.5 - 14 V
ON	0 - 1.5 V

OK**NG**

Check A/C compressor circuit.
 (See page AC-62)

Check and replace engine control module.

Park Neutral Position Switch Circuit

CIRCUIT DESCRIPTION

The park/neutral position switch goes on when the shift lever is in the N or P shift position. When it goes on the terminal NSW of the ECM is grounded to body ground via the starter relay and theft deterrent ECU, thus the terminal NSW voltage becomes 0 V. When the shift lever is in the D, 2, L or R position, the park/neutral position switch goes off, so the voltage of ECM terminal NSW becomes positive battery voltage, the voltage of the ECM internal power source.

If the shift lever is moved from the N position to the D position, this signal is used for air-fuel ratio correction and for idle speed control (estimated control), etc.

When the park/neutral position switch is off, code "51" is output in the test mode diagnosis. (This is not abnormal.)

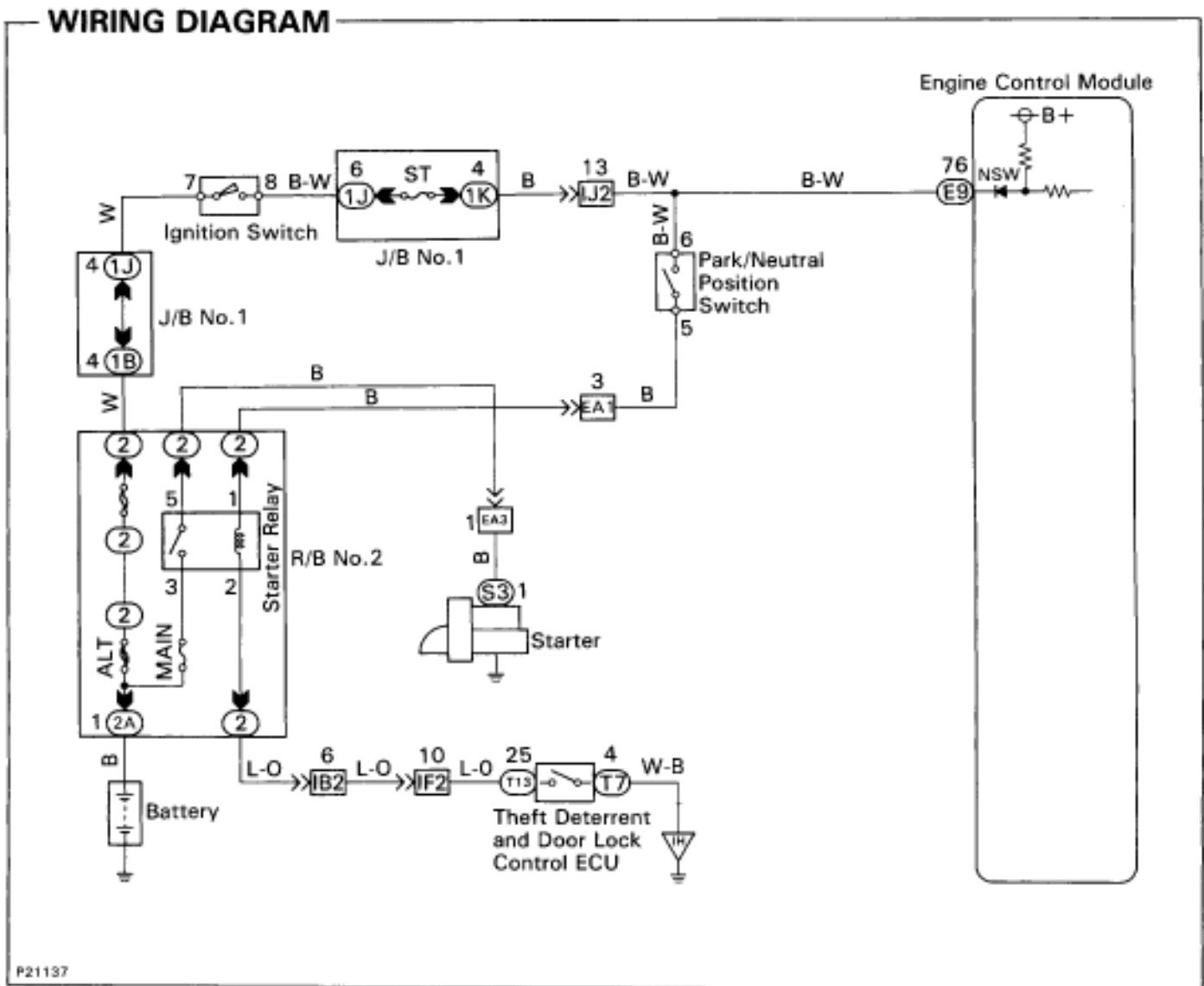

INSPECTION PROCEDURE

HINT: This diagnostic chart is based on the premise that the engine is being cranked under normal conditions. If the engine does not crank, proceed to the matrix chart of problem symptoms on page [EG-408](#).

1 Check output condition of diagnostic trouble code 51



F16914

P (1) Connect terminals TE2 and E1 of DLC2.
 (2) Turn ignition switch ON.
 (3) Crank the engine.
 (4) Connect terminals TE1 and E1 of DLC2.

C Check if diagnostic trouble code "51" is output when the shift lever is in the P and D shift positions.

Result

Shift Position	Result		
	OK	NG Type I	NG Type II
"P"	Normal Code	Code 51	Normal Code
"D"	Code 51	Code 51	Normal Code

OK

NG Type I Go to step **2**.

NG Type II Go to step **3**.

Proceed to next circuit inspection shown on matrix chart (See page Eg-408).

2 Check for open in harness and connector between engine control module and park/neutral position switch (See page IN-30).

NG

OK

Check and replace engine control module.

Repair or replace harness or connector.

3 Check park/neutral position switch (See page AT1-81).

OK

NG

Replace park/neutral position switch.

Check and replace engine control module.

ECM Power Source Circuit

CIRCUIT DESCRIPTION

When the ignition switch is turned on, battery voltage is applied to the terminals IGSW of the ECM, and the main relay control circuit in the ECM sends a signal to the terminal M-REL of the ECM, switching on the main relay. This signal causes current to flow to the coil, closing the contacts of the main relay and supplying power to the terminal +B of the ECM.

If the ignition switch is turned off, the ECM continues to switch on the main relay for a maximum of 2 seconds for the initial setting of the IAC valve.

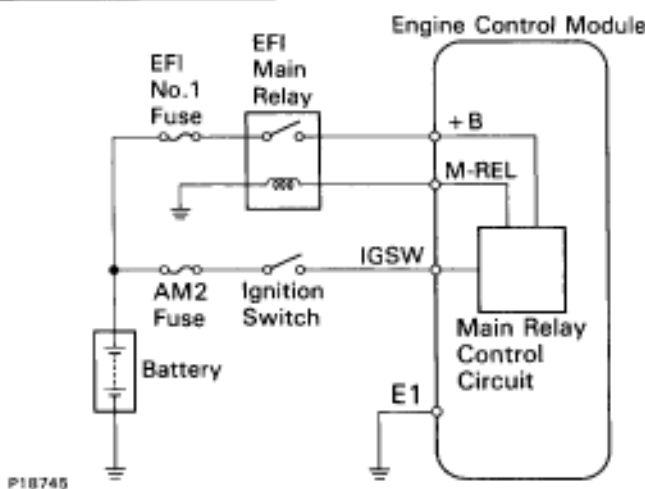

P18745

WIRING DIAGRAM

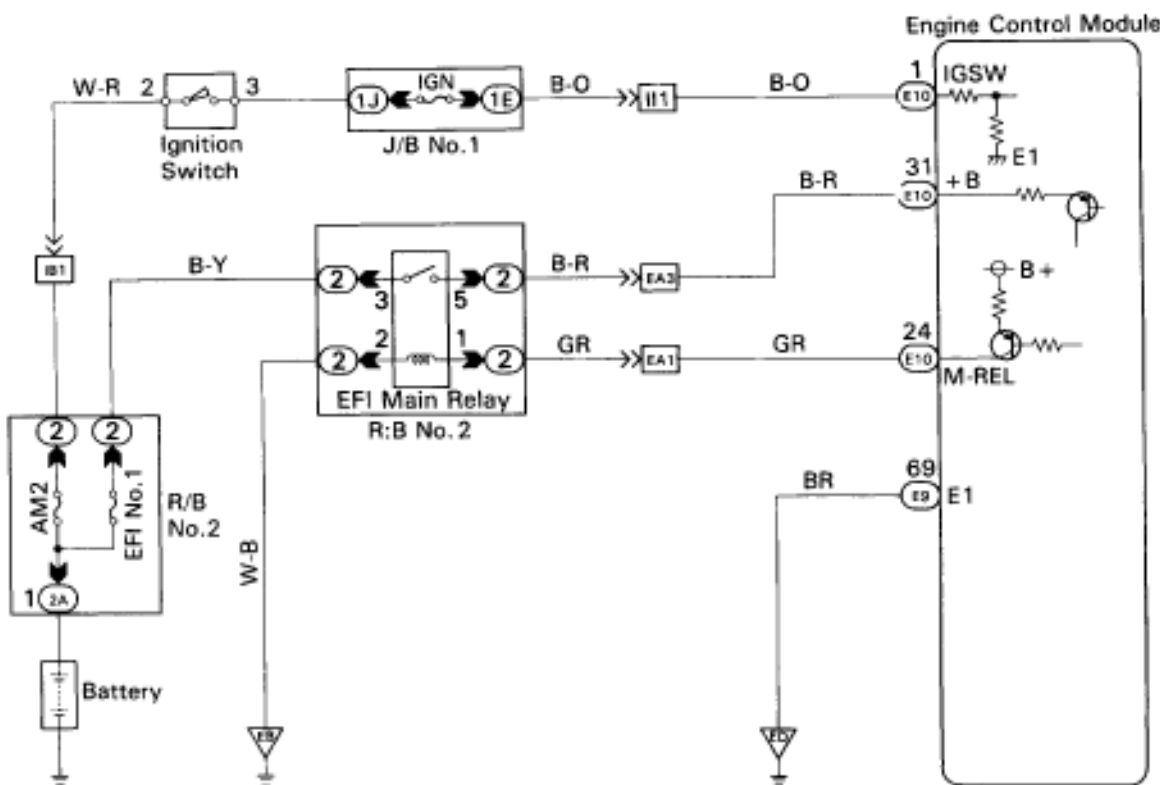

P18746

INSPECTION PROCEDURE

1 Check voltage between terminal +B and E1 of engine control module connector.

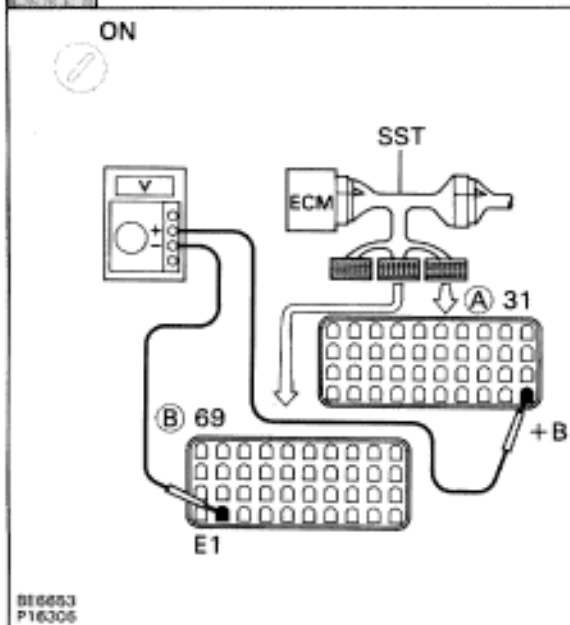

- P** (1) Connect SST (check harness "A").
(See page Eg-404)
SST 09990-01000
(2) Turn ignition switch ON.
- C** Measure voltage between terminal +B and E1 of engine control module connector.
- OK** Voltage: 9 — 14 V

NG

OK Proceed to next circuit inspection shown on matrix chart (See page EG-408).

2 Check for open in harness and connector between terminal E1 of engine control module and body ground (See page IN-30).

OK

NG Repair or replace harness or connector.

3 Check voltage between terminal IGSW Check and replace engine control module connector and body ground.

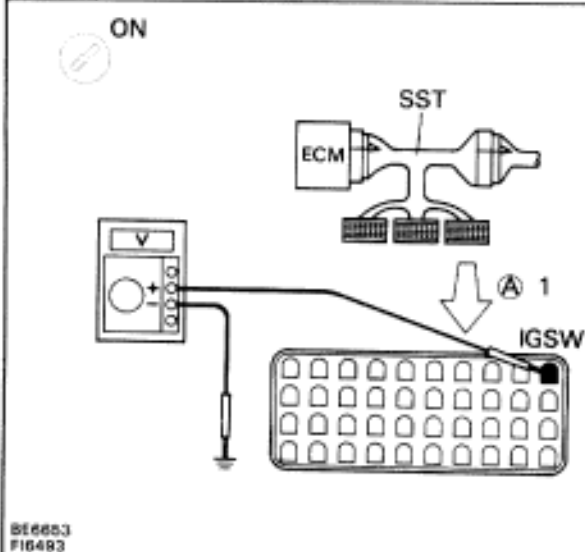

- P** Turn ignition switch ON.
- C** Measure voltage between terminal IGSW of engine control module connector and body ground.
- OK** Voltage: 9 — 14 V

NG

OK Go to step **6**.

4 Check IGN fuse.

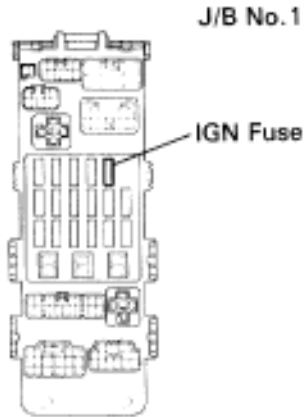

NOB417

- P** Remove IGN fuse from J/B No.1.
- C** Check continuity of IGN fuse.
- OK** Continuity

OK

NG Check for short in the harness and all the components connected to IGN fuse (See Electrical Wiring Diagram).

5 Check ignition switch.

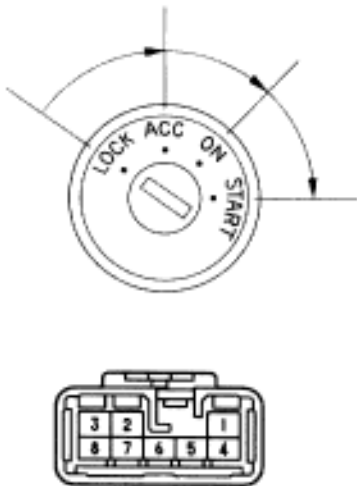

BE3582
g-8-2

- P** (1) Remove finish lower panel and finish lower panel LH.
(2) Remove heater to register duct No.2.
- C** Check continuity between terminals.

OK

○—○ continuity

Terminal Switch position	1	2	3	4	5	7	8
LOCK							
ACC					○—○		
ON		○—○	○—○	○—○	○—○		
START	○—○	○—○	○—○	○—○	○—○	○—○	

OK

NG Replace ignition switch.

Check and repair harness and connector between battery and ignition switch, ignition switch and engine control module.

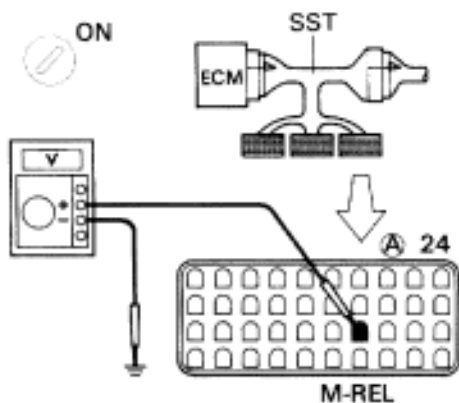
6**Check voltage between terminal M-REL of engine control module connector and body ground.**BE6653
F1B491

- P** Turn ignition switch ON.
- C** Measure voltage between terminal M-REL of engine control module connector and body ground.
- OK** Voltage: 9 — 14 V

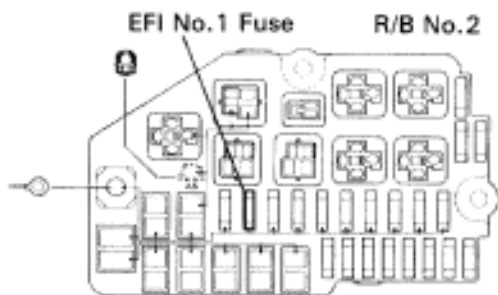
OK**NG** Check and replace engine control module.**7****Check EFI No.1 Fuse.**

N08419

- P** Remove EFI No.1 fuse from R/B No.2.
- C** Check continuity of EFI No.1 fuse.
- OK** Continuity

OK**NG** Check for short in the harness and all the components connected to EFI No.1 fuse (See Electrical Wiring Diagram).

8

Check EFI main relay.

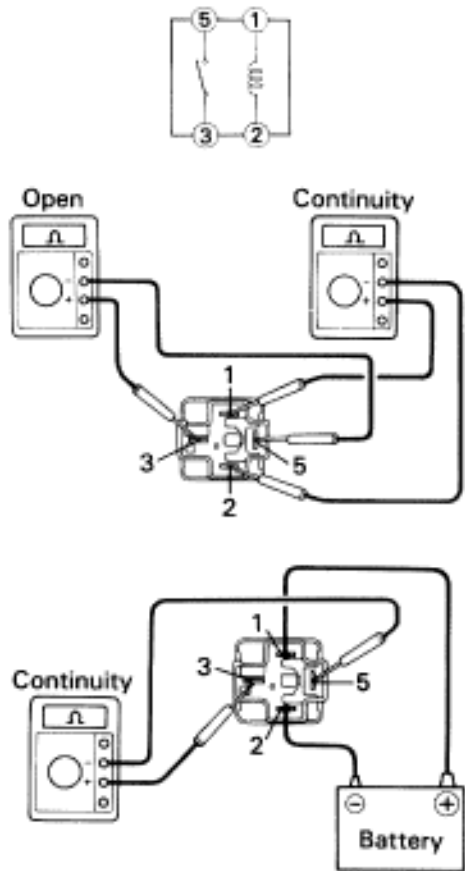

BE1841
P04590
P04591

P Remove EFI main relay from R/B No.2.

C Check continuity between terminals of EFI main relay shown below.

OK	Terminals 3 and 5	Open
	Terminals 1 and 2	Continuity (Reference value 72 Ω)

C (1) Apply battery voltage between terminals 1 and 2.
(2) Check continuity between terminals 3 and 5.

OK	Terminals 3 and 5	Continuity
-----------	-------------------	------------

OK

NG Replace EFI main relay.

9

Check for open and short in harness and connector between terminal M-REL of engine control module and body ground(See page IN-30).

OK

NG Repair or replace harness or connector.

Check and repair harness or connector between EFI No.1 fuse and battery.

Back Up Power Source Circuit

CIRCUIT DESCRIPTION

Battery positive voltage is supplied to terminal BATT of the ECM even when the ignition switch is off for use by the diagnostic trouble code memory and air-fuel ratio adaptive control value memory, etc.

WIRING DIAGRAM

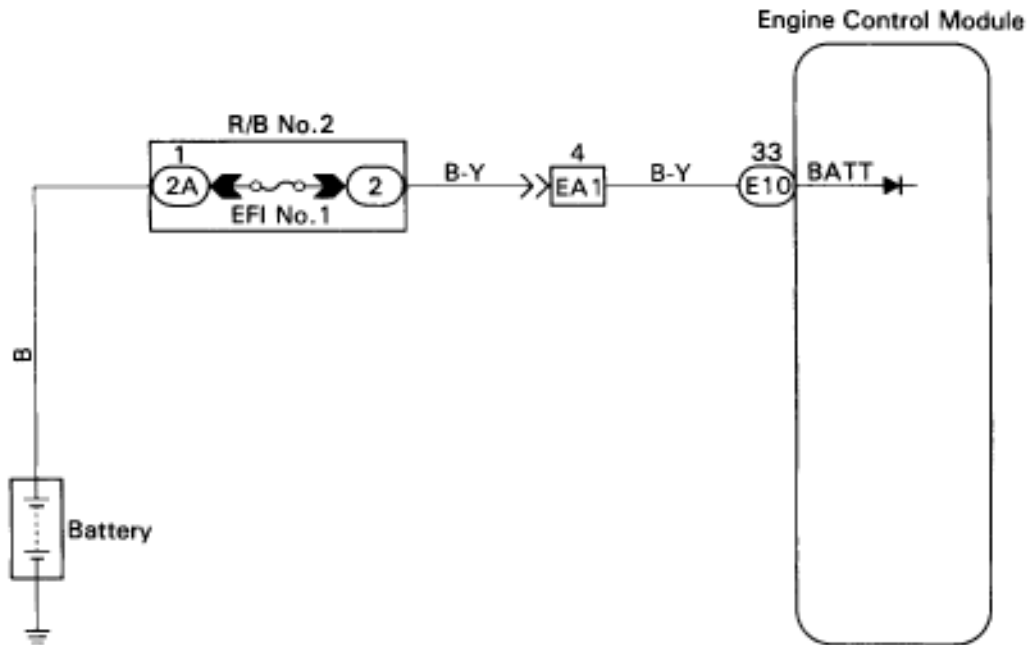

F16878

INSPECTION PROCEDURE

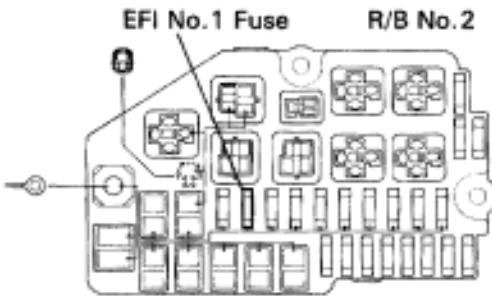
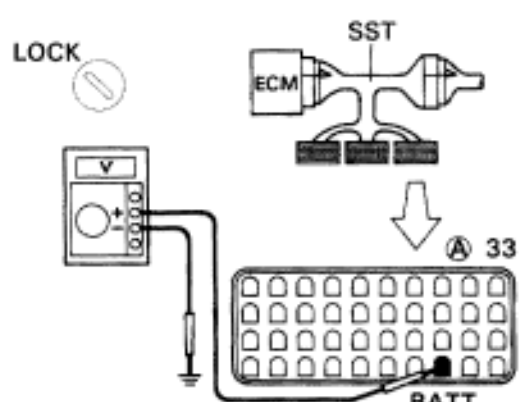
1	Check EFI No.1 Fuse.	 <p>N08419</p> <p>P Remove EFI No.1 fuse from R/B No.2.</p> <p>C Check continuity of EFI No.1 fuse.</p> <p>OK Continuity</p>
OK	NG Check for short in the harness and all the components connected to EFI No.1 fuse (See Electrical Wiring Diagram).	
2	Check voltage between terminal BATT of engine control module connector and body ground.	 <p>BE8853 F16490</p> <p>P Connect SST (check harness "A"). (See page EG-404) SST 09990-01000</p> <p>C Measure voltage between terminal BATT of engine control module connector and body ground.</p> <p>OK Voltage: 9 — 14 V</p>
OK	NG Check and repair harness or connector between engine control module and EFI No.1 fuse, EFI No.1 fuse and battery.	
3	Are the diagnostic trouble codes still in the memory when the ignition switch is turned OFF?	
YES	NO Check and replace engine control module.	

Proceed to next circuit inspection shown on matrix chart (See page EG-408).

Injector Circuit

CIRCUIT DESCRIPTION

The injectors are located in the intake manifold. They inject fuel into the cylinders based on the signals from the engine control module.

Reference

INSPECTION USING OSCILLOSCOPE

- With the engine idling measure waveform between terminals #10 ~ 60 and E01 of engine control module.

HINT: The correct waveform is as shown.

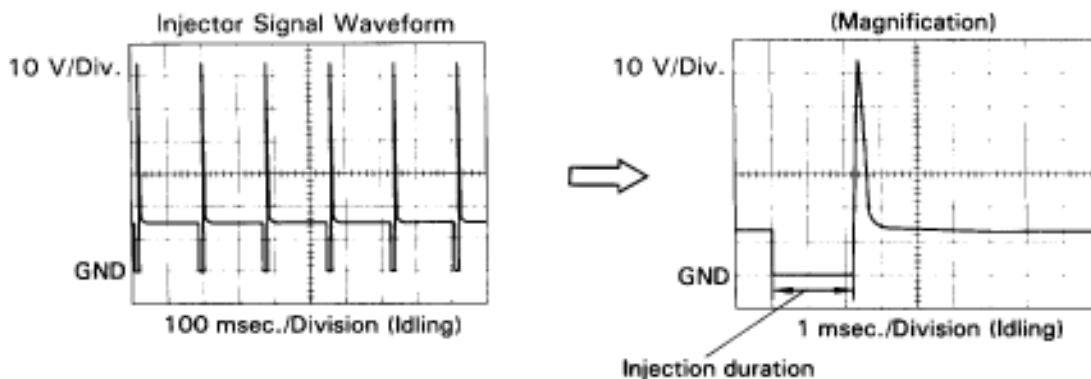

FIG588 FIG538

WIRING DIAGRAM

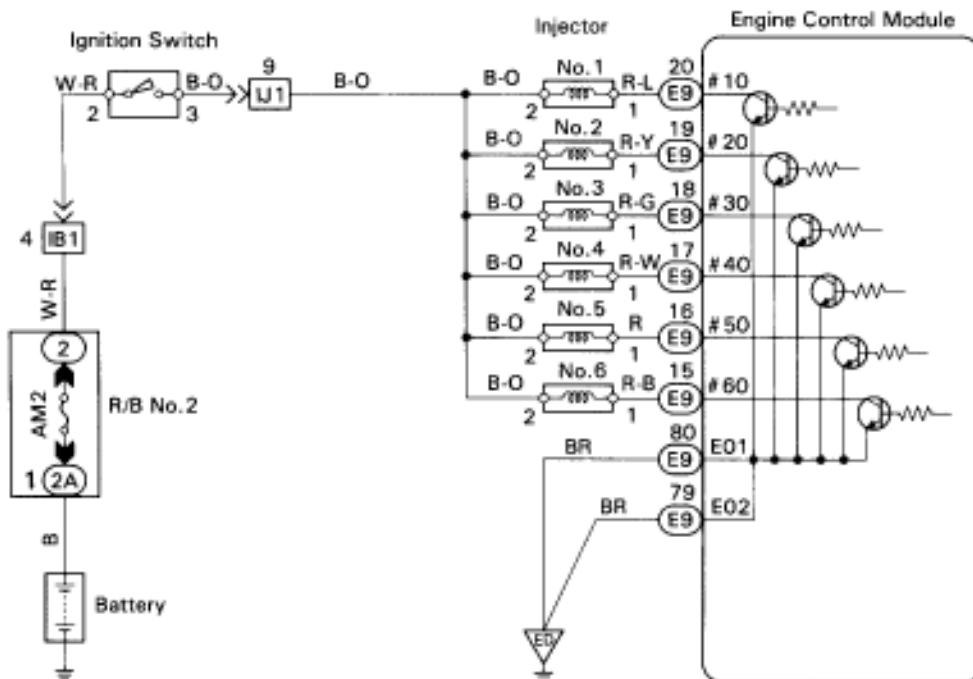

FIG944

INSPECTION PROCEDURE

1	Check voltage between terminals # 10 ~ 60 of engine control module and body ground.
	<p>P (1) Connect SST check harness "A". (See page EG-404) SST 09990-01000 (2) Turn ignition switch ON.</p> <p>C Measure voltage between terminals #10 ~ 60 of engine control module and body ground.</p> <p>OK Voltage: 9 — 14 V</p>
NG	OK Go to step 3 .

2	Check AM2 Fuse.
	<p>P Remove AM2 fuse from R/B No.2.</p> <p>C Check continuity of AM2 fuse.</p> <p>OK Continuity</p>
OK	NG Check for short in the harness and all the components connected to AM2 fuse.

Check and repair harness or connector between engine control module and battery.

3

Check for open in harness and connector between terminal E1, EO2 of ECM connector and body ground (See page IN-30).

OK

NG

Repair or replace harness or connector.

4

Check injectors.

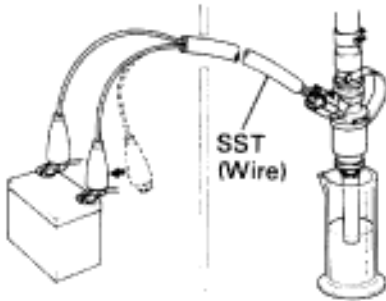
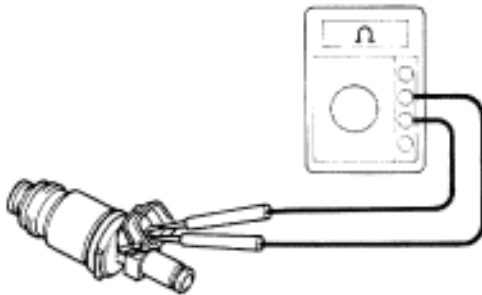
F16784
F14848

P

Disconnect injector connector. (See page EG-202)

C

Measure resistance of injector.

OK

Resistance: 13.4 — 14.2 Ω at 20°C (68°F)

C

Check injector volume of injector.
(See page EG-207)

OK

- Injection volume
70 — 88 cc/15 sec.
(4.3 — 5.4 cu in./15 sec.)
Difference between each injector:
Less than 9 cc (0.5 cu in.)
- Leakage
Fuel drop: One drip or less per minute

OK

NG

Replace injector.

Check and replace engine control module.

IAC Valve Circuit

CIRCUIT DESCRIPTION

The IAC valve is situated on the intake chamber. Intake air bypassing the throttle valve is directed to the IAC valve through a passage.

A step motor is built into the IAC valve. It consists of 4 coils, a magnetic rotor, valve shaft and valve.

When current flows to the coils due to signals from the ECM, the rotor turns and moves the valve shaft forward or backward, changing the clearance between the valve and the valve seat.

In this way the intake air volume bypassing the throttle valve is regulated, controlling the engine speed.

There are 125 possible positions to which the valve can be opened.

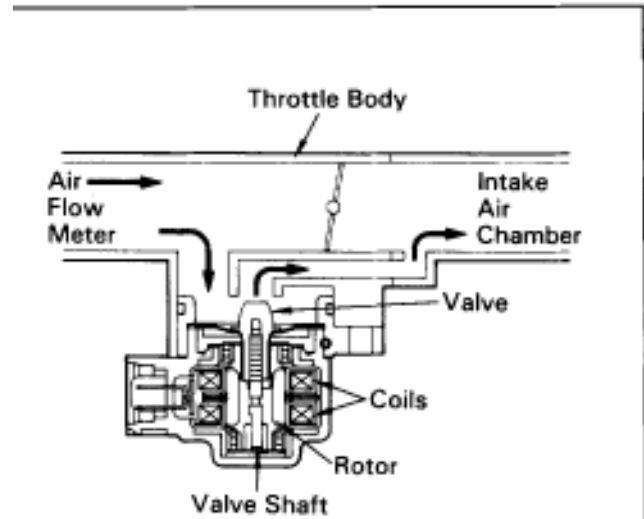
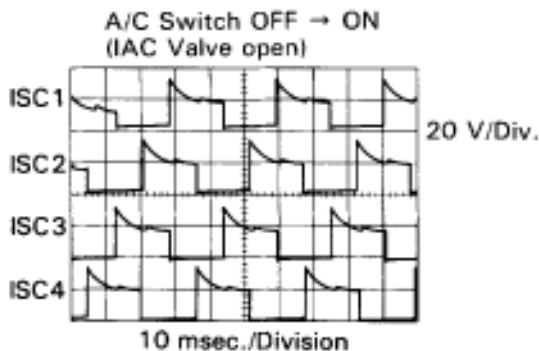

FIG111

Reference

INSPECTION USING OSCILLOSCOPE



- With the engine idling measure wave forms between terminals ISC1, ISC2, ISC3, ISC4 and E01 of engine control module when A/C switch ON or OFF.

HINT:

The correct waveforms are as shown.

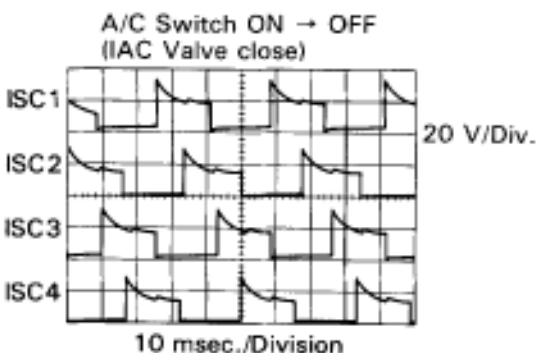

WIRING DIAGRAM

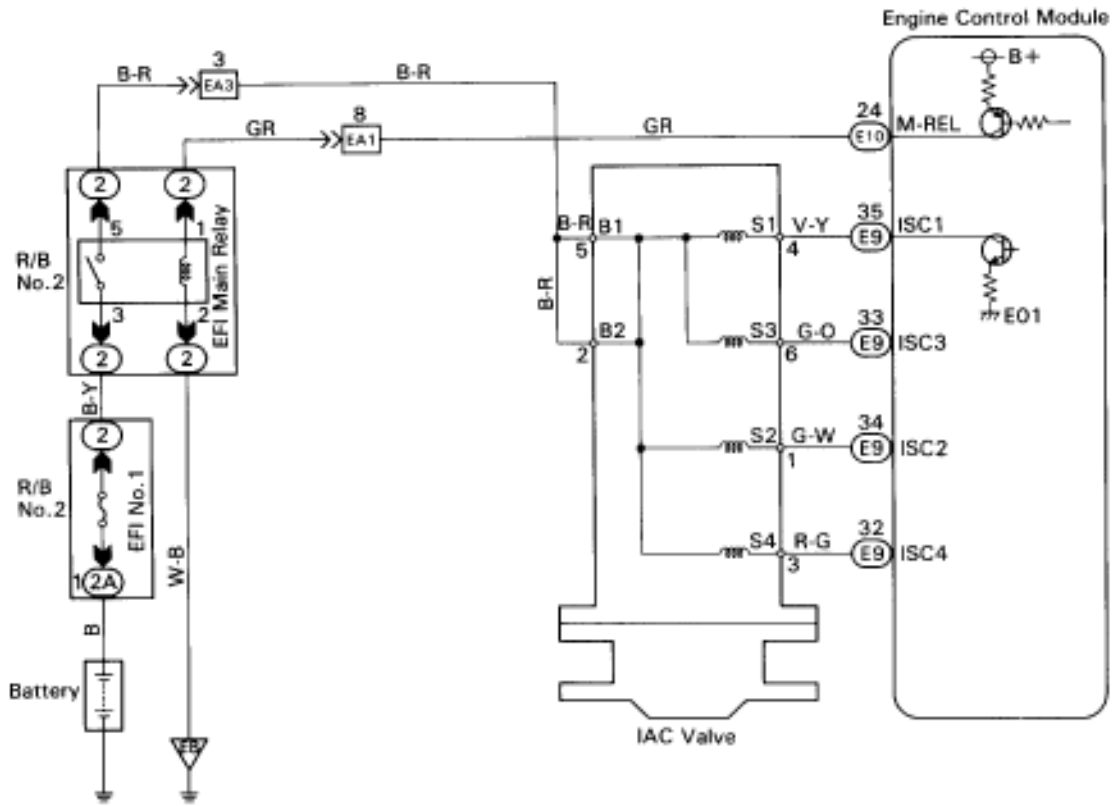

FI6935

INSPECTION PROCEDURE

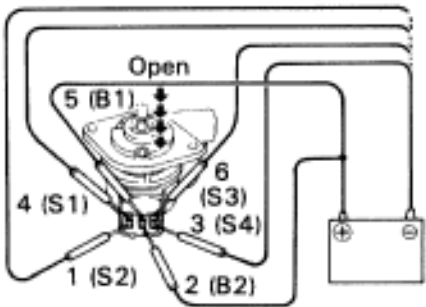
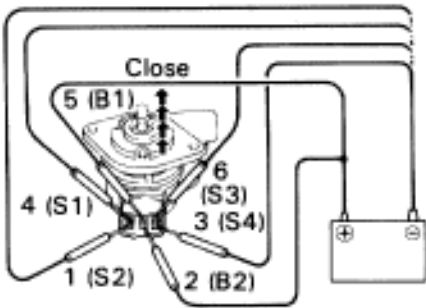
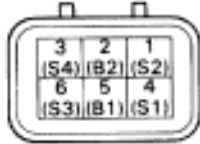
1**Check IAC valve.**F11694
P10701
P10700**P** Disconnect IAC valve connector.**C** Measure resistance between terminals shown below.**OK**

Terminal	Resistance
5 (B1) - 4 (S1)	10 Ω - 30 Ω
5 (B1) - 6 (S3)	10 Ω - 30 Ω
2 (B2) - 1 (S2)	10 Ω - 30 Ω
2 (B2) - 3 (S4)	10 Ω - 30 Ω

P Remove IAC valve.

- C**
- (1) Connect the battery positive lead to terminals 5 (B1) and 2 (B2), and the negative lead to terminals 4(S1)—1(S2)—6(S3)—3(S4) in that order.
 - (2) Connect the battery positive lead to terminals 5 (B1) and 2 (B2), and the negative lead to terminals 3(S4)—6(S3)—1(S2)—4(S1) in that order.

OK

- (1) The valve moves in the closing direction.
- (1) The valve moves in the opening direction.

OK**NG**

Replace IAC valve.

2**Check for open and short in harness and connector between EFI main relay and IAC valve, IAC valve and engine control module(See page IN-30).****OK****NG**

Repair or replace harness or connector.

Proceed to next circuit inspection shown on matrix chart (See page EG-408).

VSV Circuit for ACIS

CIRCUIT DESCRIPTION

The circuit opens and closes the IACV (Intake Air Control Valve) in response to the engine load in order to increase the intake efficiency (ACIS: Acoustic Control Induction System).

When the engine speed is 4,500 rpm or less and throttle valve opening angle is 30° or more, or engine speed is 4,500 rpm or more and throttle valve opening angle is 30° or less, the engine control module turns the VSV ON and closes the IACV. At all other times, the VSV is OFF, so the IACV is open.

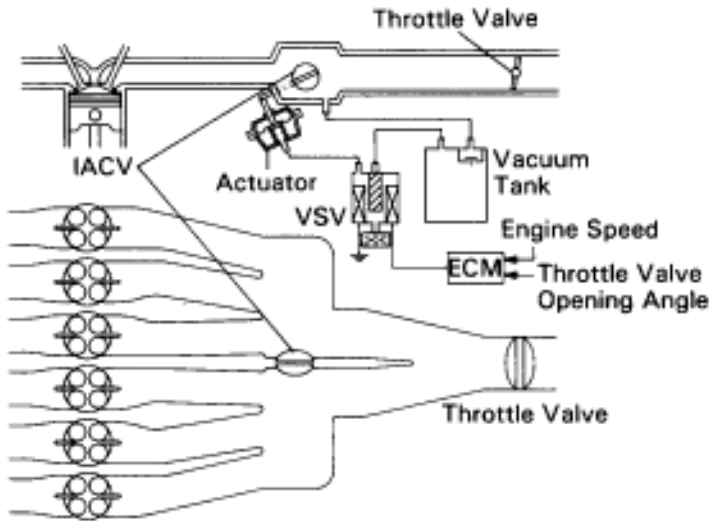

VSV	IACV
ON	closed
OFF	open

F16612

WIRING DIAGRAM

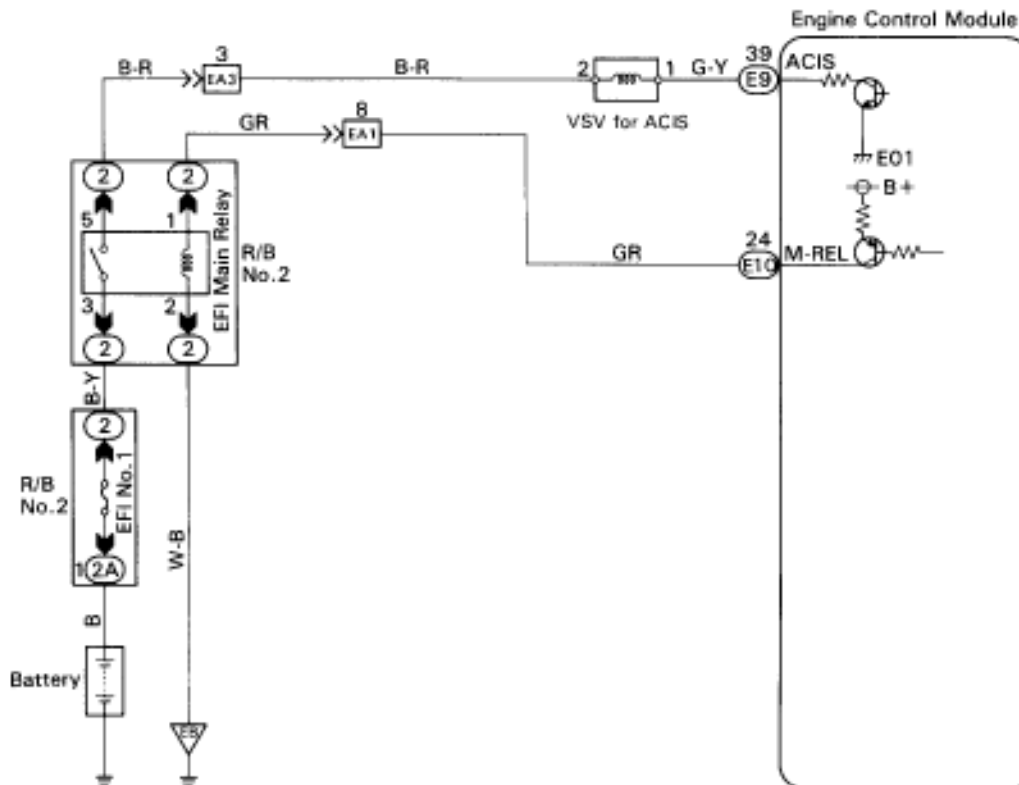

F16950

INSPECTION PROCEDURE

1

Check VSV for ACIS.

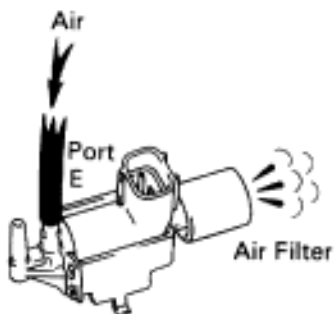
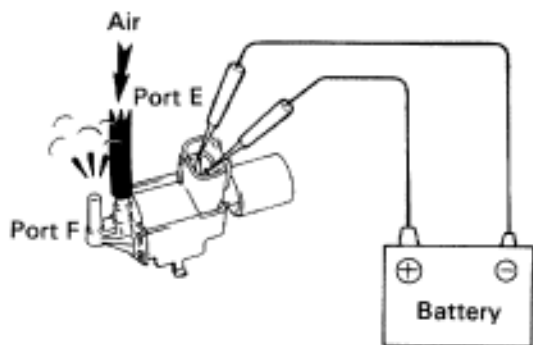
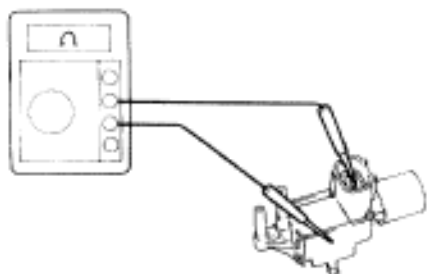
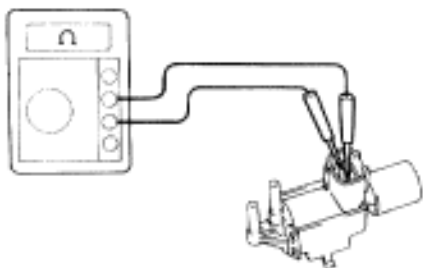

F15545
F15546
P02590
P02589

- P** (1) Remove VSV.
(2) Disconnect VSV connector.
- C** (1) Measure resistance between terminals.
(2) Measure resistance between each terminal and the body.
- OK** (1) Resistance: 38.5 — 44.5 Ω at 20°C (68°F)
(2) Resistance: 1 M Ω or higher

- C** Check operation of VSV when battery positive voltage is applied and released to the VSV terminals.

- OK** Battery positive voltage is applied:
Air from port E is flowing out through port F.

Battery positive voltage is not applied:
Air from port E is flowing out through the air filter.

OK

NG Replace VSV for ACIS.

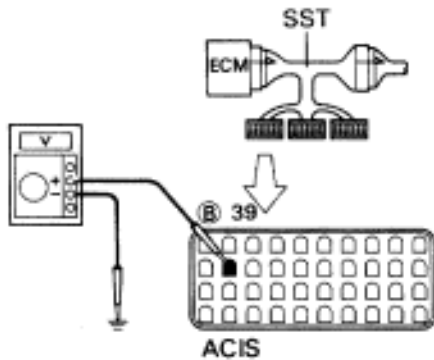
2**Check voltage between terminal ACIS of engine control module connector and body ground.**ON
BT6653
FM896

P (1) Connect SST (check harness "A").
(See page [EG-404](#))
SST 09990-01000
(2) Turn ignition switch ON.

C Measure voltage between terminal ACIS of engine control module connector and body ground.

OK Voltage: 9 — 14 V

NG

OK Check for vacuum tank. (See page [EG-230](#))

3**Check for open and short in harness and connector between EFI main relay and engine control module (See page [IN-30](#)).****OK**

NG Repair or replace harness or connector.

Check and replace engine control module.

VSV Circuit for Fuel Pressure Control (Only for California spec.)

CIRCUIT DESCRIPTION

The ECM turns on a VSV (Vacuum Switching Valve) to draw air into the diaphragm chamber of the pressure regulator if it detects that the temperature of the engine coolant is too high during engine starting.

The air drawn into the chamber increases the fuel pressure to prevent fuel vapor lock at high engine temperature in order to help the engine start when it is warm.

Fuel pressure control ends approx. 120 sec. after then engine is started.

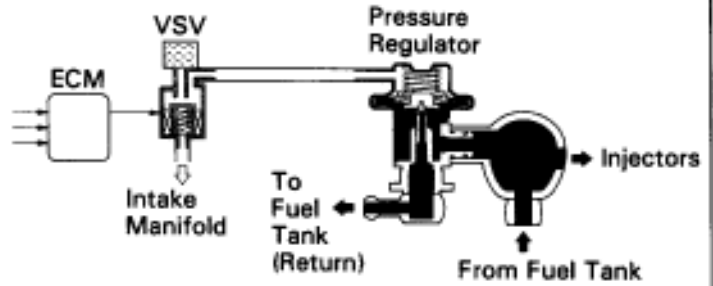

FI8897

WIRING DIAGRAM

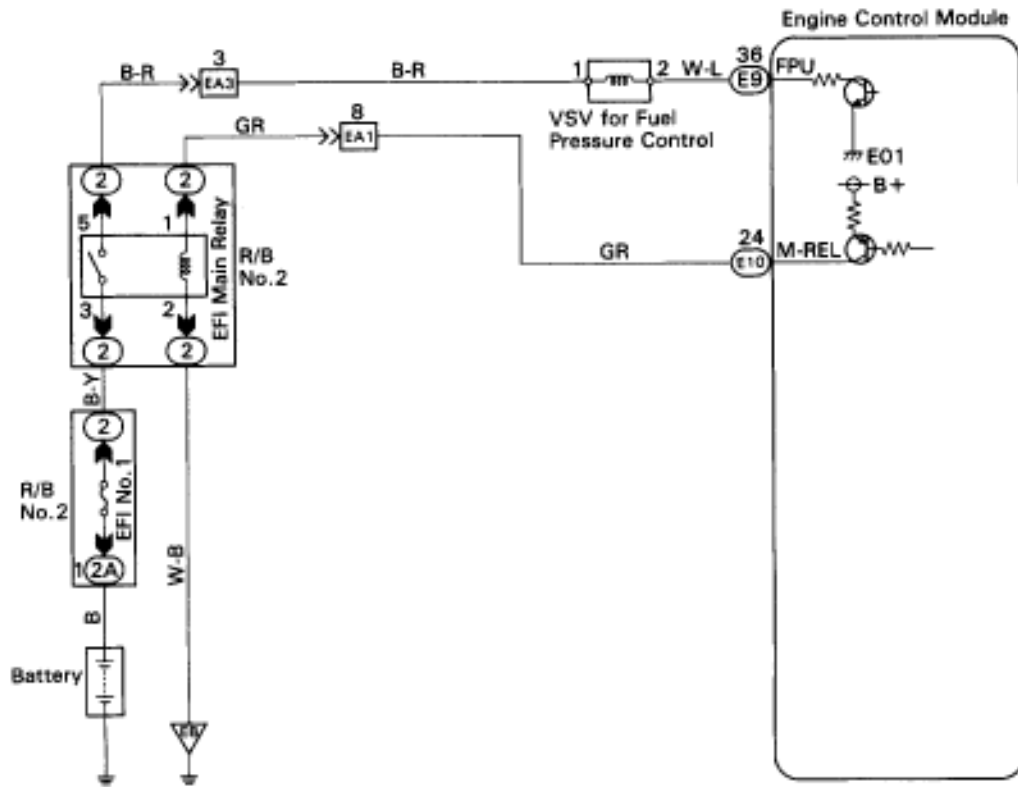

FI8950

INSPECTION PROCEDURE

1

Check VSV for fuel pressure control.

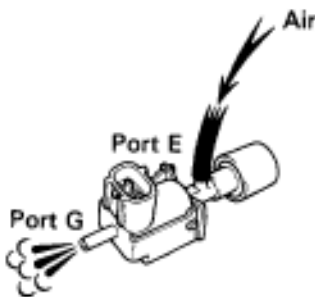
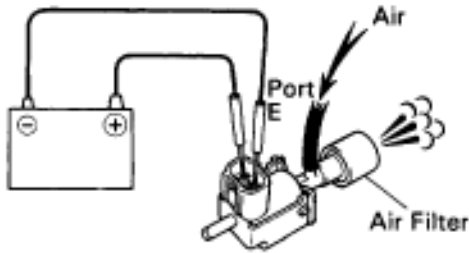
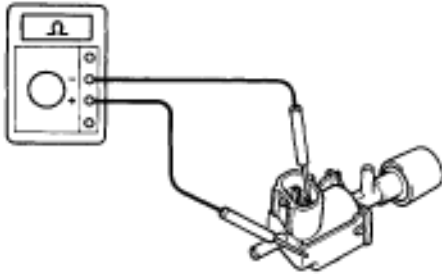
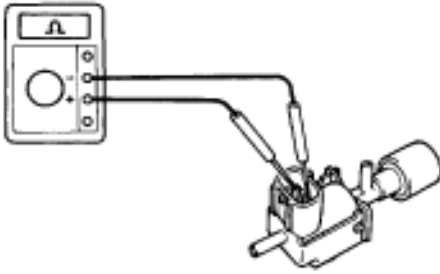

P10486
P10487
P10488
P10485

P

- (1) Remove VSV.
- (2) Disconnect VSV connector.

C

- (1) Measure resistance between terminals.
- (2) Measure resistance between each terminal and the body.

OK

- (1) Resistance: 33 — 39 Ω at 20°C (68°F)
- (2) Resistance: 1 M Ω or higher

C

Check operation of VSV when battery positive voltage is applied and released to the VSV terminals.

OK

Battery positive voltage is applied:
Air from port E is flowing out through the air filter.

Battery positive voltage is not applied:
Air from port E is flowing out through port G.

OK**NG**

Replace VSV for fuel pressure control.

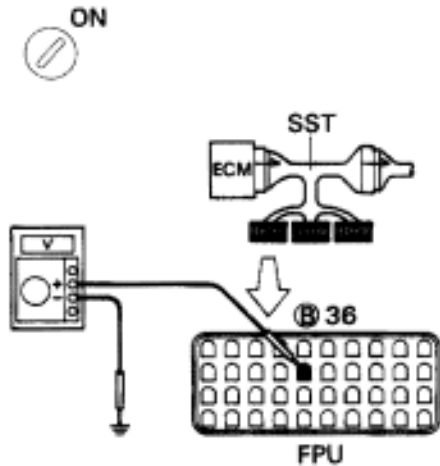
2**Check voltage between terminal FPU of engine control module connector and body ground.**BE6653
F18892

- P** (1) Connect SST (check harness "A").
(See page [EG-404](#))
SST 09990-01000
(2) Turn ignition switch ON.
- C** Measure voltage between terminal FPU of engine control module connector and body ground.
- OK** Voltage: 9 — 14 V

NG**OK**Proceed to next circuit inspection shown on matrix chart (See page [EG-408](#)).**3****Check for open and short in harness and connector between engine control module and VSV, VSV and EFI main relay (See page [IN-30](#)).****OK****NG**

Repair or replace harness or connector.

Check and replace engine control module.

TE1 TE2 Terminal Circuit

CIRCUIT DESCRIPTION

Terminal TE1 is located in data link connectors 1 and 2. Terminal TE2 is located ONLY in data link connector 2.

The data link connector 1 is located in the engine compartment and the data link connector 2 is located in the cabin. When these terminals are connected with the E1 terminal, diagnostic trouble codes in normal mode or test mode can be read from the malfunction indicator lamp on the telltale light RH.

WIRING DIAGRAM

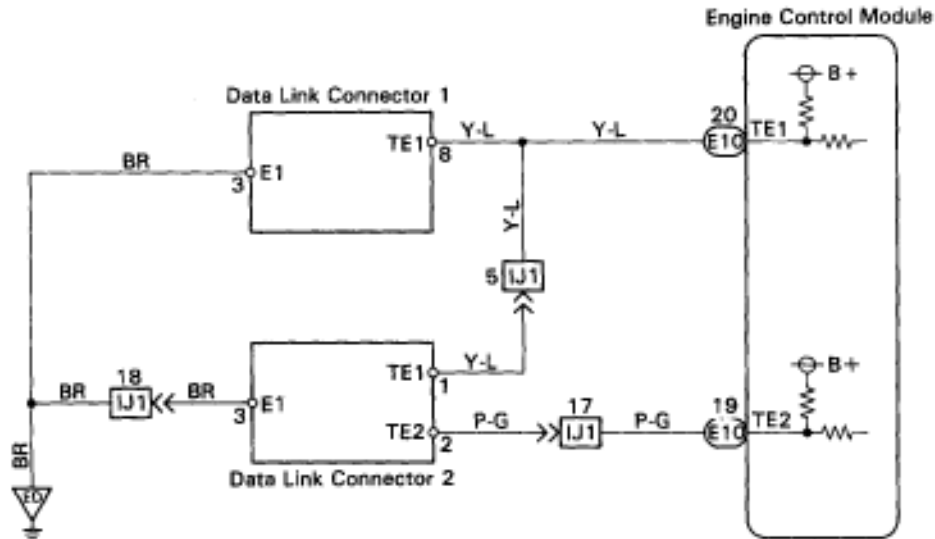

F16951

INSPECTION PROCEDURE

HINT: If terminals TE1 and TE2 are connected with terminal E1, diagnostic trouble code is not output or test mode is not activated.

Even though terminal TE1 is not connected with terminal E1, the malfunction indicator lamp blinks.

For the above phenomenon, the likely cause is an open or short in the wire harness, or malfunction inside the ECM.

1	Check voltage between terminals TE1, TE2 and E1 of data link connectors 1 and 2.
<p>ON</p> <p>BE6853 F16966 F14412</p>	<p>P Turn ignition switch ON.</p> <p>C (1) For DLC1, measure voltage between terminal TE1 and E1. (2) For DLC2, measure voltage between terminals TE1, TE2 and E1.</p> <p>OK Voltage: 9 — 14 V</p>
<p>NG</p>	<p>OK Check and replace engine control module.</p>
2	Check continuity between terminal E1 of data link connectors 1, 2 and body ground.
<p>OK</p>	<p>NG Repair or replace harness or connector.</p>
3	Check for open and short in harness and connector between engine control module and data link connectors 1, 2 (See page IN-30).
<p>OK</p>	<p>NG Repair or replace harness or connector.</p>
<p>Check and replace engine control module.</p>	