

**SBC** *i-Color*  
MULTI FUNCTION & FULL COLOR DISPLAY

**MMD** *i-Color*  
MULTI FUNCTION & MULTI ANGLE DISPLAY

## INSTALLATION MANUAL

*i-Color* Series



# BLITZ

WARNING: All images and text in this manual is the property of Blitz Performance Sales, Inc. No part of this maybe reproduced, stored in retrieval systems, or transmitted in any form or means without prior written permission of Blitz Performance Sales, Inc.

**First of all**

Thank you very much for purchasing this product. In order to use this product correctly and safely, please be sure to read this instructions manual thoroughly.

**Advice**

This manual is for the i-Color series. Keep in mind that there are parts of the manual where the SBC and MMD overlaps.

**SBC i-Color**

This product's purpose is to control the boost of the turbocharger and improve the output of the engine. A state of the art digital controller for an accurate gain in boost pressure, which controls two highly efficient sequential solenoids, achieves a minimum over shoot on peak boost and a stable boost pressure.

**Features of the product**

- Boost control & power meter function.  
An added function, the Result graph, which displays the results of power, torque, boost, and A/F overlapping to each other on one screen. It has a function as al logger according to the RPM to compare a maximum of three channels on the horizontal axis that are power, torque, boost and A/F.
- The ultimate boost controller  
The known full auto function evolves further in the SBC i-D series. A still more precise control is added to the auto boost setup. In addition to the new full auto function in which the self-learning method can be chosen in three steps, a boost according to the RPM and speed is possible to setup to match on all the stages.
- Full color (65.000 colors)  
The graphics that the full color display made it possible are; such as displaying from analog to digital meter, graph comparison display and a possibility to produce a variation of back ground images. If the optional TEMP sensor and PRESS sensor are connected, it is also possible to display water temperature or oil temperature and oil pressure.

Optional Sensor:           CODE 19210 Temp Sensor Set USD 130.00  
   CODE 19211 Press Sensor Set USD 130.00

### Monitoring functions

#### - Digital display:

A total of 12 data (Boost, Tacho, Speed, Power, Temp (Oil/Water), Fuel Press, Oil Press, Data 1 ~3 (A separate harness is necessary) can be monitored and it can display simultaneously on screen a maximum of six data.

※A/F can be displayed at the AUX port or at the external voltage port Data 1~3.

※The sensors are necessary to purchase separately.

#### - Analog display:

The Boost, Tacho, Speed, Power, Temp (Oil/Water), A/F, Fuel Press and Oil Press are reproduced as an analog meter image at the LCD. It can monitor a maximum of 4 data, including the digital displays at the screen, and the boost set up is at will. Moreover, the background can also be chosen from a white, black, carbon, and blue.

#### - Multi-angle display function

The display of the LCD can be set as left, right and perpendicular (the LCD at the top) operation angles. By selecting any one of these three angles, the switches also change automatically to the related angle.

#### - Convenient functions

It has a full load of convenient functions, such as a peak display, independent warning setup by source, maximum of 10 minutes of record/replay function (replay function can convert the unit displayed), back light adjustment, dimmer function, contrast adjustment and language selection.

#### Optional A/F display function

If the optional A/F amplifier unit is connected, the A/F ratio can be measured and monitored, which can compare with boost or other sources. Thus, the boost setting can be broadened.

### Regarding the boost controller

#### - Sequential valve control:

Two-solenoid valves operate sequentially depending on the valve-open ratio. Mainly, the first valve will do most of the work at low valve-open ratio and at high valve-open ratio; the second valve will come to play.

#### - Automatic correction of boost pressure (Initial learning):

It will automatically correct to the desired boost pressure that has been configured. A C mark will change color from RED to WHITE when the correction cycle (DUTY value) reaches the desired value. While the C mark is lighted, the SCRAMBLE MODE or the SPEED MAP MODE will not take effect on the used channel. However, the boost control will take effect even if the C mark does not change to WHITE color. This time, to perform the initial learning smoother, the normal, mild and slow function has been added. The Automatic correction of boost pressure is not applicable on manual mode.

**Advice**

When on Full Auto Mode for the first time, it will start setting from the original boost pressure in a numbers of attempts. However, if full boost is not reached while setting (Ex: half throttle), it could cause an over shoot right after the failed attempt because it is over correcting the value of the Duty Cycle. We recommend setting the boost limiter [Warning] before configuring to the desired boost.

**External voltage input**

It is possible to display, record, and replay by inputting an external voltage of 0-16V up to three channels. It is possible to change the voltage scale from -999~9999. It is also possible to arbitrary setup the value. Therefore, it can be used to record the throttle voltage, airflow voltage, water temp and replay for reference as a setting tool. The external voltage input harness is sole separately.

Product name:	External voltage input harness
Product number:	15053
Manufacturers suggested price:	USD 45.00
Function:	It can display external voltage source of 0~16V by taking it to the boost controller.

### **MMD i-Color**

Since it is actually calculated on the road, a more accurate reading can be achieved by measuring factors such as frictional resistance from the road surface, angle (slope) of the road, air resistance and so on. It is capable to measure a maximum of 1200 PS.

#### **Features of the product**

##### - Power meter function

It measures and displays the horsepower and torque of the vehicle. Of course, the peak hold and the warning function are also available. At the chassis dynamo measurement function, the chassis dynamo graph can be easily displayed. A selection of PS (0~1200PS) or KW (0~882KW) can be selected for power measurement. Moreover, a result function to display overlapping the power, torque and A/F curve in one screen has been added. It also has a function as data logger, which can display graphically up to three channels to compare the horizontal axis of power, torque and A/F ratio according to the RPM.

#### **Advice**

This product computes the horsepower on the actual workload that the tires are performing on the road based on the weight of the vehicle and speed. Therefore, the actual value (Net horsepower) might be different from the released value of the automaker and on each engine. Since it computes by actually driving on the road, it displays the actual horsepower by computing the engine's performance at the point in time minus the various resistances such as the rolling resistance, air resistance, drive train resistance, etc.

#### **Full color (65,000 colors)**

The full color LCD can display from digital, analog and graphical meter. The graphical meter can be use for comparison and many other ways to display the background. It can also display the water temperature, oil temperature, fuel pressure and (or) oil pressure by acquiring the optional Temperature sensor and (or) Pressure sensor.

Optional Sensors:	CODE 19210 Temp Sensor Set USD 130.00
	CODE 19211 Press Sensor Set USD 130.000

#### **Monitoring functions**

##### Digital display:

It can display simultaneously up to 6 data out of the 11 data which are the TACHO, SPEED, POWER, TEMP (oil/water), FUEL PRESS, OIL PRESS, AUX, DATA1~3 (Optional external voltage input harness needed)

The A/F ratio can be displayed through the AUX port or the DATA 1~3 external voltage input port.

The sensors have to be acquired separately.

### **Analog display**

The TACHO, SPEED, POWER, TEMP (oil/water), FUEL PRESS, OIL PRESS can be displayed as an analog meter. It can monitor up to 4 data including the digitally displayed values on the LCD screen and the source of the data can be displayed many ways. Moreover, the color of the background can be chosen from white, black, carbon and blue.

### **Multi angle display**

The buttons are automatically reconfigured by switching the display direction of the LCD as left, right and up.

### **Convenient functions**

Peak display, warning configuration on each source, max 10 minutes recording, replay, displayed unit change, dinner, contrast adjustment, English, Japanese, etc

By purchasing the optional A/F meter, it can also display, monitor and record the fuel ratio comparing with other data sources to broaden the setting of the A/F ratio.

### **Upgrading the SBC i-D**

Those owning the Blitz SBC i-D series can easily upgrade to the full color display by attaching the MMD. The functions will be the same as the SBC i-Color. ※The unit of the boost will be automatically set as hkpa.



## Safety Notice

In order to use the product safely, please read the "SAFETY NOTICE" thoroughly.

### Explanation of warning symbols

**DANGER:** Ignoring these indications may cause serious injuries or even death to the individual and (or) to a third party.

**CAUTION:** Ignoring these indications may cause serious injuries or injuries to the individual and (or) to a third party.

**ATTENTION:** Ignoring these indications may cause injuries or minor injuries to the individual and (or) to a third party. It may also cause malfunctions and breakages to the product and (or) to the vehicle.

### Please read carefully and understand the contents.

- This product is manufactured for vehicles used in circuits and closed courses.
- Notes on "how to use this product" and "installation procedures" are explained in detail in this manual.
- Blitz Co., Ltd and Blitz Performance Sales, Inc will not be responsible of any breakage and malfunctions caused in installing this product with a vehicle installed with a third party's product(s) and with a reconstructed vehicle.
- Blitz Co., Ltd and Blitz Performance Sales, Inc will not be responsible of any breakage, malfunctions and liabilities caused by wrong installation and usage.
- This product and its accessories may be changed without announcement for improvements.

### CAUTION:

- **Install this product at a well-ventilated area.**

Ignoring this indication may cause a fire and (or) an explosion.

- **Install this product and its parts firmly at a secured place that would not be of any interference while driving.**

Ignoring this indication would cause an accident.

- **This product is designed to work on 12V DC, and the ground is designed to be the chassis of the car.**

It would cause a fire by installing this product other than a vehicle powered by a 12V DC

- **Disconnect the ground line from the battery while installing this product.**

It would cause a fire by an electric short, breakage of electronic part(s) and (or) burn(s).

- **Disconnect the harness's connectors from the connectors it self. DO NOT pull from the harness.**

It would cause a fire by an electric short, breakage of electronic part(s) and (or) burn(s).  
Moreover, it would cause some malfunction(s) to this product.

- **Discontinue utilizing this product and contact our retailers or us, if you notice some irregular noise and (or) odor from this product.**

By disregarding this (these) symptom(s), it would cause a fire, electrocution, and (or) breakage of electronic part(s).

- **DO NOT operate this product while driving.**

It would cause an accident.

- **DO NOT damage any wiring(s) and (or) piping(s) from the engine room while installing this product.**

It would cause a fire by an electric short, breakage to the engine, vehicle and (or) to the electronic part(s). Insulate the unnecessary wiring(s) for the installation.

#### **ATTENTION:**

- **About the LCD screen.**

The LCD screen may seem dark or distorted if seen through polarized sunglasses.

- **Ask for a professional or a technician to perform the installation of this product.**

The individual performing this installation must have technical skills and knowledge to perform this installation.

- **Do not drop or insert extreme force to the product while installing it.**

It would cause malfunctions.

- **Do not misuse, abuse, alter, take apart and (or) modify this product in any way.**

It would cause an accident, fire, electrocution, and breakage and (or) burn the electronic parts. If any of the above indications are executed, the warranty of the product will be voided.

- **Do not install this product at a location where it could get wet and (or) highly heated.**

It would cause an electrocution, fire, breakage and (or) burns to the electronic components.

- **Does not heat the LCD screen over 60 degrees Celsius (140 degrees Fahrenheit) for a long period.**

It would cause the LCD screen to go black.

- **Do not install this product while the engine and its components are hot; wait until they are fully cooled.**

It would cause burn(s) to you or to a third party if the engine, radiator, and the exhaust system were still hot.

- **Please perform regular maintenance and be extra cautious.**

This product's durability and components are thoroughly tested; however, depending on the vehicle's driven condition and (or) climate, the durability may decrease.

- **Do not throw away the original detached components from the vehicle. Please keep the**



components securely.

We are not liable from any damages caused to the components while installing it. Please be extra careful through the installation.

- Use the right tools to tighten the nuts and bolts.

It will damage the threads if you over tighten it or by using the wrong tools.

- This product has been designed and tested on vehicles with manufacturer's original components.

It would cause malfunctions to the product or vehicle if you have already installed a third party's product(s).

**CAUTION:**

- Be fully careful when selecting the type turbo exhaust gas bypass.

There are actuator types and waste gate types. If the selection is mistaken, it may lead to breakage of the turbo, engine, and the vehicle itself.











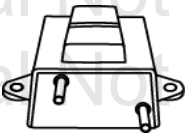
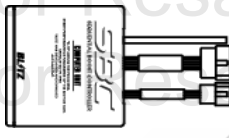

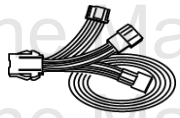

- Do not over boost.

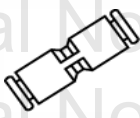
Blitz Co., Ltd and Blitz Performance Sales, Inc will not be responsible of any breakages to the turbo caused by over boosting (Over Boosting).

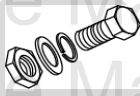
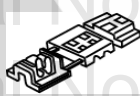





- Do not perform operational checks and boost setups while driving on a public road.

The distraction from the operation may cause an accident.

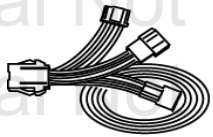
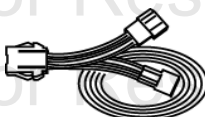
**SBC i-Color parts list. (Check for all components)**

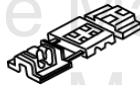
Color LCD Display 1Pc 	Sequential Valve Unit 1Pc 	CPU Unit 1Pc 	Main Harness 1Pc 
Center Harness (for SBC) 1Pc 	$\phi$ 4- $\phi$ 6 Straight Joint 2Pc 	Joint Pipe 1Pc 	$\phi$ 6 Three Way 1Pc 
$\phi$ 6 Clamp 6Pc 	$\phi$ 4 Hose Joint 1Pc 	2M $\phi$ 6 Hose 1Pc 	2M $\phi$ 4 Nylon Tube 1Pc 
M6 Bolt & Nut Set 2Pc 	Electro Tap 4Pc 	Lock Tight 6Pc 	Display Back Seal 1Pc 
Double Sided Tape (50 X 15) 2Pc 	Double Sided Tape (50 X 30) 1Pc 	Instruction Manual 1Pc 	Wiring Manual 1Pc 

**MMD i-Color parts list. (Check for all components)**

<p>Color LCD Display 1Pc</p>	<p>Center Harness (for SBC) 1Pc</p>	<p>Center Harness (for MMD) 1Pc</p>	<p>Wiring Terminal Set 1Set</p>
			
<p>Electro Tap 2Pc</p>	<p>Double Sided Tape (50 X 15) 1Pc</p>	<p>Display Back Seal 1Pc</p>	<p>Instruction Manual 1Pc</p>
			
<p>Wiring Manual 1Pc</p>			
			

1. Display Unit.

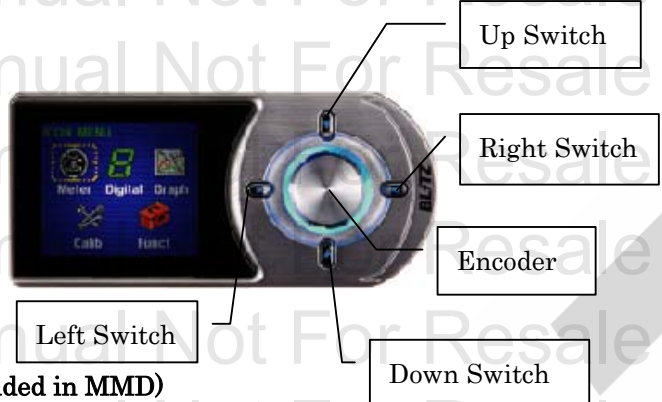

2. CPU Unit. (Not included in MMD)

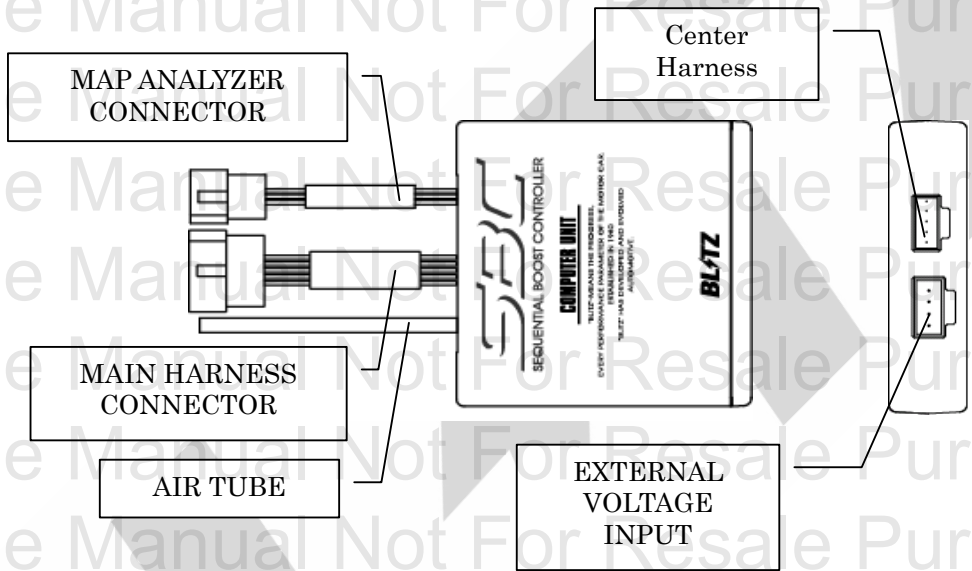

3. Sequential Valve Unit. (Not included in MMD)

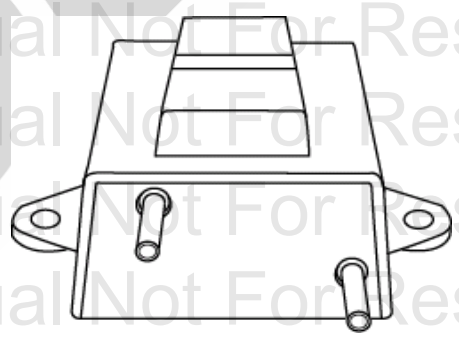

#### 4. Harnesses and Connections.

SBC i-Color:

5P Harness → Connect to the Main Harness

3P Harness → Connect to the MAP Analyzer (Sold Separately)

Φ4 Nylon Tube → Connect to the surge tank or a location that generates vacuum at throttle OFF.

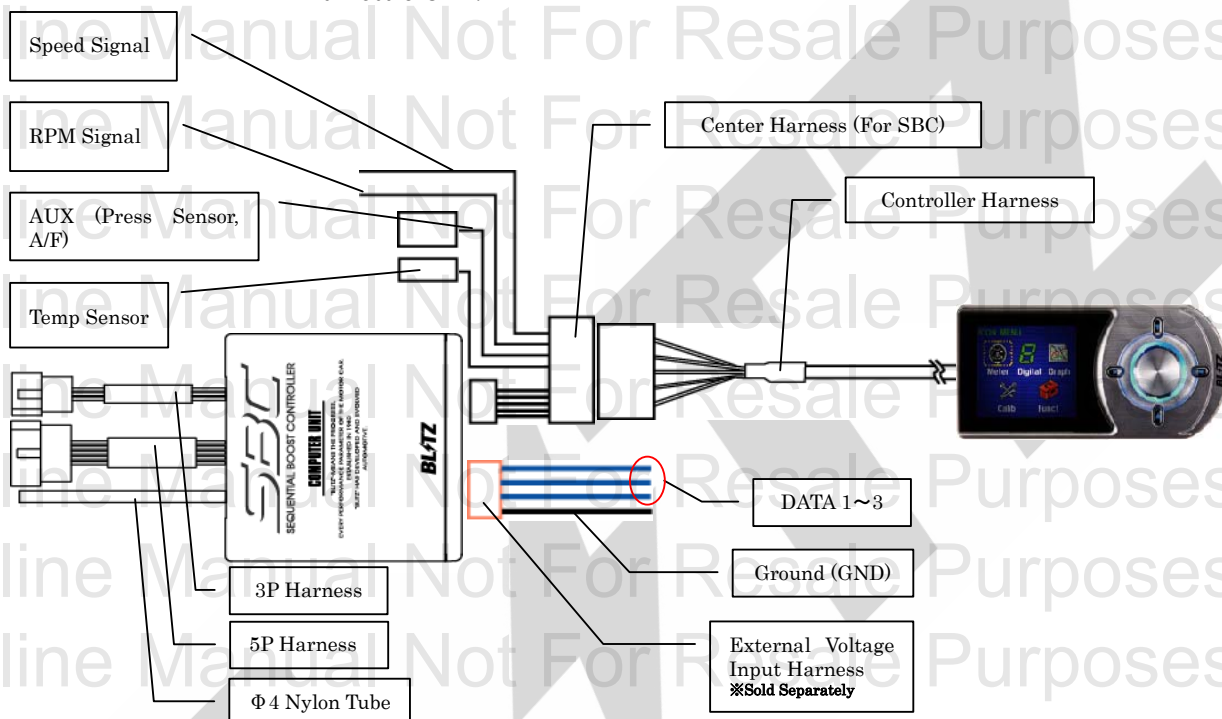

MMD i-Color:

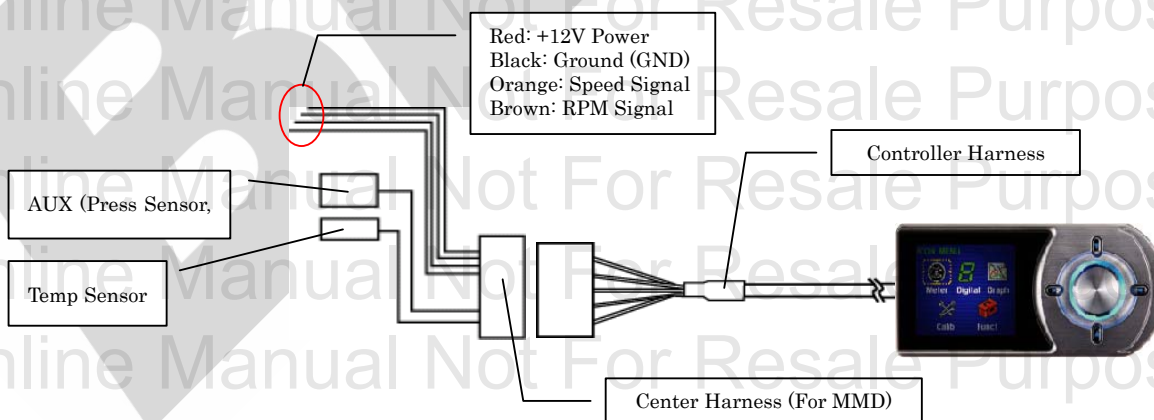

#### Advice

Refer to the attached ECU wiring diagram for more information.





### Piping methods to the Sequential Valve Unit.

#### Actuator (Swing Valve) Type.

1. Make sure the valve type is set as actuator type (AC) at the controller's function menu.
2. Cut the actuator's hose and connect it to the OUT line of the solenoid valve unit.
3. Cut the turbo's hose and connect it to the IN line of the solenoid valve unit.

Single Turbo:

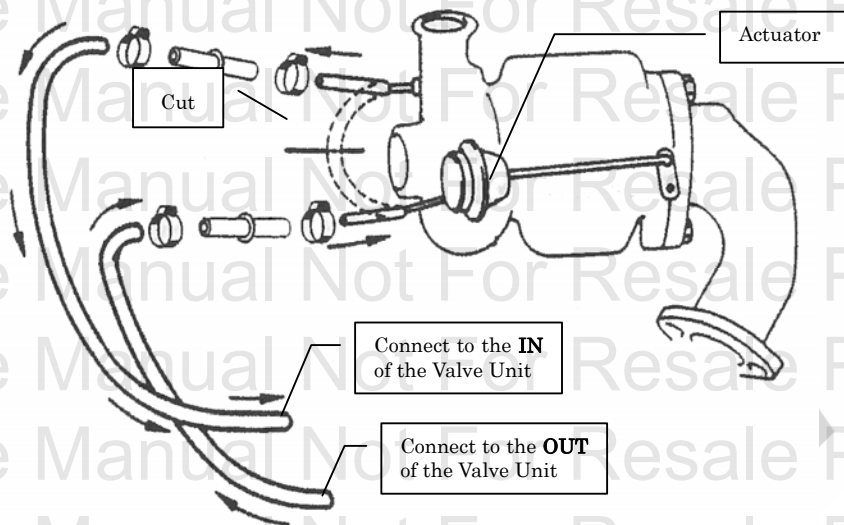

Twin Turbo:

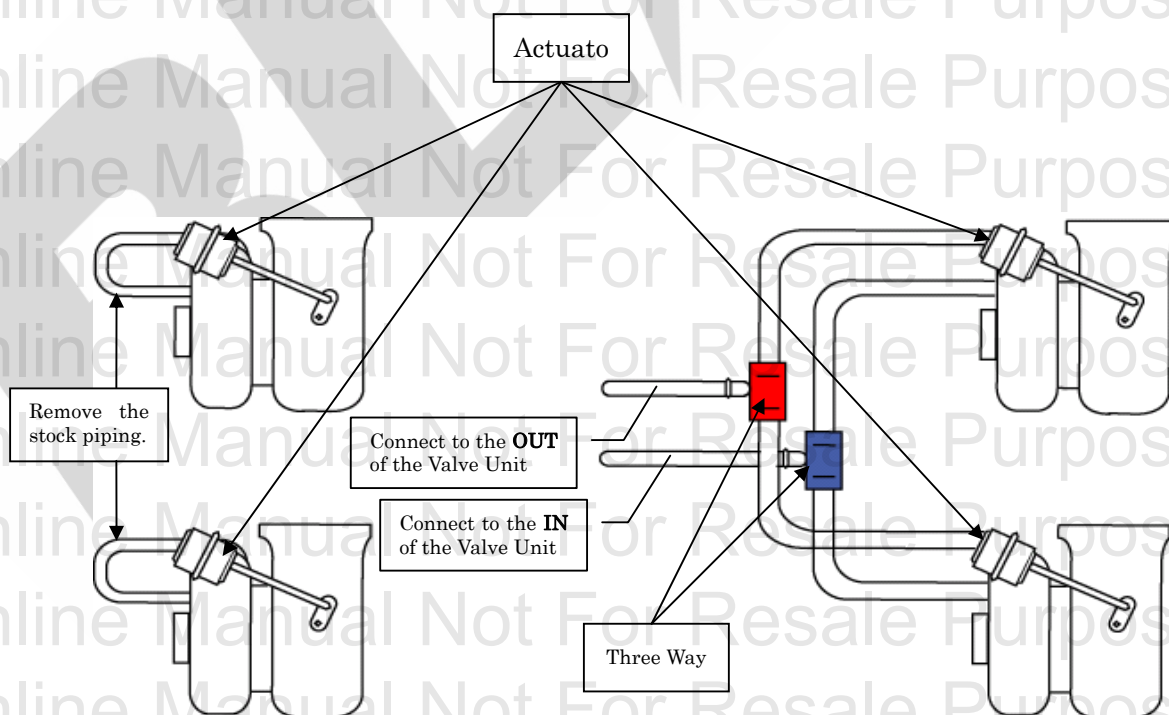

**A Solenoid valve control systems that are common on Nissan and Mitsubishi vehicles.**

Please remove and plug the hosing that goes to the Solenoid valve, or return it to the suction pipe, but in some cases plug the suction pipe itself.

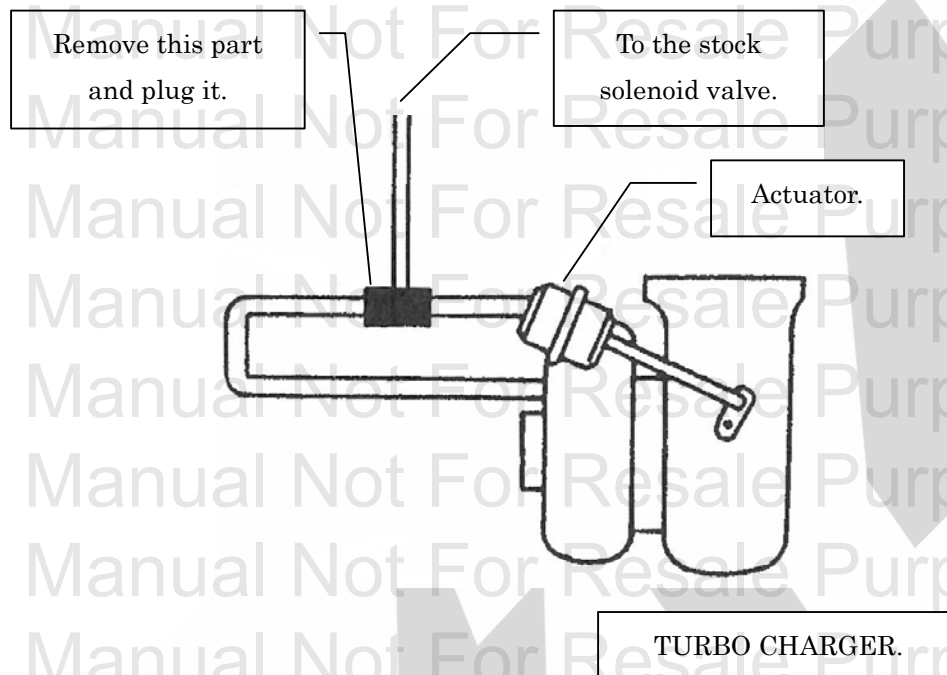

**A two-mode control systems that are common on Toyota vehicles.**

Please remove the hose that goes to the Solenoid valve and plug both the actuator and the solenoid side.

Please do not remove the connector to the solenoid valve. There are vehicles that the engine check lamp might turn on.

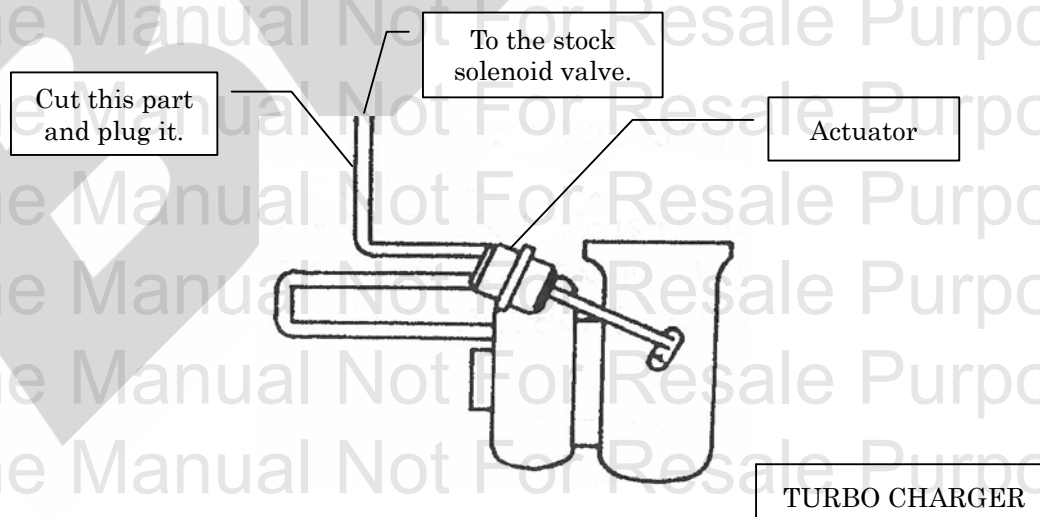

### Waste Gate Type.

1. Make sure the valve type is set as waste gate type (WG) at the controller's function menu.
2. Take the boost pressure between the turbocharger's compressor cover and the throttle valve and connect it to the IN of the solenoid valve unit. Make sure to use the clamps supplied with the kit.
3. Moreover, the same boost pressure (compressor cover and the throttle valve) must be connected to the B chamber (Lower chamber) of the Waste Gate. Make sure to use the clamps supplied with the kit.
4. Connect the OUT of the solenoid valve unit to the A chamber (Upper chamber) of the Waste Gate. Make sure to use the clamps supplied with the kit.

Note: If you have a TIAL, Turbonetics or other domestic manufacturer external waste gate using the A/C setting may provide more accurate control.

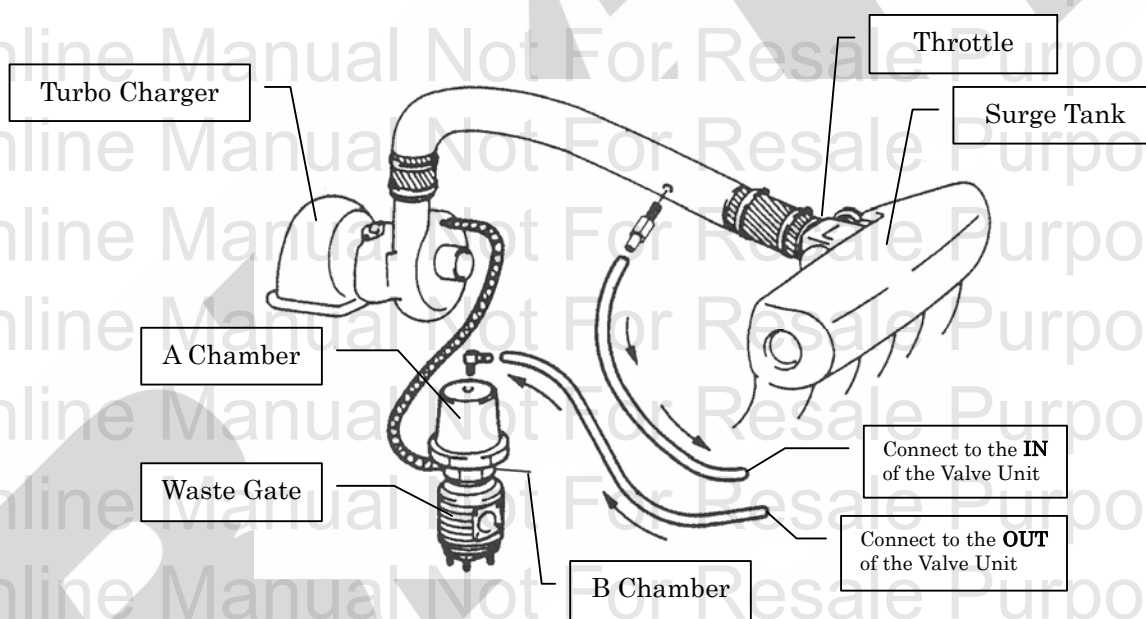

## Installation of the SBC i-Color LCD Display

Steps:

- 1) Disconnect the battery.
- 2) Connect using the provided T pipe and  $\Phi 4$  nylon tube from a location where vacuum and boost can be acquired to the CPU unit's  $\Phi 4$  nylon tube.
- 3) Connect the valve unit connector to the main harness and wire in the main harness to the interior of the vehicle. Then connect the black wire (ground) and the red wire (power). The red wire must be connected to a power source that can supply +12 at IGN-ON.

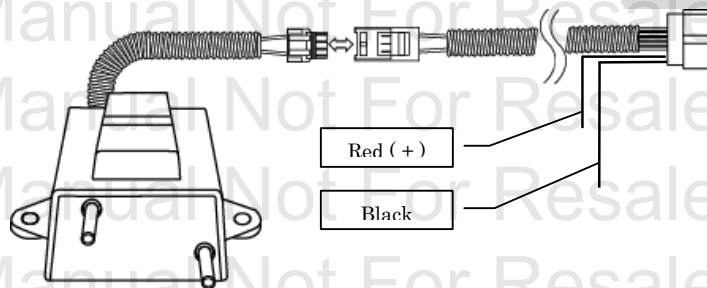

- 4) Connect the harness from the LCD Display to the center harness and connect the center harness to the CPU unit.
- 5) Using an electro taps, connect the:
  - Orange wire: Vehicle speed
  - Brown wire: RPM
 (Take a look at the attached booklet for UCU wire diagrams)
- 6) Connection of optional sensors.  
 Connect the TEMP sensor, the PRESS sensor or the A/F sensor to the center harness. (Only the PRESS sensor or the A/F sensor can be connected to the AUX port)  
 If the PRESS sensor is connected to the AUX port, the A/F can be displayed through the External Voltage Input Harness. **※Sold Separately**
- 7) Install the LCD display at a location that would not interfere while driving. Moreover, bundle together all the wire with lock tights and double side tapes.
- 8) Normally the External voltage Input and the 3P harness remains unused.

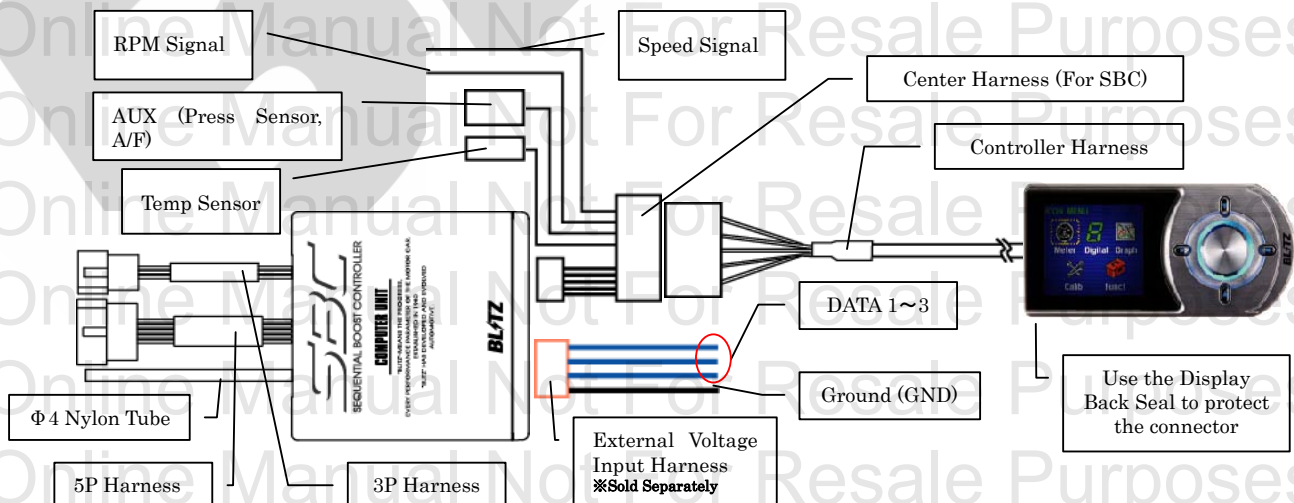

WARNING: All images and text in this manual is the property of Blitz Performance Sales, Inc. No part of this maybe reproduced, stored in retrieval systems, or transmitted in any form or means without prior written permission of Blitz Performance Sales, Inc.



## Installation of the MMD i-Color LCD Display

Steps:

- 1) Disconnect the battery.
- 2) Connect the harness from the LCD Display to the center harness and connect the center harness to the CPU unit. Then connect the black wire (ground) and the red wire (power). The red wire must be connected to a power source that can supply +12 at IGN-ON.
- 3) Using an electro taps, connect the:
  - Orange wire: Vehicle speed
  - Brown wire: RPM
 (Take a look at the attached booklet for UCU wire diagrams)
- 4) Connection of optional sensors.  
 Connect the TEMP sensor, the PRESS sensor or the A/F sensor to the center harness. (Only the PRESS sensor or the A/F sensor can be connected to the AUX port at once and the voltage (FIT Value) must be calibrated).  
 The TEMP sensor can be displayed just by plugging.
- 5) Install the LCD display at a location that would not interfere while driving. Moreover, bundle together all the wire with lock tights and double side tapes.

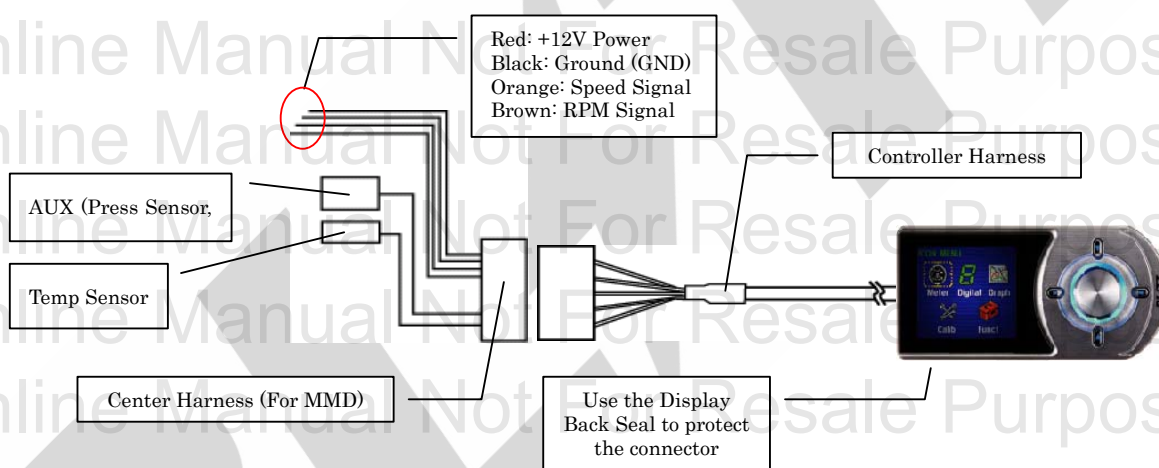

## Installation of MMD i-Color to the SBC i-D.

Instead of using the MMD i-Color's center harness; keep using the SBC i-D's center harness to install the MMD i-Color to the SBC i-D. All the functions and operations will be the same as the SBC i-Color. However, the displayed units will all be changed to hkpa.

## Initial Setting

Basic function. (First of all, carry out the initial setting at the function and calibration mode).

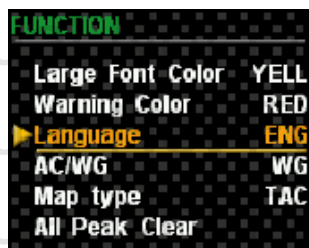
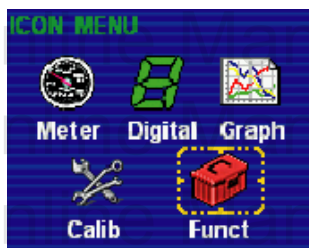

- 1) **Setting of language and type of exhaust gas bypass.**

Select "Funct" at the "ICON MENU" screen and then press the encoder.

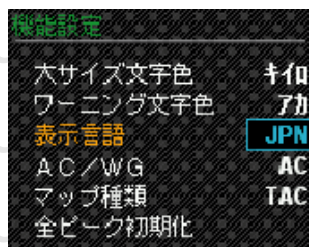

Turn the encoder to select the language. Press the encoder again to confirm.

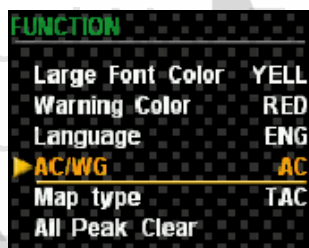

Follow the same steps to change the selection from AC (Actuator) or WG (Waste gate).

※ Be careful not to make mistakes in selecting the type of exhaust gas bypass since it might damage or break the engine.



- 2) **Setting of vehicle speed and RPM.**

Select "Calib" at the "ICON MENU" screen and then press the encoder.



To calibrate vehicle speed, select "SPEED CALIBRATION" and choose from the types of pulses (2, 4, 8 or 16), or select "Keep 40 km/h & Enter" to calibrate the speed pulse. (40 km/h is approximately 24.8 mph)



Follow the same steps to calibrate RPM, select "TACHO CALIBRATION" and choose from the numbers of cylinders (3, 4 or 6), or select "Keep 3000 RPM & Enter" to calibrate the RPM pulse.



3) **Vehicle weight, type of drive train, running resistance (Power Loss).**

The power meter calculates the horsepower by detecting the speed signal and acceleration. Therefore, the weight, type of drive train and road resistance area play big factors in calculating the horsepower as accurate as possible.

Vehicle weight setting

At the CALIBRATION screen, select "Power Calibration" then press the encoder.  
**Advice:** Input the weight as detailed as possible to obtain an accurate reading. EX: weight of the vehicle, driver, passenger, gas, etc. (If the weight of the vehicle is less, it will display less horsepower, and vice versa)



Drive train setting

Select from 2WD or 4WD. (Select 2WD on vehicles with torque split type 4WD such as the Skyline GTR)

Running resistance (Power Loss) setting

Select from -15 to 34 to compensate the losses incurred from air resistance and road resistance. (See the chart to input the resistance value for your particular type of vehicle)

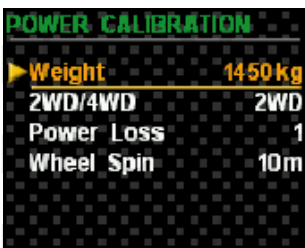

Wheel spin distance setting

Can be set from 0M to 50M.  
 It avoids abnormal reading caused from wheel spins at start up. (We recommend to set at 10M as shown in default)

Resistance Chart	
Vehicle Type	-2
Mini vans w/ a displacement of less than 1000 cc	-1
NA Vehicles from 1000 cc ~ 1600 cc	-2
Turbo Vehicles w/ a displacement of more than 1600 cc	0
Sport Vehicles w/ a displacement of more than 3000 cc	0
4 Door Sedan	2
Station Wagons	2
Mini Vans	3
SUV	5
RV	8



- 4) **Boost Set Up**  
 Select "Boost Setup" at the "CALIBRATION" screen and then press the encoder.

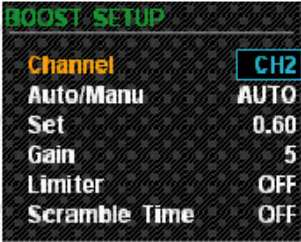

AUTO (Automatic boost set up)

4 different settings can be chosen from 4 different channels (CH). First choose a CH that would be set as the base CH.

Operation method:

Turn the encoder to select "Channel" and then press the encoder. Turn the encoder to select the CH (CH1~CH4) and then press the encoder on the desired CH to confirm.

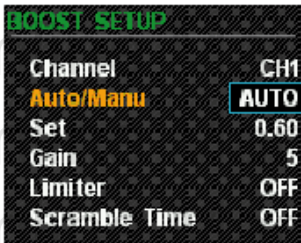

Select "AUTO" for automatic boost control.

Note: Automatic mode is not as accurate as the manual mode.

Operation method:

Same as "Channel" (shown above)

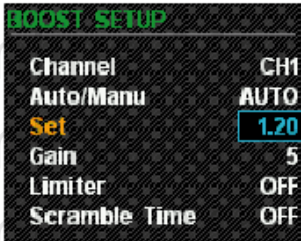

Input the desired boost value.

Units in hkpa from 0~2.45.

hkpa	kg/cm2	bar	a tm	mmHg	psi
1	1.02	1	0.987	750	14.5

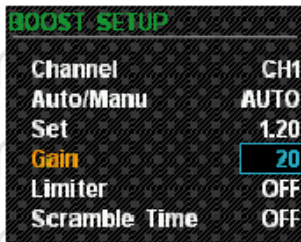

Input the desired GAIN value.

GAIN is the adjustment of boost response.

The larger the number, the faster the response of the boost and vice versa.

From 0 ~ 100.

We recommend setting the GAIN on:

Stock turbo: 15~25.

Sequential, ball bearing turbo: 5~15.



The limiter and scramble function will be explained later.

The initial setting will be OFF at this time.



BOOST SETUP	
▶ Channel	CH1
Auto/Manu	MANU
Set	45
Gain	25
Limiter	OFF
Scramble Time	OFF

#### MANU (Manual boost set up)

4 different settings can be chosen from 4 different channels (CH). First chose a CH that would be set as the base CH.

Operation method:

Turn the encoder to select "Channel" and then press the encoder. Turn the encoder to select the CH (CH1~CH4) and then press the encoder on the desired CH to confirm.

BOOST SETUP	
Channel	CH1
Auto/Manu	MANU
Set	45
Gain	25
Limiter	OFF
Scramble Time	OFF

Select "MANU" for manual boost control.

Operation method:

Same as "Channel" (shown above)

BOOST SETUP	
Channel	CH1
Auto/Manu	MANU
Set	45
Gain	25
Limiter	OFF
Scramble Time	OFF

Input the desired "Point" value.  
0 ~ 100 units.

#### Advice:

Point method represents the ratio between the normal boost pressures. It is not the direct value of the boost pressure. The point 0 represents the Max normal boost (boost pressure set by the manufacturer) and the point will go up to 100, which the boost pressure will keep rising up to the limit of the vehicle (the turbo) can handle.

**ATTENTION:** Ignoring these indications may cause injuries or minor injuries to the individual and (or) to a third party. It may also cause malfunctions and breakages to the product and (or) to the vehicle.

BOOST SETUP	
Channel	CH1
Auto/Manu	MANU
Set	45
Gain	25
Limiter	OFF
Scramble Time	OFF

Input the desired GAIN value.

GAIN is the adjustment of boost response.

The larger the number, the faster the response of the boost and vice versa.

From 0~100.

We recommend setting the GAIN on:

Stock turbo: 15~25.

Sequential, ball bearing turbo: 5~15.

Can be set at 25~+ if a faster response and overshooting is desired

BOOST SETUP	
Channel	CH1
Auto/Manu	MANU
Set	45
Gain	25
Limiter	OFF
Scramble Time	OFF

The limiter and scramble function will be explained later.

The initial setting will be OFF at this time.

With above steps finished, the boost controller can be used.



## Explanation of basic operation and MODE

### 1. Basic operation

Turn the encoder to select and change the values or units. Push (press) the encoder to confirm. Keep pressed the LEFT switch for over three seconds and the peak value will be cleared. Press the RIGHT switch and it will go back one operational step. The UP and DOWN switch can be used as a shortcut keys.

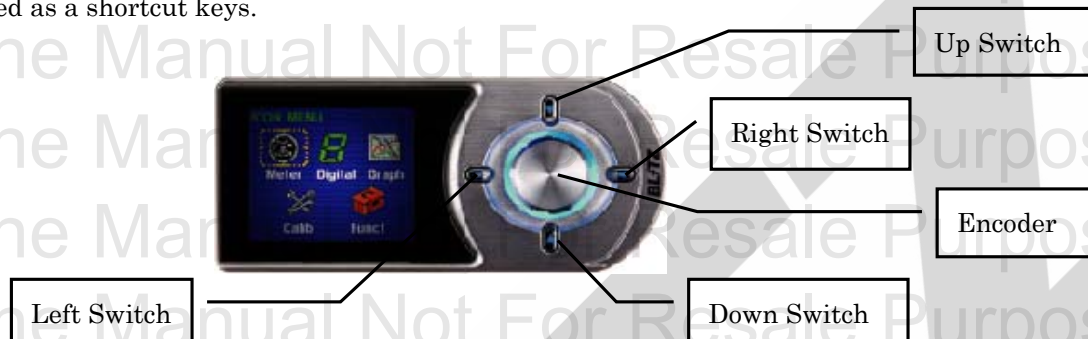

### 2. ICON MENU

Turn the encoder to select from the 5 ICONS (METER, DIGITAL, GRAPH, CALIBRATION, FUNCTION) and then push (press) the encoder to confirm the desired icon.

Press the LEFT switch for a short period and the LCD will shift from night to day illumination and vice versa.

Press the RIGHT switch and it will jump to the "Needle Meter" display.

Press the DOWN switch and it will jump to the "Six Fold" display.

**Boost control functions will not be displayed if used as MMD i-Color**

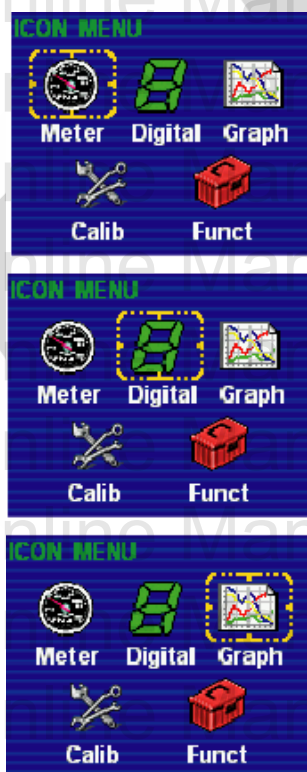

#### 1. Meter Icon

An analog meter with four different background colors and able to display 8 different sources of data such as:

- Boost
- Speed
- Tach
- Power
- Temp
- A/F
- Fuel pressure
- Oil pressure

#### 2. Digital Icon

A digital meter that can display two or six data simultaneously from 9 different data sources and can record and replay up to 10 minutes. (The record and replay function is only valid on digital display)

- Speed
- Tach
- Power
- Temp
- AUX (A/F, Press)
- BOOST
- DATA 1 (External Input)
- DATA 2 (External Input)
- DATA 3 (External Input)

#### 3. Graph Icon

It is able to function as a chassis dynamo which can graphically display the curve lines of horsepower and torque. Moreover, it also can graphically display the measured data such as the A/F, boost and power/torque. The horizontal axis is always the RPM.



4. Calib Icon  
A mode to input the initial adjustable values on six items. Functions will not work properly if it is not set up after initial power up of the SBC or MMD.

- SPEED
- TACHO
- POWER
- VOLTAGE
- BOOST SET UP
- BOOST MAP

**Boost control functions will not be displayed if used as MMD i-Color. (Only 4 items)**



5. Funct Icon  
A total of 24 detailed settings can be set here. For example, display direction, warning, unit change, font color, etc are customized.

3. Needle Meter

It simultaneously displays 4 different sources of data on an analog type meter screen. (The design of the meter's face can be chosen from white, black, carbon and blue)

It can also easily jump to the SBC setting by a shortcut.

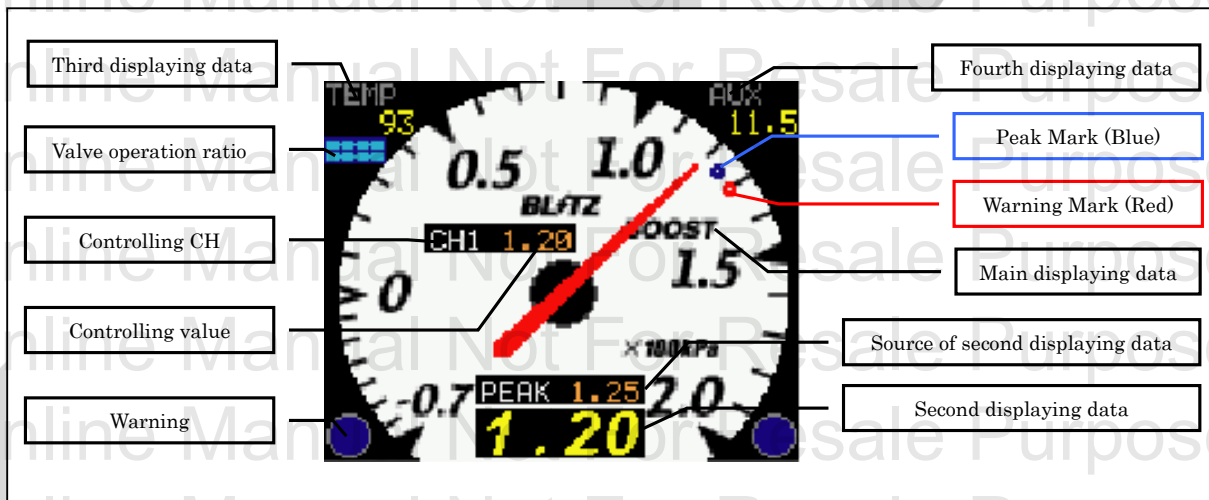

Press the LEFT switch to shift from night and day illumination and vice versa.

Press the LEFT switch for over 3 seconds and it will only clear the peak value of the displayed data.

Press UP to switch the screens from Meter screen → Boost Set up → Dual digital screen → Six fold digital screen → Result screen → Chassis dynamo screen → A/F graph screen → Boot graph screen → MAP screen → Speed MAP screen (The screen will shift to the other direction by keeping pressing the UP switch)  
(The boost setup, boost graph and MAP screen will not be displayed if it is not connected to the CPU unit)

Press the DOWN switch to change the meters from Boost pressure → Speed → RPM → Horse Power → Temp → A/F → Fuel Press → Oil Press.  
(The boost pressure will not be displayed if it is not connected to the CPU unit)



Press the RIGHT switch to go back to the ICON MENU.

Turn the ENCODER to change the design of the back ground from white → Black → Carbon → Blue.



Pressing the encoder button for over 2 seconds will shift to the boost control CH change mode.

Press the encoder again to confirm the change or press the RIGHT switch to cancel the operation.

The UP Switch is also a short cut key to return from the CH change mode and controlled value change mode and the changes will take effect.



By pressing the encoder once again, it will shift to the change mode of the boost set value.

The changes will take effect instantly in a case of MANU mode.

See the AUTO and MANU boost set up for detailed explanation.

The changes will only take effect after the encoder is pressed while at ATUO mode.

Press the RIGHT switch to go back to the previous screen or press the UP switch to confirm the changes and go back to the previous screen.



Will shift to the display items (second ~ fourth) change mode by pressing the encoder for a short while at the first screen. It will return to the previous screen if any operation is not performed for 10 seconds. The second item is the selection of the "METER PK" displayed value of the needle. Cannot be left blank in this case.

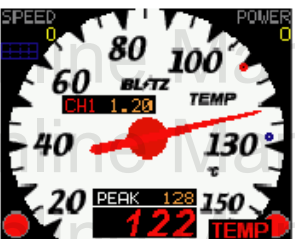

The needle will turn red and blink when the first item displayed at the needle meter becomes warning. The set warning will be displayed when the digital values of the second ~ fourth items becomes warning.

The source of the warning will pop out when a warning is set.

The controlled CH will be displayed in red when the boost pressure of the controlled CH is still in learning.



There is a slight difference in the location for the Peak Mark and the actual digital value of the Peak value. For example, the digital peak value is set at 0.80 hkPa but the Peak Mark would be located at 0.804 hkPa.



There is also a slight difference in the location of the Warning Mark and the set warning digital value because of the digitally processed dots.



#### 4. Digital Meter (Dual & Six Fold)

Displays in digital and bar graph the selected data sources. The types of display are Dual and Six Fold and the boost settings can be easily changed at the Dual display.

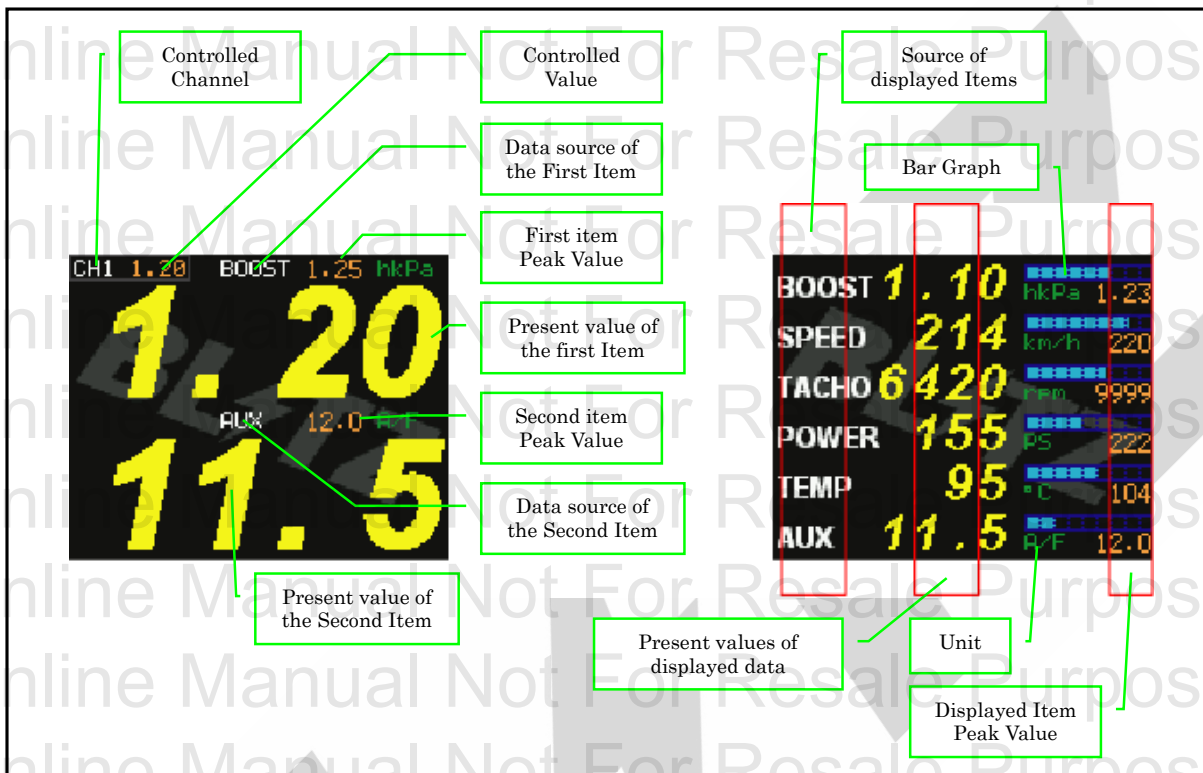

All the digital values are processed to keep displaying for 0.6 seconds and the bar graphs are processed to display in real time. The digital value will also change when the Peak value is changed. Moreover, the color at the digit will change when the warning value is reached. The Peak value will be displayed as a warning color for 3 seconds when the Peak value is updated.

#### Selection method of the screen

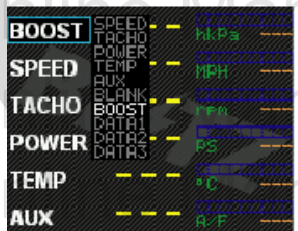

A selection border will pop up by pressing the encoder switch. Choose the item wanting to make changes by rotating the encoder and confirm by pressing it. Then it will shift to a selection screen with a list of items to choose from. The changes will be canceled and it will go back to the selection screen by pressing the RIGHT switch or it will return to the digital display screen without making any changes if no operation is performed for 10 seconds.

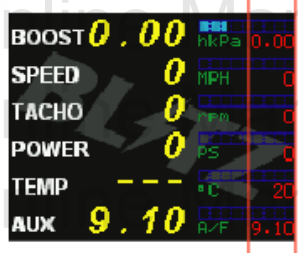

It will shift from day and night lighting by pressing the LEFT switch for a short moment. (This operation is the same on every screen) Press the LEFT switch for over 3 seconds and it will only clear the peak value of the displayed data. It will go back up one MENU by pressing the RIGHT switch.

Press UP to switch the screens from Meter screen → Boost Set up → Dual digital screen → Six fold digital screen → Result screen → Chassis dynamo screen → A/F graph screen → Boot graph screen → MAP screen → Speed MAP screen (The screen will shift to the other direction by keeping pressing the UP switch) (The boost setup, boost graph and MAP screen will not be displayed if it is not connected to the CPU unit)

Up dated Peak value

### Record and Replay Function



Press the DOWN switch for over 3 seconds to start recording.  
 Press the DOWN switch for over 3 seconds again to stop recording.  
**The Peak value will turn red if the peak value is updated while recording.**  
 Press the DOWN switch while recording to start re-playing.  
 Turn the encoder to rewind or fast-forward while re-playing.  
 Press the DOWN switch to stop re-playing.  
 The maximum recording time is 10 minutes and 9 seconds.

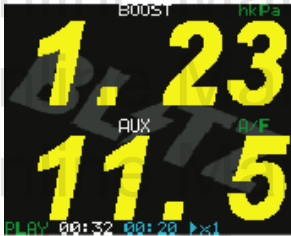

**The recorded data will be erased at IGN-OFF.**  
 The Peak value will not be displayed at re-play.  
 The boost controller and all other functions will work normally while re-play.

It can change screens while at recording or re-playing. In this case, it can display the data in real time on other screens even while re-playing.  
 The units for speed, horsepower and the settings of the voltage at AUX DATA 1~3 can be changed while recording or re-playing.  
 The displayed items can be changed since all the data source are recorded



The scales of the Six Fold bar graph are fixed as shown.

Speed:	0~260 km/h.
RPM:	0~10,000 rpm.
Horsepower:	0~350 ps.
Temperature:	20~150 °C.
Boost:	-0.8~2.00 hPa.
Voltage:	FIT Value.

### The following functions are only valid at the Dual Digital Meter



A warning indication will pop up at the bottom of the screen.

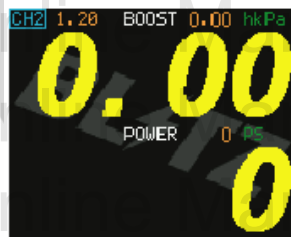

The CH change mode can be selected by keeping pressing on the encoder.  
 The changes will take effect after making the changes and pressing the encoder once again.



By pressing the encoder once again, it will shift to the change mode of the boost set value.  
 The changes will take effect instantly while at MANU mode.  
 The changes will only take effect after the encoder is pressed while at ATUO mode.  
 No changes can be done while recording or re-playing and vice versa.



## 5. Graphic Display.

It can be composed of 4 overlapped result graphs. The horizontal axis is the RPM.

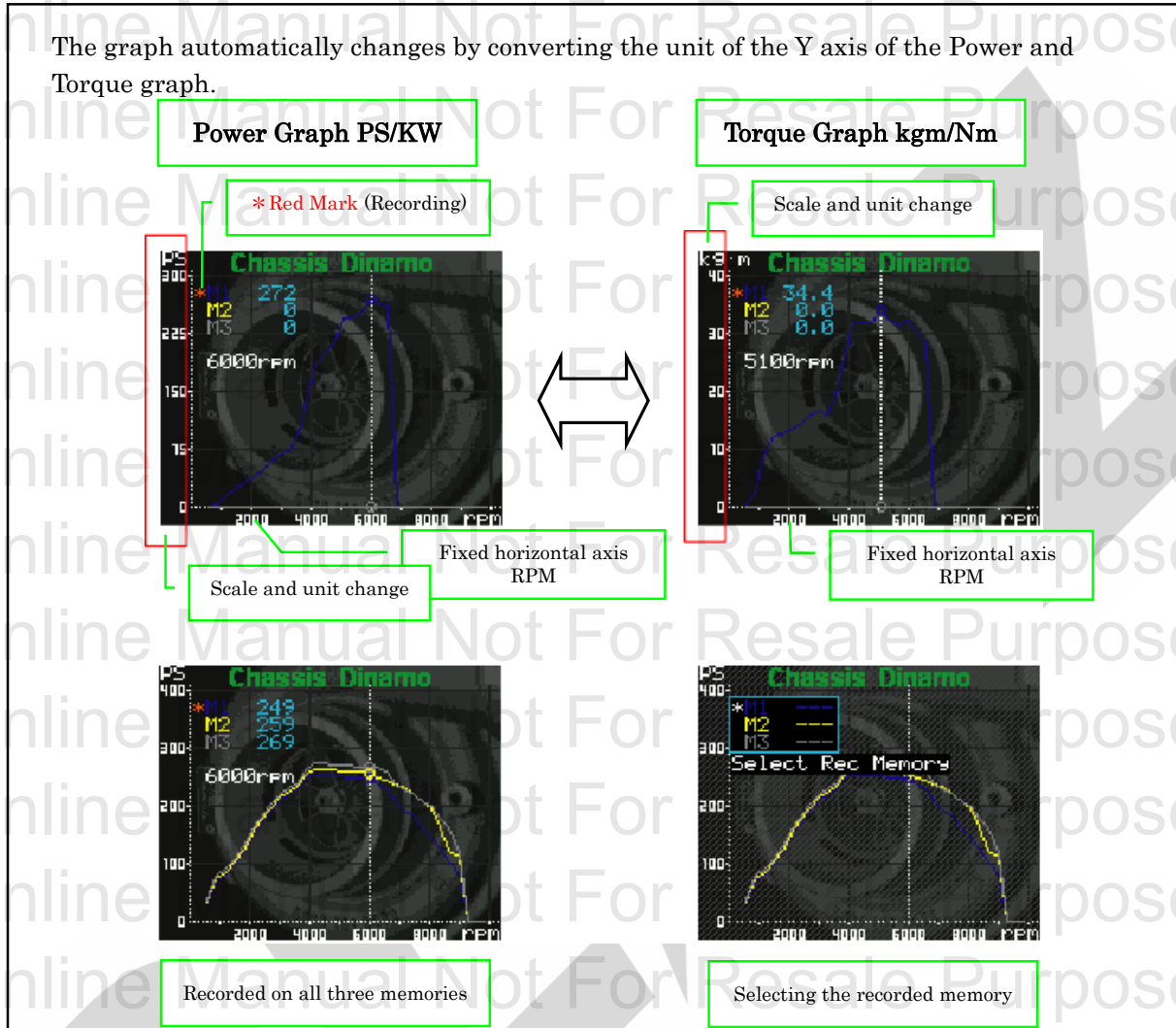

### ①. Chassis Dynamo Graph (Three channels of chassis dynamo are graphically displayed)

Turn the encoder and the cursor will move right and left to display the horsepower at the intersecting point of the graph line and RPM.

Press the encoder to highlight the recording channel; then, turn the encoder to select a channel number. Press the encoder to confirm the changes and it will shift to the unit setting. Choose the desired unit from 4 selections of units by turning the encoder. Press the encoder to confirm the changes and it will shift to the scale setting. Select the scale of the Y-axis by turning the encoder (The RPM at the X-axis is fixed). Press the encoder to confirm the changes and it will shift back to the chassis dynamo graph (Press RIGHT to cancel the changes and to return to the previous screen) Keep pressing the LEFT switch for 3 seconds to clear the memory with the \* or keep pressing for 3 more seconds to clear all the three memories. Press UP to switch the screens from Meter screen → Boost Set up → Dual digital screen → Six fold digital screen → Result screen → Chassis dynamo screen → A/F graph screen → Boost graph screen → MAP screen → Speed MAP screen (The screen will shift to the other direction by keeping pressing the UP switch)

(The boost setup, boost graph and MAP screen will not be displayed if it is not connected to the CPU unit)

#### Advice:

Press DOWN to show only the graph. This function will take effect for 6 seconds.

**A/F Air Fuel Ratio Graph**

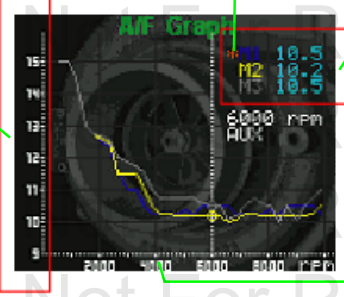

**\* Red Mark (Recording)**

**Recorded Memory**

**Fixed 9-15 scale**

**Fixed horizontal axis RPM**

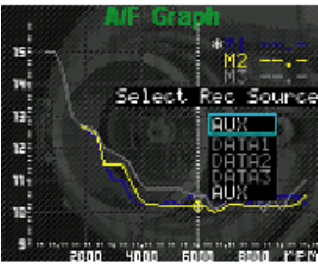

**Selection of recording source.**  
It can be freely combined with any of the 4 sources such as AUX~DATA 1-3.  
(All the sources can also be the same).

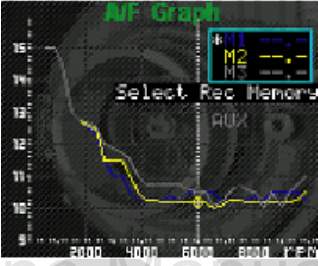

**Selection of recording memory.**  
It is possible to record each source on different memories. Ex: AUX on M1, DATA 1 at the external voltage on M2, etc.

If comparing data from the same sensor,  
M1: Boost at 1.0  
M2: Boost at 1.2  
M3: Boost at 1.5  
With this set up, each boost setting characteristic can be diagnosed and compared to each other.

## ②. A/F Graph (Air Fuel Ratio Graph)

It records and displays three memories of A/F graph based on RPM

Advice:

Make sure to setup the external voltage input of 16.0 V to read as 16.0.

An optional amp unit can also be attached to the AUX port.

Turn the encoder and the cursor will move right and left to display the A/F ratio at the intersecting point of the graph line and RPM. Press the encoder to highlight the recording channel; then, turn the encoder to select a channel number. Press the encoder to confirm the changes and it will shift back to the graph display screen (Press RIGHT to cancel the changes and to return to the previous screen)

All the other functions are the same as the Chassis Dynamo Graph.

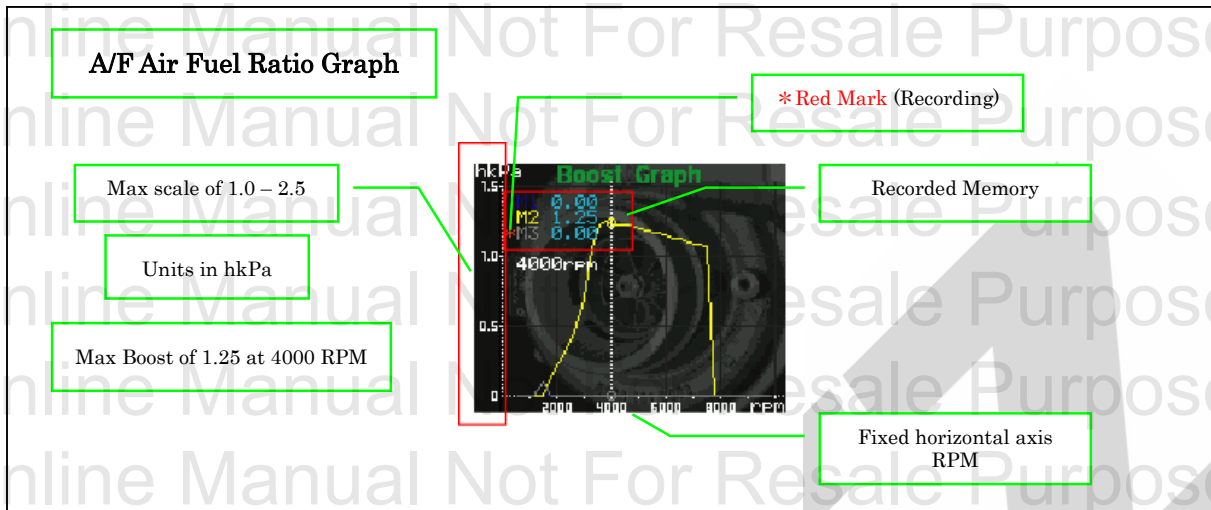

### ③. Boost Graph

It records and displays three memories of boost graph based on RPM. Turn the encoder and the cursor will move right and left to display the boost at the intersecting point of the graph line and RPM. Press the encoder to highlight the recording channel; then, turn the encoder to select a channel number. Press the encoder to confirm the changes and it will shift to the scale setting. Select the scale of the Y-axis by turning the. Press the encoder to confirm the changes and it will shift back to the boot graph (Press RIGHT to cancel the changes and to return to the previous screen). All the other functions are the same as the Chassis Dynamo Graph.

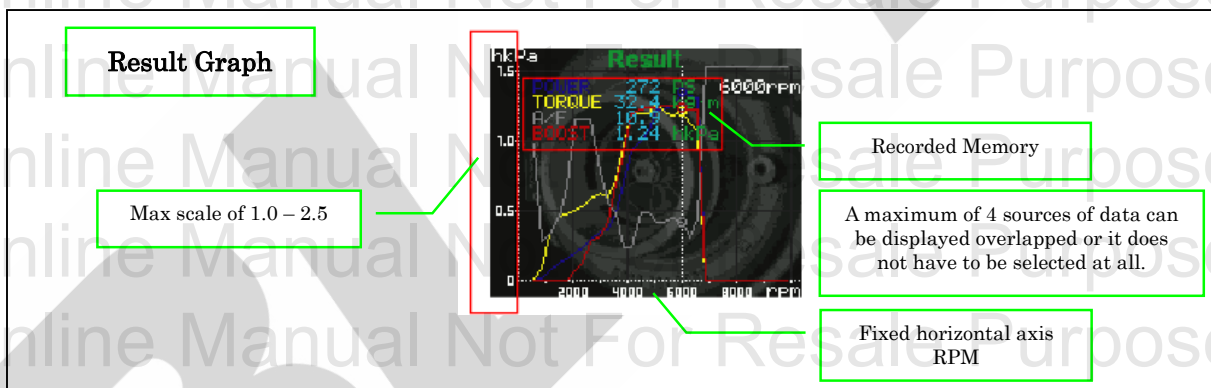

### ④. Result Graph

Displays simultaneously the chassis dynamo power, chassis dynamo torque, A/F and boost based on RPM. Turn the encoder and the cursor will move right or left to display the boost at the intersecting point of the graph line and RPM. Press the encoder to shift to the display setting change mode. Move the cursor to the desired item and then press the encoder to confirm. It will shift back to the previous screen if it is left without operation for 10 seconds.

The graph will not be displayed if the M1~3 is selected as “—”.

Press RIGHT to cancel the changes and to return to the previous screen.

All the other functions are the same as the Chassis Dynamo Graph.

6. Calibration Mode.

Initial setting and calibration in using the SBC or MMD

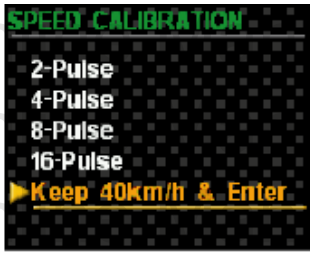

① Speed Calibration  
 A selection of 2P, 4P, 8P, 16P and 40km/h are available. (A maximum capability of 160P).  
 Calibration is not needed if the pulse of the vehicle is known. However, if the pulse is not known, the "Keep 40km/h & Enter" calibration must performed to acquire a reliable speed pulse.  
 Advice:  
 Keep performing the "Keep 40km/h & Enter" calibration until a reliable speed pulse is acquired.

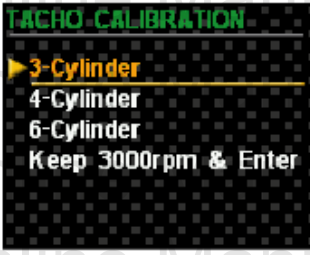

② RPM Calibration  
 A selection of 3, 4, 6 cylinders and 3000 RPM are available depending on the vehicle. Keep the engine RPM at 3000 and press the encoder to calibrate the RPM is the default settings cannot obtain a reliable RPM. (A maximum capability of 18 cylinders)

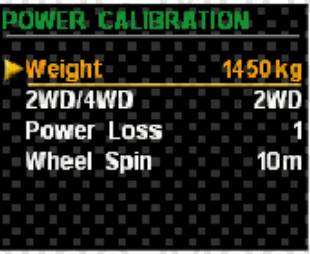

③ Horsepower Calibration  
 Input the following 4 items by turning the encoder.  
 Weight of the vehicle. 100~4500 kg.  
 Type of drive train. 2WD or 4WD  
 Road resistance. -15~+34. (See the attached list for reference)  
 Wheel spin distance. 0~50 meters  
 Advice:  
 Make sure to input a data as accurate as possible for a reliable calculation.

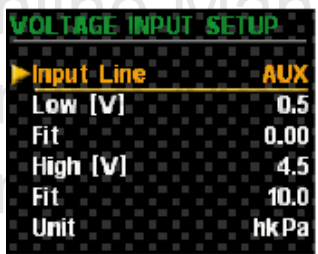

④ Setting of Voltage Data  
 It sets the displayed unit value and the inputted voltage value to be displayed as a two-point relation.  
 One AUX port and three external voltage inputs are available.  
 An optional harness is necessary for external voltage input.  
 Advice:  
 Code 19211 Press Sensor FIT value would be as follow.  
 Input Line AUX: Low=0.5V→FIT=0.00, High=4.5V→FIT=10.0  
 (FIT Value of = 10.0) X 100kPa = 1000kPa (Pressure value)  
 1.00psi = 6.89kPa.



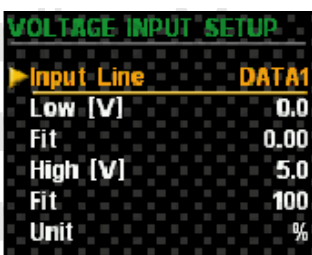

Explanation of Input Voltage Display

Input Line: AUX, DATA1~3  
 Low Voltage: 0.0~16.0V  
 High Voltage: 0.0~16.0V  
 Low FIT Value: -999~9999  
 High FIT Value: -999~9999



FIT Value Display Units:  
 0.00~9.99  
 10.0~99.9  
 100~999  
 -01~-99  
 -10~-999

Unit: A maximum of 5 digits.



⑤ Boost Setting

Settings on CH1~4, EXT, OFF, AUTO/MANU (SET 0.00~2.45/0 ~100) , GAIN 0 ~ 100.

CH1~4: Set the desired boost on each CH.  
 EXT: Interfacing function with an optional MAP analyzer.  
 OFF: It cancels the boost control function. As a result it operates only on the actuator's operation pressure.  
 MAP: Automatically changes the setting of the boost depending on the vehicle speed or RPM.  
 AUTO/MANU: Switch-over of Auto and Manu setting of boost control.  
 SET: AUTO 0.00~2.45 hkPa  
 MANU 0~100 Point type.  
 GAIN: Ratio 0~100  
 Configures the characteristics of boost lag.

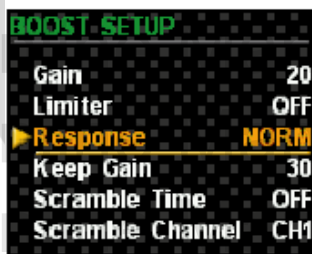

⑥ Selection of Learning Modes at AUTO Mode

There are times the self learning period at AUTO mode does not finish and keeps over shooting because of high response turbo or vehicles equipped with twin turbo. In this case, change the self learning method at the AUTO mode. Press DOWN for 5 seconds and a "RESPONSE" and "KEEP GAIN" will appear on the screen.

Response:  
 NORM: Default setting. It is the fastest for the boost to build up.  
 MILD: The starting point of boost is the same as NORM, but it is slightly slower to reach its peak.  
 SLOW: It is the slowest in the starting point of boost and reaching its peak; however, it the setting with least boost over shoots which leads to faster learning period.  
 KEEP GAIN: It keeps the duty of the solenoid even after the boost reached its



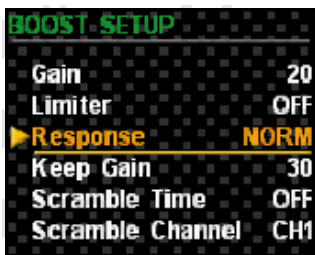

Advice:  
 It continues to adjust itself even after the self-learning mode (Red CH mark) disappears. The reason for this is because there are times the feedback value might greatly differ and to compensate it, it must continuously keep self-learning. Moreover, even if the set boost is 1.0 hkPa, the AUTO mode restrain the over shoot of the boost by stabilizing the boost at 0.98 hkPa. (This is not a malfunction)

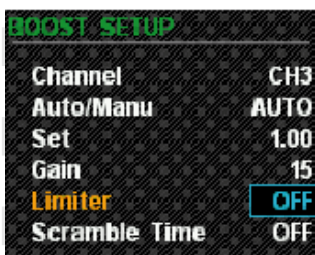

⑦ Limiter  
 If the boost pressure reaches the warning value, it will shift the boost to the limit pressure set at warning.

Configuration Method

Input the desired Point Value of 1~100. (The points are the same as the MANU Mode)  
 If the point value is not known, drive the car and verify the ratio between the point value and the hkPa. Another way is to change the Boost set up screen from AUTO to MANU and verify the point value at the MANU mode if the self-learning mode at a CH set on AUTO mode is finished.

※If the encoder is turned and pressed, the self-learning value will be cleared and shift to MANU control.



EX: Prevention of over shoot

Boost set at 1.0 hkPa at AUTO mode  
 Warning set at 1.05 hkPa, and limiter set at 1.0 hkPa.  
 The MANU point value is 34 when switched from AUTO Mode 1.0 hkPa.  
 Therefore, set the limiter point value at 34.

Co relationship of the Limiter and Warning

	Limiter ON	Limiter OFF
Warning	Boost Warning is Automatically Turned ON	Boost Warning is Automatically Turned OFF
	Warning ON	Warning OFF
Limiter	Set the Boost Limiter	Boost limiter Disabled

List of Warning Messages in English

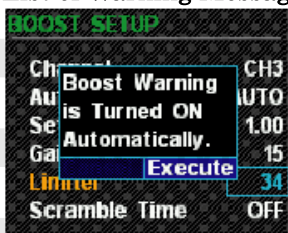

Limiter ON

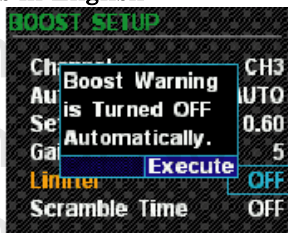

Limiter OFF

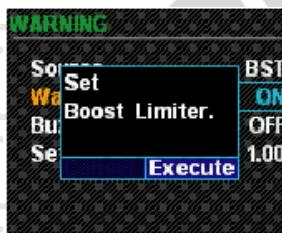

Warning ON

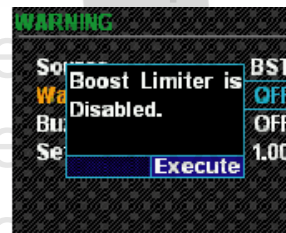

Warning OFF

List of Warning Messages in Japanese

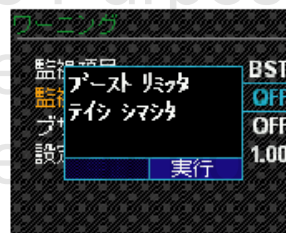
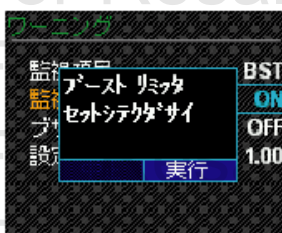
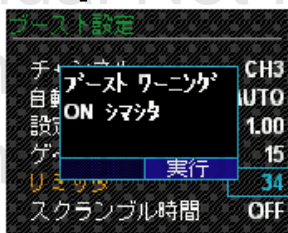
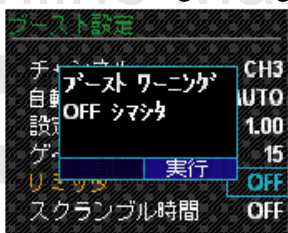

- ⑧ Scramble Time  
Time: OFF~99  
The scramble function will not work if the time is set as 0.  
The maximum is 99 seconds.  
The diagram on the left is when the scramble time is set at 5 seconds.



- ⑨ Scramble Channel  
In put the CH1~4 to be set as scramble.  
Make sure the self-learning mode is finished at the AUTO CH selected as the scramble channel.  
An "SC" mark will be displayed at the needle meter screen when the scramble mode is set for more than 1 second.

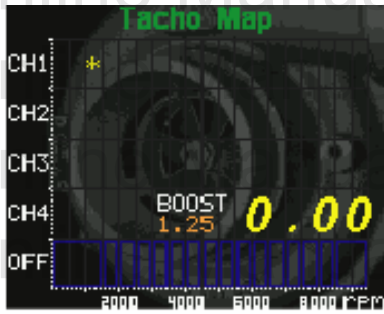

- ⑩ RPM MAP  
Controls the boost based on RPM.

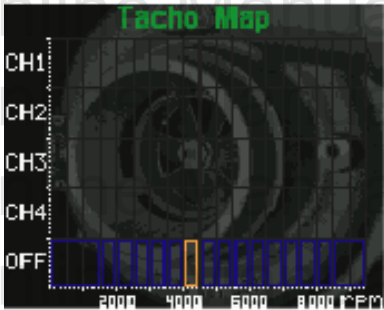

Configuration Method:

16 blue frames represent the MAP.  
The maximum RPM is 9000.

A yellow cursor represents the present tracing.

When the controlled CH is not the MAP, the “\*” mark will trace the controlled CH. The trace mark will not be displayed at the EXT control.

The boost and the peak value is displayed at the left bottom of the screen.

Press the LEFT switch for over 3 seconds and it will clear the boost peak value. The digital display specs are the same as the dual and six fold digital display.

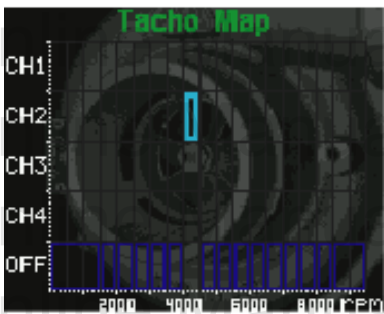

Press the encoder and the blue frame will change to orange to select the location and turn the encoder to select the RPM range where changes would take place. Press the encoder to confirm the changes and it will shift to the change screen. Select the CH1~OFF by turning the encoder. Press the encoder to confirm the changes and it will shift to the MAP display. (Press RIGHT to cancel the changes and to return to the previous screen)

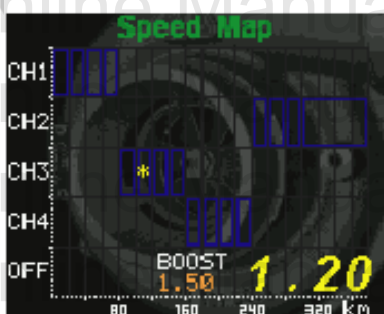

- ⑪ Speed MAP  
Controls the boost based on Speed.  
The operating methods are the same as the RPM MAP.



### 7. Function Mode.

Initial setting and calibration in using the SBC or MMD

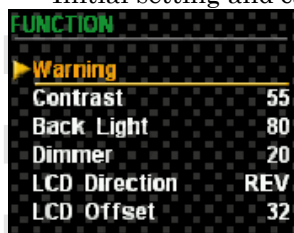

① Warning

Warning Supervision	To Do	Not To Do
Buzzer	Alert	Not Alert
Direction of Supervision	OVER	UNDER
Set Value	Depends on the input source	

Advice:

The direction of supervision of the boost is fixed to OVER.

A limiter selection window will pop up when the boost-warning switch is selected.

The limiter function will take effect when the boost-warning switch is turned ON.

### Example of Source Selection

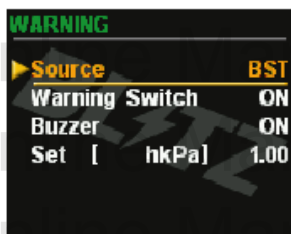

Source: Boost

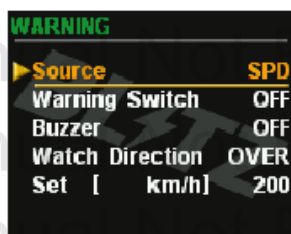

Source: Speed

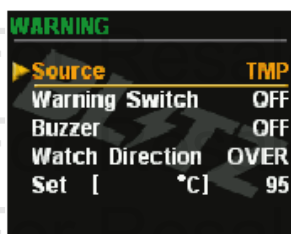

Source: Temp

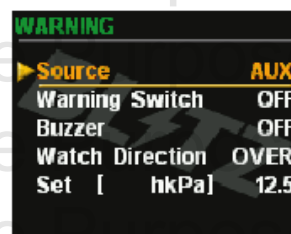

Source: AUX

### Example of Meter Warning

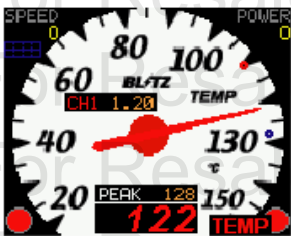

Advice:

The needle center will blink red when both the warning source screen and the meter screen are the same. However, it will alert by a source pop up and a buzzer when the warning source and the meter are not the same. At the same time, the blue circles at the bottom corners will turn red.

### Example of Digital Warning



Single Warning



Dual Warning

Advice:  
At the Dual Digital Meter, the warning source will pop up at the bottom of the screen.

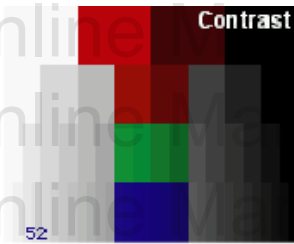

- ② Contrast  
Adjust from 0~100.  
Try to adjust so that the black and white can be clearly identified.  
Changes in contrast will not take effect below 25 and above 57.



- ③ Back Light  
Adjust the brightness from 0~100.



- Dimmer  
Adjust from 0~100.  
Commonly used by pressing the LEFT switch.



- ④ LCD Direction  
A multi angle function that can be chosen from Normal, Reverse and Vertical.

Advice:  
The Right, Left, Up and Down switches are automatically reconfigured by changing the LCD direction.

Multi Angle Function



- ⑤ LCD Offset  
It adjusts the offset of the LCD while viewed vertically.

Advice:  
The LCD display is basically made to be viewed horizontally. Therefore, the edges are cut off when viewed vertically. We suggest to set the offset at the position used the most.





⑥ Peak Mark  
A setting to display or not to display the blue peak  at the Needle Meter.

⑦ Warning Mark  
A setting to display or not to display the red warning  at the Needle Meter.

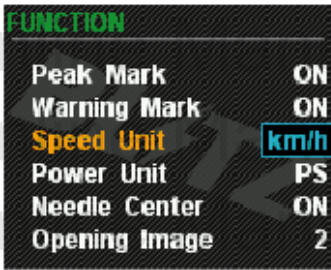

⑧ Speed Unit  
Choose from km/h or MPH.

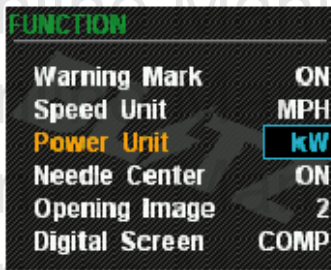

⑨ Power Unit  
Choose from PS or kw.

Advice:  
When the units are changed, the warning value, peak value and the meter units are automatically changed.  
However, it will not conjunct with the chassis dynamo screen units.

⑩ Needle Center  
It displays the center of the needle.

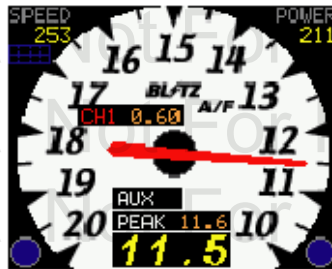
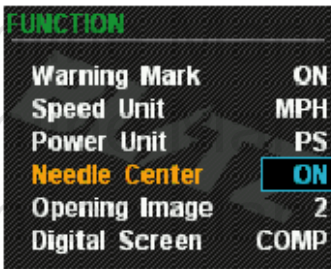

⑪ Opening Image  
Choose from the following tree choices.



- 12 Digital Screen  
Choose from the following three background designs.

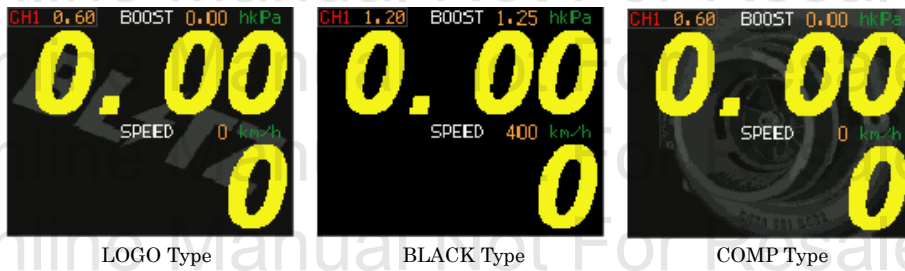

- 13 Graph Screen  
Choose from the following three background designs.

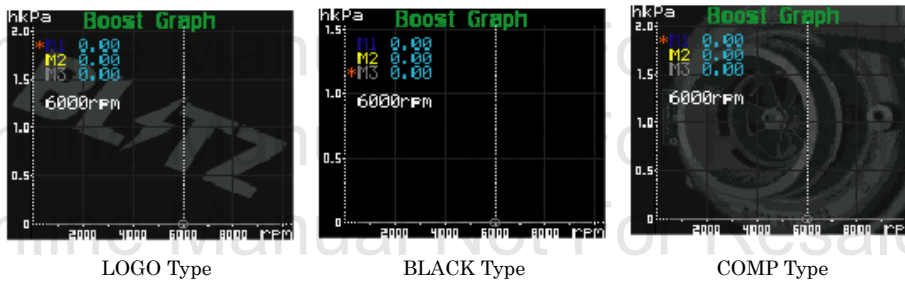

- 14 Menu Screen  
Choose from the following four background designs.

FUNCTION	PS	FUNCTION	PS	FUNCTION	PS	FUNCTION	PS
Power Unit	PS	Power Unit	PS	Power Unit	PS	Power Unit	PS
Needle Center	ON	Needle Center	OFF	Needle Center	OFF	Needle Center	ON
Opening Image	1	Opening Image	2	Opening Image	2	Opening Image	1
Digital Screen	LOGO	Digital Screen	BLACK	Digital Screen	BLACK	Digital Screen	LOGO
Graph Screen	COMP	Graph Screen	BLACK	Graph Screen	BLACK	Graph Screen	COMP
▶ Menu Screen	LOGO	▶ Menu Screen	CARB	▶ Menu Screen	BLACK	▶ Menu Screen	COMP

- 15 Font Color  
Choose the color of the Mid size fonts from 10 colors as shown at the screens below. (Ex: Orange Color)



Choose the color of the Large size fonts from 10 colors as shown at below dual digital meter. (Ex: Blue Color)

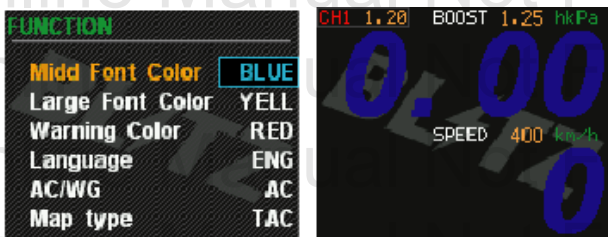

Dual Digital Meter

Warning Colors:

The color of the warning can also be set. (EX: Red Color)

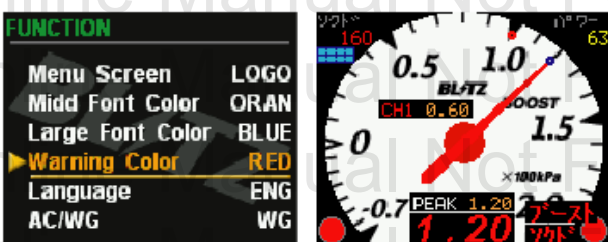

Warning set at 1.0 hkPa

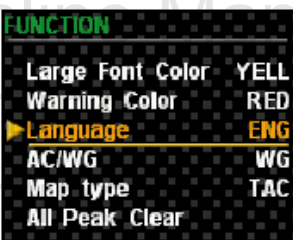

⑩ Language  
Choose a language. (English or Japanese)  
(Shown in English)

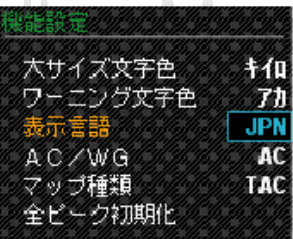

(Shown in Japanese)

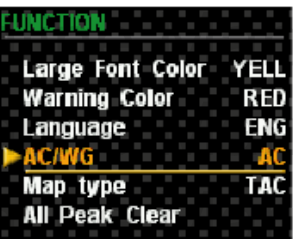

⑪ AC/WG  
Select the type of valve.

Advice:  
Make sure to select the correct type of valve since it might damage or break the vehicle.



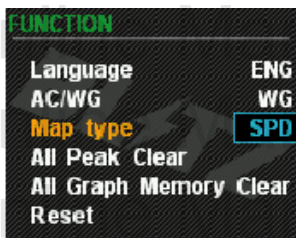

⑱ Map type  
It selects the source of data (Speed or PRM) to control the boost MAP.

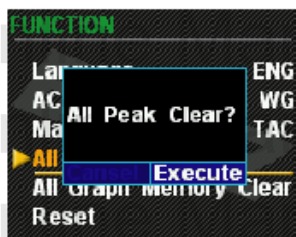

⑲ Reset  
All Peak Clear.

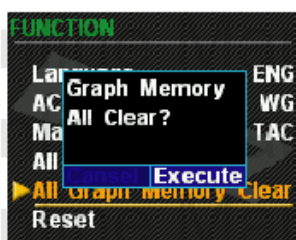

All Graph Memory Clear.

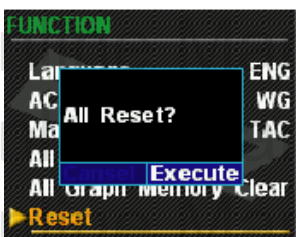

Reset  
It will reset all the values at the time of shipment.

**8. Demonstration Function.**

Turn the power ON while pressing UP. To cancel the demonstration function, turn the power ON while pressing DOWN.

For warranty, technical help or any other inquiries, please contact your local retail shop or Blitz Performance Sales, Inc.

Blitz Performance Sales, Inc.  
17300 Railroad St, Unit B  
City of Industry, CA 91748  
Phone: (626) 839-8350  
Fax: (626) 839-8340