























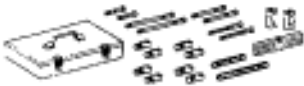

ENGINE

ENGINE MECHANICAL

PREPARATION







SST (SPECIAL SERVICE TOOLS)

	09201-10000	Valve Guide Bushing Remover & Replacer Set	
	(09201-01060)	Valve Guide Bushing Remover & Replacer 6	
	09202-70010	Valve Spring Compressor	
	09213-70010	Crankshaft Pulley Holding Tool	
	09222-30010	Connecting Rod Bushing Remover & Replacer	
	09223-15030	Oil Seal & Bearing Replacer	Crankshaft rear oil seal
	09248-55040	Valve Clearance Adjust Tool Set	
	(09248-05410)	Valve Lifter Press	
	(09248-05420)	Valve Lifter Stopper	
	09301-00110	Clutch Guide Tool	2JZ-GE M/T
	09316-60010	Transmission & Transfer Bearing Replacer	
	(09316-00010)	Replacer Pipe	Crankshaft front oil seal Camshaft oil seal

	(09316-00050) Replacer "D"	Camshaft oil seal
	09330-00021 Companion Flange Holding Tool	Crankshaft pulley
	09608-30022 Front Hub Bearing Replacer Set	
	(09608-05010) Handle	Crankshaft rear oil seal Valve guide bushing
	09816-30010 Oil Pressure Switch Socket	Knock sensor Oil pressure switch
	09843-18020 Diagnosis Check Wire	
	09950-50010 Puller C Set	
	(09951-05010) Hanger 150	Crankshaft pulley Crankshaft timing pulley
	(09952-05010) Slide Arm	Crankshaft pulley Crankshaft timing pulley
	(09953-05020) Center Bolt 150	Crankshaft pulley Crankshaft timing pulley
	(09954-05010) Claw No.1	Crankshaft timing pulley
	(09954-05030) Claw No.3	Camshaft pulley
	09960-10010 Variable Pin Wrench Set	
	(09962-01000) Variable Pin Wrench Arm Assy	Camshaft timing pulley

	(09963-01000) Pin 10	Camshaft timing pulley
---	----------------------	------------------------

RECOMMENDED TOOLS

	09040-00010 Hexagon Wrench Set •	
	09043-50100 Bi-hexagon Wrench 10 mm •	Cylinder head bolt
	09044-00020 Torx Socket E10 •	A/C compressor stud bolt
	09082-00050 TOYOTA Electrical Tester Set •	
	09090-04010 Engine Sling Device •	For suspending engine
	09200-00010 Engine Adjust Kit •	
	09258-00030 Hose Plug Set •	

EQUIPMENT

Caliper gauge	
CO/HC meter	
Compression gauge	
Connecting rod aligner	
Cylinder gauge	
Dial indicator	
Dye penetrant	
Engine tune-up tester	

Heater	
Micrometer	
Mirror	
Magnetic finger	
Piston ring compressor	
Piston ring expander	
Plastigage	
Precision straight edge	
Spring tester	Valve spring
Steel square	Valve spring
Thermometer	
Torque wrench	
Valve seat cutter	
Vernier calipers	
V-block	

SSM (SERVICE SPECIAL MATERIALS)

08826-00080	Seal Packing Black or equivalent (FIPG)	No.1 camshaft bearing cap Cylinder head Rear oil seal retainer
08833-00070	Adhesive 1324, THREE BOND 1324 or equivalent	Drive plate bolt (A/T) Union for oil cooler hose (2JZ-GTE)
08833-00080	Adhesive 1344, THREE BOND 1344, LOCTITE 242 or equivalent	Idler pulley pivot bolt Oil pressure switch

IDLE AND OR 2500 RPM CO HC CHECK

HINT: This check is used only to determine whether or not the idle CO/HC complies with regulations.

1. INITIAL CONDITIONS

- (a) Engine at normal operating temperature
- (b) Air cleaner installed
- (c) All pipes and hoses of air induction system connected
- (d) All accessories switched OFF
- (e) All vacuum lines properly connected

HINT: All vacuum hoses for EGR system, etc. should be properly connected.

- (f) SFI system wiring connectors fully plugged
- (g) Ignition timing set correctly
- (h) Transmission in neutral position
- (i) Tachometer and CO/HC meter calibrated by hand

2. START ENGINE

3. RACE ENGINE AT 2,500 RPM FOR APPROX. 180 SECONDS

4. INSERT CO/HC METER TESTING PROBE AT LEAST 40 cm (1.3 ft) INTO TAILPIPE DURING IDLING

5. IMMEDIATELY CHECK CO/HC CONCENTRATION AT IDLE AND/OR 2,500 RPM

HINT: When performing the 2 mode (2,500 rpm and idle) test, follow the measurement order prescribed by the applicable local regulations.

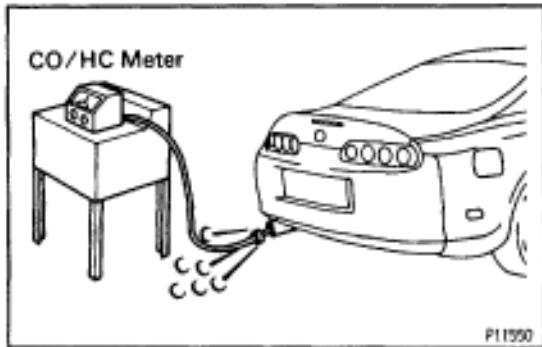

Troubleshooting

If the CO/HC concentration does not comply with regulations, troubleshoot in the order given below.

- (a) Check (main heated) oxygen sensors operation.
(See oxygen sensor(s) inspection in SFI System)
- (b) See the table below for possible causes, and then inspect and correct the applicable causes if necessary.

CO	HC	Phenomenon	Causes
Normal	High	Rough idle	<ol style="list-style-type: none"> 1. Faulty ignitions: <ul style="list-style-type: none"> • Incorrect timing • Fouled, shorted or improperly gapped plugs • Open or crossed high-tension cords (2JZ-GE) • Cracked distributor cap (2JZ-GE) 2. Incorrect valve clearance 3. Leaky EGR valve 4. Leaky intake and exhaust valves 5. Leaky cylinder
Low	High	Rough idle (Fluctuating HC reading)	<ol style="list-style-type: none"> 1. Vacuum leaks: <ul style="list-style-type: none"> • PCV hose • EGR valve • Intake manifold • Air intake chamber • Throttle body • IAC valve • Brake booster line 2. Lean mixture causing misfire
High	High	Rough idle (Black smoke from exhaust)	<ol style="list-style-type: none"> 1. Restricted air filter 2. Faulty SFI systems: <ul style="list-style-type: none"> • Faulty fuel pressure regulator • Clogged fuel return line • Defective ECT switch • Defective turbo pressure sensor (2JZ-GTE) • Faulty ECM • Faulty injector • Faulty throttle position sensor • Faulty VAF meter (2JZ-GE) • Faulty MAF meter (2JZ-GTE)

COMPRESSION CHECK

HINT: If there is lack of power, excessive oil consumption or poor fuel economy, measure the compression pressure.

1. WARM UP AND STOP ENGINE

Allow the engine to warm up to normal operating temperature.

2. 2JZ-GE:

DISCONNECT DISTRIBUTOR CONNECTOR

3. 2JZ-GTE:

DISCONNECT CAMSHAFT POSITION SENSOR CONNECTORS

4. 2JZ-GE:

DISCONNECT HIGH-TENSION CORDS FROM SPARK PLUGS

(See high-tension cords and cord clamps removal in Ignition System)

5. 2JZ-GTE:

REMOVE IGNITION COILS ASSEMBLIES

(See ignition coils removal in Ignition System)

6. REMOVE SPARK PLUGS

7. CHECK CYLINDER COMPRESSION

(a) Insert a compression tester into the spark plug hole.

(b) While cranking the engine, measure the compression pressure.

HINT: Always use a fully charged battery to obtain engine revolutions of 250 rpm or more.

(c) Repeat steps (a) through (b) for each cylinder.

NOTICE: This measurement must be done in as short a time as possible.

Standard pressure:

2JZ-GE

1,275 kPa (13.0 kgf/cm², 185 psi) or more

2JZ-GTE

1,079 kPa (11.0 kgf/cm², 156 psi) or more

Minimum pressure:

2JZ-GE

1,079 kPa (11.0 kgf/cm², 156 psi)

2JZ-GTE

883 kPa (9.0 kgf/cm², 128 psi)

Difference between each cylinder:

98 kPa (1.0 kgf/cm², 14 psi) or less

(d) If the cylinder compression in 1 or more cylinders is low, pour a small amount of engine oil into the cylinder through the spark plug hole and repeat steps (a) through (b) for the cylinder with low compression.

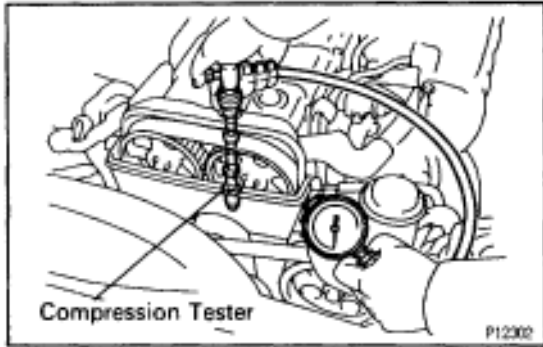

- If adding oil helps the compression, it is likely that the piston rings and/or cylinder bore are probably worn or damaged.
- If pressure stays low, a valve may be sticking or seating improper, or there may be leakage past the gasket.

8. REINSTALL SPARK PLUGS

9. 2JZ-GE:

RECONNECT HIGH-TENSION CORDS TO SPARK PLUGS

(See high-tension cords and cord clamps installation in Ignition System)

10. 2JZ-GTE:

REINSTALL IGNITION COILS ASSEMBLIES

(See ignition coils installation in Ignition System)

11. 2JZ-GE:

RECONNECT DISTRIBUTOR CONNECTOR

12. 2JZ-GTE:

RECONNECT CAMSHAFT POSITION SENSOR CONNECTORS

VALVE CLEARANCE INSPECTION AND ADJUSTMENT (2JZ-GE)

HINT: Inspect and adjust the valve clearance when the engine is cold.

1. REMOVE THROTTLE BODY AND INTAKE AIR CONNECTOR ASSEMBLY (See steps 1 to 9 in injector removal in SFI System)

2. DISCONNECT HIGH-TENSION CORDS FROM CYLINDER HEAD COVERS (See high-tension cords and cord clamps removal in Ignition System)

3. REMOVE NO.3, NO.1 AND NO.2 CYLINDER HEAD COVERS

- Remove the 4 bolts, 4 nuts and No.3 cylinder head cover.
- Remove the 4 bolts, No.1 cylinder head cover and gasket.
- Remove the 4 bolts, No.2 cylinder head cover and gasket.

4. SET NO.1 CYLINDER TO TDC/COMPRESSION

- Turn the crankshaft pulley, and align its groove with timing mark "O" of the No.1 timing belt cover.

NOTICE: Always turn the crankshaft clockwise.

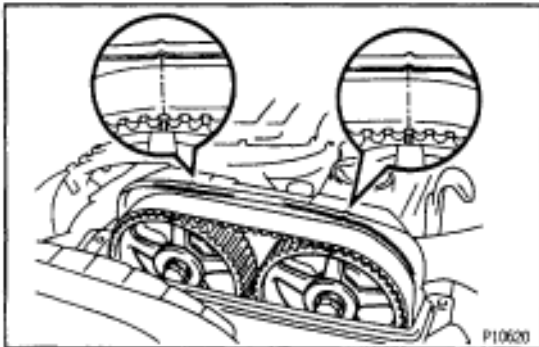
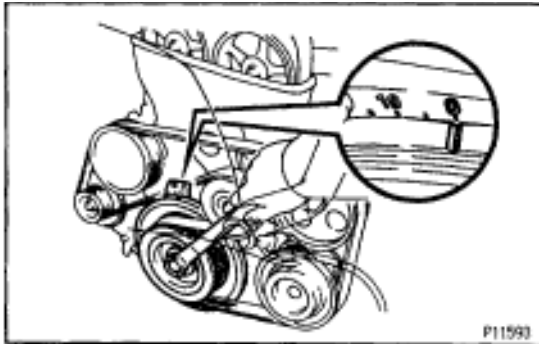
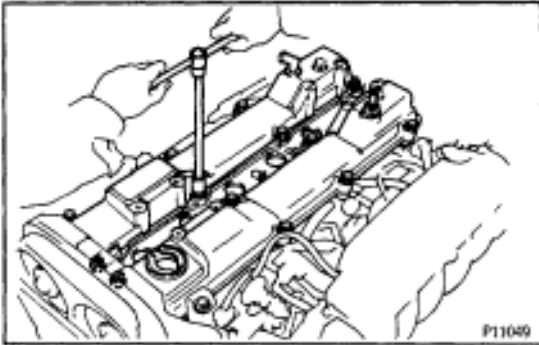

- Check that the timing marks of the camshaft timing pulleys are aligned with the timing marks of the No.4 timing belt cover.

If not, turn the crankshaft 1 revolution (360°).

5. INSPECT VALVE CLEARANCE

- Check only those valves indicated in the illustration.

- Using a feeler gauge, measure the clearance between the valve lifter and camshaft.
- Record the valve clearance measurements of those that are out of specification. They will be used later to determine the required replacement adjusting shim.

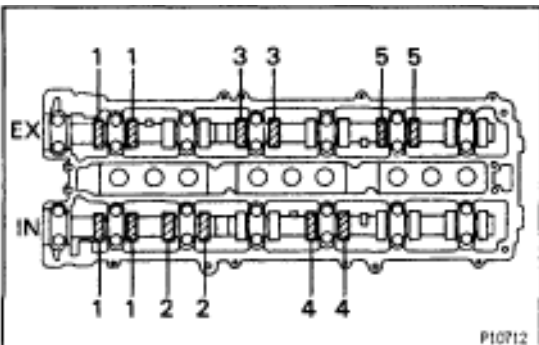

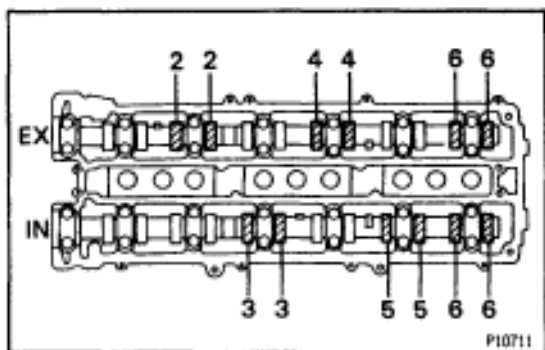
Valve clearance (Cold):**Intake****.15–0.25 mm (0.006–0.010 in.)****Exhaust****.25–0.35 mm (0.010–0.014 in.)**

- (b) Turn the crankshaft pulley 1 revolution (360°), and align the groove with timing mark "O" of the No.1 timing belt cover.
- (c) Check only the valves indicated as shown. Measure the valve clearance. (See procedure in step (a))

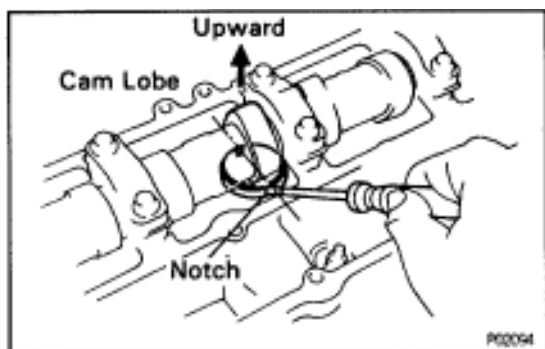
**6. ADJUST VALVE CLEARANCE**

- (a) Remove the adjusting shim.
- Turn the camshaft so that the cam lobe for the valve to be adjusted faces up.
 - Turn the valve lifter with a screwdriver so that the notches are perpendicular to the camshaft.

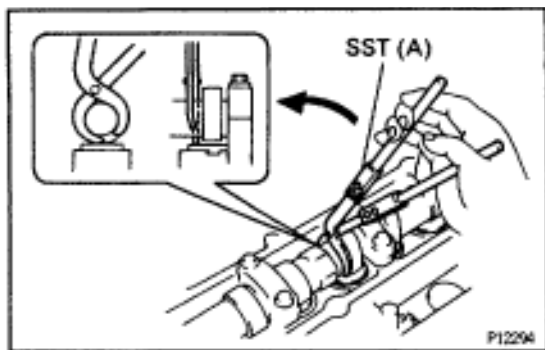

- Using SST (A), hold the camshaft as shown in the illustration.
SST 09248-55040 (09248-05410)

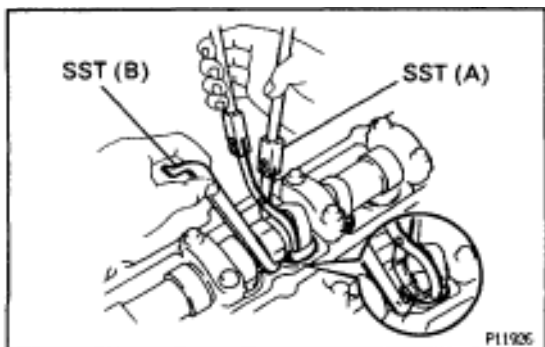

- Using SST (A), press down the valve lifter and place SST (B) between the camshaft and valve lifter. Remove SST (A).

SST 09248-55040 (09248-05410, 09248-05420)

HINT:

- Apply SST (B) at slight angle on the side marked with "7", at the position shown in the illustration.

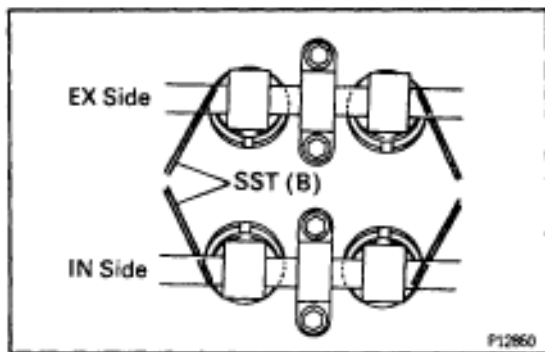

- Insert SST (B) gently from the inside as shown in the illustration.

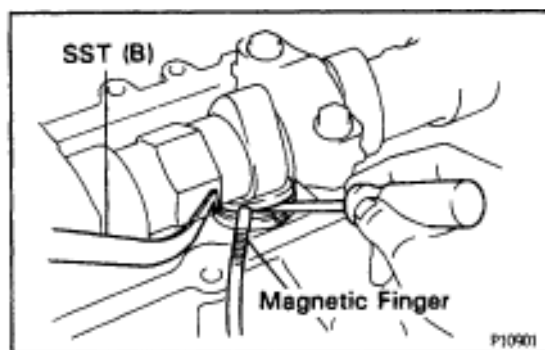

- Using a small screwdriver and a magnetic finger, remove the adjusting shim.

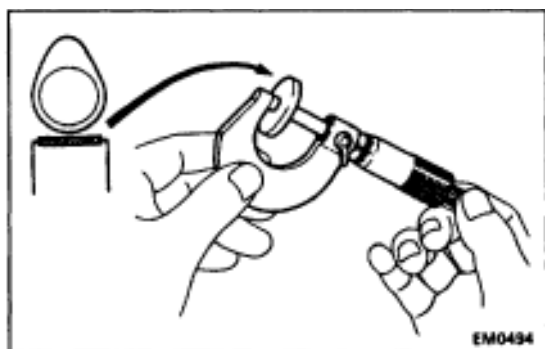

- (b) Determine the replacement adjusting shim size according to the following Formula or Charts on the next 2 pages:

- Using a micrometer, measure the thickness of the removed shim.
- Calculate the thickness of a new shim so the valve clearance comes within specified value.

T Thickness of used shim

A Measured valve clearance

N Thickness of new shim

Intake

$$N = T + (A - 0.20 \text{ mm (0.008 in.)})$$

Exhaust

$$N = T + (A - 0.30 \text{ mm (0.012 in.)})$$

- Select a new shim with a thickness as close as possible to the calculated values.

HINT: Shims are available in 17 sizes in increments of 0.050 mm (0.0020 in.), from 2.500 mm (0.0984 in.) to 3.300 mm (0.1299 in.).

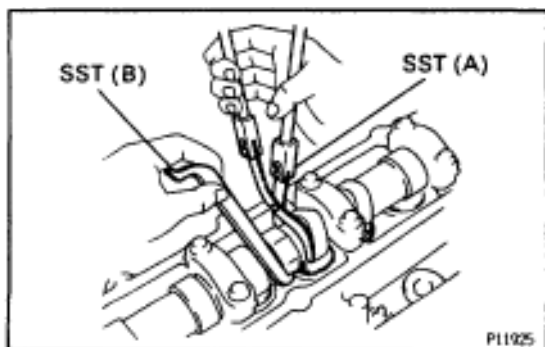

- (c) Install a new adjusting shim.

- Place a new adjusting shim on the valve lifter, with imprinted numbers facing down.
- Press down the valve lifter with SST (A), and remove SST (B).

SST 09248-55040

- (d) Recheck the valve clearance.

Adjusting Shim Selection Chart (Intake)

Measured clearance mm (in.)	Installed shim thickness mm (in.)	Shim No.	Thickness mm (in.)	Shim No.	Thickness mm (in.)
0.000 - 0.020 (0.0000 - 0.0008)	1	1	1.1	1	1.1
0.021 - 0.040 (0.0008 - 0.0016)	1	1	1.1	1	1.1
0.041 - 0.060 (0.0016 - 0.0024)	1	1	1.1	1	1.1
0.061 - 0.080 (0.0024 - 0.0032)	1	1	1.1	1	1.1
0.081 - 0.100 (0.0032 - 0.0040)	1	1	1.1	1	1.1
0.101 - 0.120 (0.0040 - 0.0048)	1	1	1.1	1	1.1
0.121 - 0.140 (0.0048 - 0.0056)	1	1	1.1	1	1.1
0.141 - 0.160 (0.0056 - 0.0064)	1	1	1.1	1	1.1
0.161 - 0.180 (0.0064 - 0.0072)	1	1	1.1	1	1.1
0.181 - 0.200 (0.0072 - 0.0080)	1	1	1.1	1	1.1
0.201 - 0.220 (0.0080 - 0.0088)	1	1	1.1	1	1.1
0.221 - 0.240 (0.0088 - 0.0096)	1	1	1.1	1	1.1
0.241 - 0.260 (0.0096 - 0.0104)	1	1	1.1	1	1.1
0.261 - 0.280 (0.0104 - 0.0112)	1	1	1.1	1	1.1
0.281 - 0.300 (0.0112 - 0.0120)	1	1	1.1	1	1.1
0.301 - 0.320 (0.0120 - 0.0128)	1	1	1.1	1	1.1
0.321 - 0.340 (0.0128 - 0.0136)	1	1	1.1	1	1.1
0.341 - 0.360 (0.0136 - 0.0144)	1	1	1.1	1	1.1
0.361 - 0.380 (0.0144 - 0.0152)	1	1	1.1	1	1.1
0.381 - 0.400 (0.0152 - 0.0160)	1	1	1.1	1	1.1
0.401 - 0.420 (0.0160 - 0.0168)	1	1	1.1	1	1.1
0.421 - 0.440 (0.0168 - 0.0176)	1	1	1.1	1	1.1
0.441 - 0.460 (0.0176 - 0.0184)	1	1	1.1	1	1.1
0.461 - 0.480 (0.0184 - 0.0192)	1	1	1.1	1	1.1
0.481 - 0.500 (0.0192 - 0.0200)	1	1	1.1	1	1.1
0.501 - 0.520 (0.0200 - 0.0208)	1	1	1.1	1	1.1
0.521 - 0.540 (0.0208 - 0.0216)	1	1	1.1	1	1.1
0.541 - 0.560 (0.0216 - 0.0224)	1	1	1.1	1	1.1
0.561 - 0.580 (0.0224 - 0.0232)	1	1	1.1	1	1.1
0.581 - 0.600 (0.0232 - 0.0240)	1	1	1.1	1	1.1
0.601 - 0.620 (0.0240 - 0.0248)	1	1	1.1	1	1.1
0.621 - 0.640 (0.0248 - 0.0256)	1	1	1.1	1	1.1
0.641 - 0.660 (0.0256 - 0.0264)	1	1	1.1	1	1.1
0.661 - 0.680 (0.0264 - 0.0272)	1	1	1.1	1	1.1
0.681 - 0.700 (0.0272 - 0.0280)	1	1	1.1	1	1.1
0.701 - 0.720 (0.0280 - 0.0288)	1	1	1.1	1	1.1
0.721 - 0.740 (0.0288 - 0.0296)	1	1	1.1	1	1.1
0.741 - 0.760 (0.0296 - 0.0304)	1	1	1.1	1	1.1
0.761 - 0.780 (0.0304 - 0.0312)	1	1	1.1	1	1.1
0.781 - 0.800 (0.0312 - 0.0320)	1	1	1.1	1	1.1
0.801 - 0.820 (0.0320 - 0.0328)	1	1	1.1	1	1.1
0.821 - 0.840 (0.0328 - 0.0336)	1	1	1.1	1	1.1
0.841 - 0.860 (0.0336 - 0.0344)	1	1	1.1	1	1.1
0.861 - 0.880 (0.0344 - 0.0352)	1	1	1.1	1	1.1
0.881 - 0.900 (0.0352 - 0.0360)	1	1	1.1	1	1.1
0.901 - 0.920 (0.0360 - 0.0368)	1	1	1.1	1	1.1
0.921 - 0.940 (0.0368 - 0.0376)	1	1	1.1	1	1.1
0.941 - 0.960 (0.0376 - 0.0384)	1	1	1.1	1	1.1
0.961 - 0.980 (0.0384 - 0.0392)	1	1	1.1	1	1.1
0.981 - 1.000 (0.0392 - 0.0400)	1	1	1.1	1	1.1
1.021 - 1.040 (0.0400 - 0.0408)	1	1	1.1	1	1.1
1.041 - 1.060 (0.0408 - 0.0416)	1	1	1.1	1	1.1

Shim No.	Thickness	Shim No.	Thickness
1	2.500 (0.0984)	10	2.950 (0.1161)
2	2.550 (0.1004)	11	3.000 (0.1181)
3	2.600 (0.1024)	12	3.050 (0.1201)
4	2.650 (0.1043)	13	3.100 (0.1220)
5	2.700 (0.1063)	14	3.150 (0.1240)
6	2.750 (0.1083)	15	3.200 (0.1260)
7	2.800 (0.1102)	16	3.250 (0.1280)
8	2.850 (0.1122)	17	3.300 (0.1299)
9	2.900 (0.1142)		

Intake valve clearance (Cold):
0.15 - 0.25 mm (0.006 - 0.010 in.)

EXAMPLE: The 2.800 mm (0.1102 in.) shim is installed, and the measured clearance is 0.450 mm (0.0177 in.). Replace the 2.800 mm (0.1102 in.) shim with a new No.12 shim.

HINT: New shims have the thickness in millimeters imprinted on the face.

Adjusting Shim Selection Chart (Exhaust)

Insulated shim thickness mm (in.)	Measured clearance mm (in.)	Shim No.	Thickness mm (in.)
0.000 - 0.020 (0.0000 - 0.0008)	0.000 (0.0000)	1	2.500 (0.0984)
0.021 - 0.040 (0.0008 - 0.0016)	0.021 (0.0008)	2	2.550 (0.1004)
0.041 - 0.060 (0.0016 - 0.0024)	0.041 (0.0016)	3	2.600 (0.1024)
0.061 - 0.080 (0.0024 - 0.0031)	0.061 (0.0032)	4	2.650 (0.1043)
0.081 - 0.100 (0.0032 - 0.0039)	0.081 (0.0039)	5	2.700 (0.1063)
0.101 - 0.120 (0.0039 - 0.0047)	0.101 (0.0047)	6	2.750 (0.1083)
0.121 - 0.140 (0.0048 - 0.0056)	0.121 (0.0056)	7	2.800 (0.1102)
0.141 - 0.160 (0.0056 - 0.0063)	0.141 (0.0063)	8	2.850 (0.1122)
0.161 - 0.180 (0.0063 - 0.0071)	0.161 (0.0071)	9	2.900 (0.1142)
0.181 - 0.200 (0.0071 - 0.0079)	0.181 (0.0079)	10	2.950 (0.1161)
0.201 - 0.220 (0.0079 - 0.0087)	0.201 (0.0087)	11	3.000 (0.1181)
0.221 - 0.240 (0.0087 - 0.0094)	0.221 (0.0094)	12	3.050 (0.1201)
0.241 - 0.260 (0.0094 - 0.0102)	0.241 (0.0102)	13	3.100 (0.1220)
0.261 - 0.280 (0.0102 - 0.0110)	0.261 (0.0110)	14	3.150 (0.1240)
0.281 - 0.300 (0.0110 - 0.0117)	0.281 (0.0117)	15	3.200 (0.1260)
0.301 - 0.320 (0.0117 - 0.0125)	0.301 (0.0125)	16	3.250 (0.1280)
0.321 - 0.340 (0.0125 - 0.0133)	0.321 (0.0133)	17	3.300 (0.1299)
0.341 - 0.360 (0.0133 - 0.0141)	0.341 (0.0141)	18	
0.361 - 0.380 (0.0141 - 0.0148)	0.361 (0.0148)	19	
0.381 - 0.400 (0.0148 - 0.0156)	0.381 (0.0156)	20	
0.401 - 0.420 (0.0156 - 0.0164)	0.401 (0.0164)	21	
0.421 - 0.440 (0.0164 - 0.0172)	0.421 (0.0172)	22	
0.441 - 0.460 (0.0172 - 0.0180)	0.441 (0.0180)	23	
0.461 - 0.480 (0.0180 - 0.0188)	0.461 (0.0188)	24	
0.481 - 0.500 (0.0188 - 0.0196)	0.481 (0.0196)	25	
0.501 - 0.520 (0.0196 - 0.0204)	0.501 (0.0204)	26	
0.521 - 0.540 (0.0204 - 0.0212)	0.521 (0.0212)	27	
0.541 - 0.560 (0.0212 - 0.0220)	0.541 (0.0220)	28	
0.561 - 0.580 (0.0220 - 0.0228)	0.561 (0.0228)	29	
0.581 - 0.600 (0.0228 - 0.0236)	0.581 (0.0236)	30	
0.601 - 0.620 (0.0236 - 0.0244)	0.601 (0.0244)	31	
0.621 - 0.640 (0.0244 - 0.0252)	0.621 (0.0252)	32	
0.641 - 0.660 (0.0252 - 0.0260)	0.641 (0.0260)	33	
0.661 - 0.680 (0.0260 - 0.0268)	0.661 (0.0268)	34	
0.681 - 0.700 (0.0268 - 0.0276)	0.681 (0.0276)	35	
0.701 - 0.720 (0.0276 - 0.0283)	0.701 (0.0283)	36	
0.721 - 0.740 (0.0283 - 0.0291)	0.721 (0.0291)	37	
0.741 - 0.760 (0.0291 - 0.0299)	0.741 (0.0299)	38	
0.761 - 0.780 (0.0299 - 0.0307)	0.761 (0.0307)	39	
0.781 - 0.800 (0.0307 - 0.0315)	0.781 (0.0315)	40	
0.801 - 0.820 (0.0315 - 0.0323)	0.801 (0.0323)	41	
0.821 - 0.840 (0.0323 - 0.0331)	0.821 (0.0331)	42	
0.841 - 0.860 (0.0331 - 0.0339)	0.841 (0.0339)	43	
0.861 - 0.880 (0.0339 - 0.0347)	0.861 (0.0347)	44	
0.881 - 0.900 (0.0347 - 0.0355)	0.881 (0.0355)	45	
0.901 - 0.920 (0.0355 - 0.0363)	0.901 (0.0363)	46	
0.921 - 0.940 (0.0363 - 0.0371)	0.921 (0.0371)	47	
0.941 - 0.960 (0.0371 - 0.0379)	0.941 (0.0379)	48	
0.961 - 0.980 (0.0379 - 0.0387)	0.961 (0.0387)	49	
0.981 - 1.000 (0.0387 - 0.0395)	0.981 (0.0395)	50	
1.001 - 1.020 (0.0395 - 0.0403)	1.001 (0.0403)	51	
1.021 - 1.040 (0.0403 - 0.0411)	1.021 (0.0411)	52	
1.041 - 1.060 (0.0411 - 0.0419)	1.041 (0.0419)	53	
1.061 - 1.080 (0.0419 - 0.0427)	1.061 (0.0427)	54	
1.081 - 1.100 (0.0427 - 0.0435)	1.081 (0.0435)	55	
1.101 - 1.120 (0.0435 - 0.0443)	1.101 (0.0443)	56	
1.121 - 1.140 (0.0443 - 0.0451)	1.121 (0.0451)	57	
1.141 - 1.160 (0.0451 - 0.0459)	1.141 (0.0459)	58	
1.161 - 1.180 (0.0459 - 0.0467)	1.161 (0.0467)	59	
1.181 - 1.200 (0.0467 - 0.0475)	1.181 (0.0475)	60	
1.201 - 1.220 (0.0475 - 0.0483)	1.201 (0.0483)	61	
1.221 - 1.240 (0.0483 - 0.0491)	1.221 (0.0491)	62	
1.241 - 1.260 (0.0491 - 0.0499)	1.241 (0.0499)	63	
1.261 - 1.280 (0.0499 - 0.0507)	1.261 (0.0507)	64	
1.281 - 1.300 (0.0507 - 0.0515)	1.281 (0.0515)	65	
1.301 - 1.320 (0.0515 - 0.0523)	1.301 (0.0523)	66	
1.321 - 1.340 (0.0523 - 0.0531)	1.321 (0.0531)	67	
1.341 - 1.360 (0.0531 - 0.0539)	1.341 (0.0539)	68	
1.361 - 1.380 (0.0539 - 0.0547)	1.361 (0.0547)	69	
1.381 - 1.400 (0.0547 - 0.0555)	1.381 (0.0555)	70	
1.401 - 1.420 (0.0555 - 0.0563)	1.401 (0.0563)	71	
1.421 - 1.440 (0.0563 - 0.0571)	1.421 (0.0571)	72	
1.441 - 1.460 (0.0571 - 0.0579)	1.441 (0.0579)	73	
1.461 - 1.480 (0.0579 - 0.0587)	1.461 (0.0587)	74	
1.481 - 1.500 (0.0587 - 0.0595)	1.481 (0.0595)	75	
1.501 - 1.520 (0.0595 - 0.0603)	1.501 (0.0603)	76	
1.521 - 1.540 (0.0603 - 0.0611)	1.521 (0.0611)	77	
1.541 - 1.560 (0.0611 - 0.0619)	1.541 (0.0619)	78	
1.561 - 1.580 (0.0619 - 0.0627)	1.561 (0.0627)	79	
1.581 - 1.600 (0.0627 - 0.0635)	1.581 (0.0635)	80	
1.601 - 1.620 (0.0635 - 0.0643)	1.601 (0.0643)	81	
1.621 - 1.640 (0.0643 - 0.0651)	1.621 (0.0651)	82	
1.641 - 1.660 (0.0651 - 0.0659)	1.641 (0.0659)	83	
1.661 - 1.680 (0.0659 - 0.0667)	1.661 (0.0667)	84	
1.681 - 1.700 (0.0667 - 0.0675)	1.681 (0.0675)	85	
1.701 - 1.720 (0.0675 - 0.0683)	1.701 (0.0683)	86	
1.721 - 1.740 (0.0683 - 0.0691)	1.721 (0.0691)	87	
1.741 - 1.760 (0.0691 - 0.0699)	1.741 (0.0699)	88	
1.761 - 1.780 (0.0699 - 0.0707)	1.761 (0.0707)	89	
1.781 - 1.800 (0.0707 - 0.0715)	1.781 (0.0715)	90	
1.801 - 1.820 (0.0715 - 0.0723)	1.801 (0.0723)	91	
1.821 - 1.840 (0.0723 - 0.0731)	1.821 (0.0731)	92	
1.841 - 1.860 (0.0731 - 0.0739)	1.841 (0.0739)	93	
1.861 - 1.880 (0.0739 - 0.0747)	1.861 (0.0747)	94	
1.881 - 1.900 (0.0747 - 0.0755)	1.881 (0.0755)	95	
1.901 - 1.920 (0.0755 - 0.0763)	1.901 (0.0763)	96	
1.921 - 1.940 (0.0763 - 0.0771)	1.921 (0.0771)	97	
1.941 - 1.960 (0.0771 - 0.0779)	1.941 (0.0779)	98	
1.961 - 1.980 (0.0779 - 0.0787)	1.961 (0.0787)	99	
1.981 - 2.000 (0.0787 - 0.0795)	1.981 (0.0795)	100	

Exhaust valve clearance (Cold):
0.25 - 0.35 mm (0.010 - 0.014 in.)

EXAMPLE: The 2.800 mm (0.1102 in.) shim is installed, and the measured clearance is 0.450 mm (0.0177 in.). Replace the 2.800 mm (0.1102 in.) shim with a new No.10 shim.

Shim No.	Thickness	Shim No.	Thickness
1	2.500 (0.0984)	10	2.950 (0.1161)
2	2.550 (0.1004)	11	3.000 (0.1181)
3	2.600 (0.1024)	12	3.050 (0.1201)
4	2.650 (0.1043)	13	3.100 (0.1220)
5	2.700 (0.1063)	14	3.150 (0.1240)
6	2.750 (0.1083)	15	3.200 (0.1260)
7	2.800 (0.1102)	16	3.250 (0.1280)
8	2.850 (0.1122)	17	3.300 (0.1299)
9	2.900 (0.1142)		

HINT: New shims have the thickness in millimeters imprinted on the face.

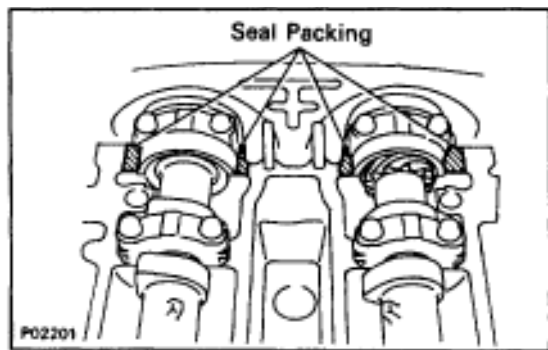

7. REINSTALL NO.2, NO.1 AND NO.3 CYLINDER HEAD COVERS

- (a) Remove any old packing (FIPG) material.
- (b) Apply seal packing to the cylinder head as shown in the illustration.

Seal packing:

Part No. 08826-00080 or equivalent

- (c) Install the gaskets to the No.1 and No.2 cylinder head covers.
- (d) Install the No.2 cylinder head cover with the 4 bolts.

Torque: 8.3 N·m (85 kgf·cm, 74 in.·lbf)

- (e) Install the No.1 cylinder head cover with the 4 bolts.

Torque: 8.3 N·m (85 kgf·cm, 74 in.·lbf)

- (f) Install the No.3 cylinder head cover with the 4 bolts and 4 nuts.

Torque: 8.3 N·m (85 kgf·cm, 74 in.·lbf)

8. RECONNECT HIGH-TENSION CORDS TO CYLINDER HEAD COVERS

(See high-tension cords and cord clamps installation in Ignition System)

9. REINSTALL THROTTLE BODY AND INTAKE AIR CONNECTOR ASSEMBLY

(See steps 8 to 17 in injector installation in SFI System)

VALVE CLEARANCE INSPECTION AND ADJUSTMENT (2JZ-GTE)

HINT: Inspect and adjust the valve clearance when the engine is cold.

1. REMOVE IGNITION COILS ASSEMBLIES

(See ignition coils removal in Ignition System)

2. DISCONNECT ENGINE WIRE PROTECTOR FROM NO.4 TIMING BELT COVER

- (a) Disconnect the engine wire from the 4 wire clamps.
- (b) Lift out the engine wire protector from the cylinder head covers.

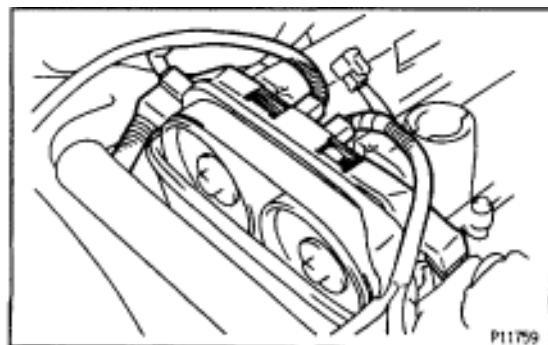

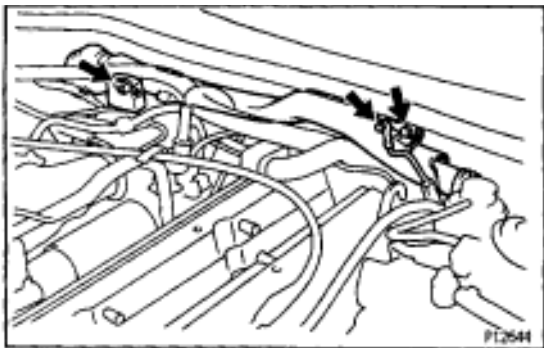

3. DISCONNECT ENGINE WIRE PROTECTOR FROM COWL TOP PANEL

- (a) Remove the bolt, and disconnect the ground strap.
- (b) Remove the 2 bolts, and lift up the engine wire protector.

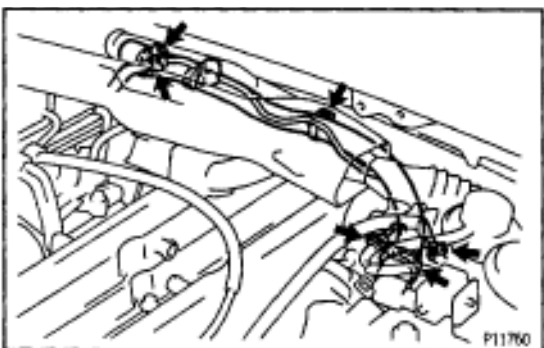

4. REMOVE IAC VALVE PIPE

- (a) Disconnect the 5 air hoses from the IAC valve pipe.
- (b) Remove the IAC valve pipe from the pipe clamp on the No.1 cylinder head cover.

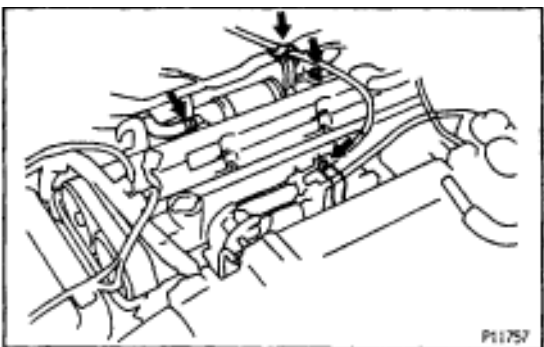

5. REMOVE NO.1 AND NO.2 CYLINDER HEAD COVERS

- (a) Disconnect the cruise control actuator cable from the cable bracket.
- (b) Remove the bolt holding the VSV to the turbo outlet duct.
- (c) Disconnect the 2 PCV hoses from the cylinder head covers.

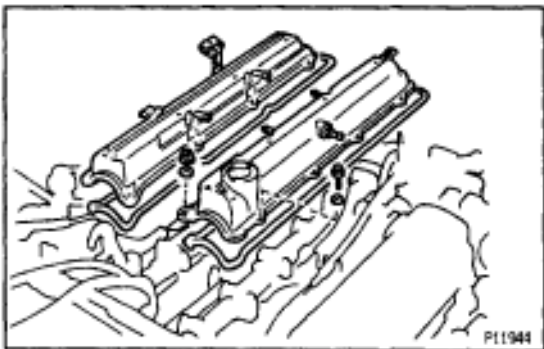

- (d) Remove the 6 bolts, 2 nuts, 8 seal washers, No.1 cylinder head cover and gasket.
- (e) Remove the 6 bolts, 2 nuts, 8 seal washers, No.2 cylinder head cover and gasket.

6. SET NO.1 CYLINDER TO TDC/COMPRESSION

(See step 4 in valve clearance inspection and adjustment (2JZ-GE))

7. INSPECT VALVE CLEARANCE

(See step 5 in valve clearance inspection and adjustment (2JZ-GE))

8. ADJUST VALVE CLEARANCE

(See step 6 in valve clearance inspection and adjustment (2JZ-GE))

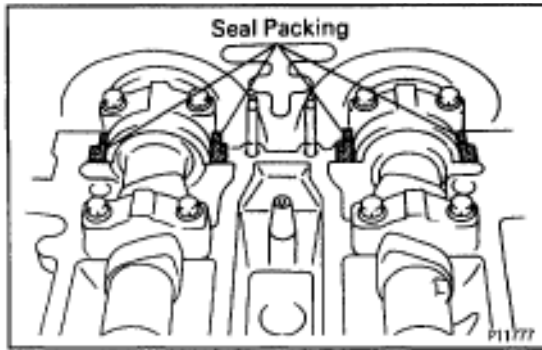

9. REINSTALL NO.1 AND NO.2 CYLINDER HEAD COVERS

- (a) Remove any old packing (FIPG) material.
- (b) Apply seal packing to the cylinder head as shown in the illustration.

Seal packing:

Part No. 08826-00080 or equivalent

- (c) Install the gaskets to the No.1 and No.2 cylinder head covers.
- (d) Install the 12 seal washers to the bolts.
- (e) Install the No.2 cylinder head cover with the 6 bolts, 4 seal washers and 4 nuts.

Torque: 5.4 N·m (55 kgf·cm, 48 in·lbf)

- (f) Install the No.1 cylinder head cover with the 6 bolts, 4 seal washers and 4 nuts.

Torque: 5.4 N·m (55 kgf·cm, 48 in·lbf)

- (g) Connect the 2 PCV hoses to the cylinder head covers.
- (h) Install the bolt holding the VSV to the turbo outlet duct.
- (i) Connect the cruise control actuator cable to the cable bracket.

10. RECONNECT ENGINE WIRE PROTECTOR TO NO.4 TIMING BELT COVER

11. REINSTALL IAC VALVE PIPE

12. RECONNECT ENGINE WIRE PROTECTOR TO COWL TOP PANEL

13. REINSTALL IGNITION COILS ASSEMBLIES

(See ignition coils installation in Ignition System)

IGNITION TIMING INSPECTION AND ADJUSTMENT (2JZ-GE)

1. WARM UP ENGINE

Allow the engine to warm up to normal operating temperature.

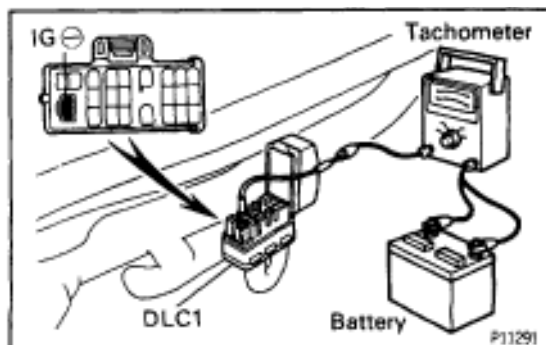

2. CONNECT TACHOMETER AND TIMING LIGHT

Connect the tester probe of a tachometer to terminal IG ⊖ of the DLC1.

NOTICE:

- Never allow the tachometer terminal to touch ground as it could result in damage to the Igniter and/or ignition coil.
- As some tachometers are not compatible with this ignition system, we recommend that you confirm the compatibility of your unit before use.

3. CHECK IDLE SPEED

- (a) Race the engine speed at 2,500 rpm for approx. 90 seconds.
- (b) Check the idle speed.

Idle speed:

700 ± 50 rpm

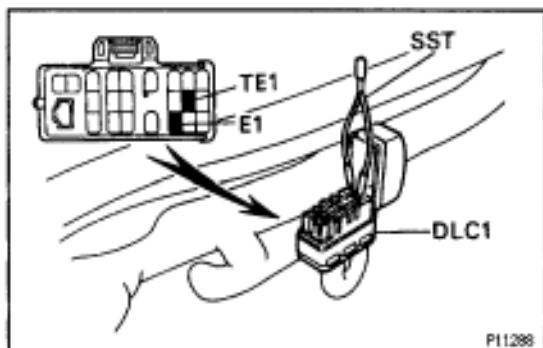
**4. ADJUST IGNITION TIMING**

- (a) Using SST, connect terminals TE1 and E1 of the DLC 1.
SST 09843-18020

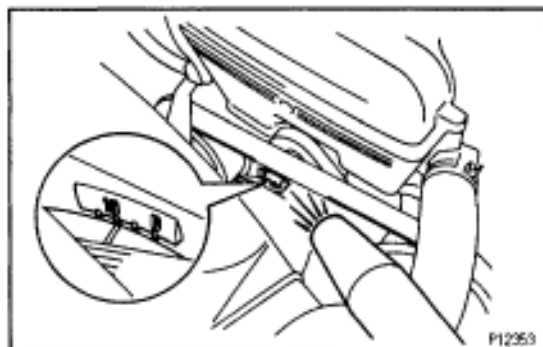

- (b) Using a timing light, check the ignition timing.
Ignition timing:

10 ± 2° BTDC @ idle

(Transmission in neutral position)

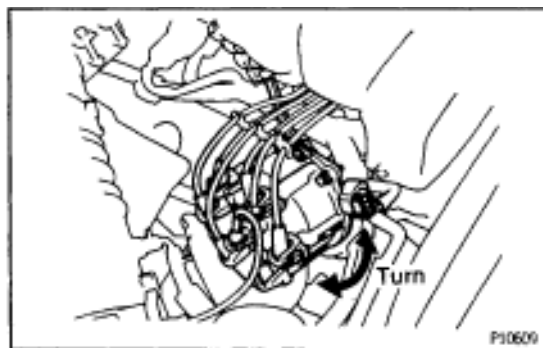

- (c) Loosen the nut, and adjust by turning the distributor.
Ignition timing:

10° BTDC @ idle

(Transmission in neutral position)

- (d) Tighten the nut, and recheck the ignition timing.
Torque: 19 N·m (195 kgf·cm, 14 ft·lbf)
- (e) Remove the SST from the DLC1.
SST 09843-18020

5. FURTHER CHECK IGNITION TIMING

Ignition timing:

7-19° BTDC @ idle

(Transmission in neutral position)

HINT: The timing mark moves in a range between 7° and 19°.

6. DISCONNECT TACHOMETER AND TIMING LIGHT

IGNITION TIMING INSPECTION (2JZ-GTE)

1. WARM UP ENGINE

Allow the engine to warm up to normal operating temperature.

2. CONNECT TACHOMETER AND TIMING LIGHT

(See step 2 in ignition timing inspection and adjustment (2JZ-GE))

3. CHECK IDLE SPEED

(a) Race the engine speed at 2,500 rpm for approx. 90 seconds.

(b) Check the idle speed.

Idle speed:

650 ± 50 rpm

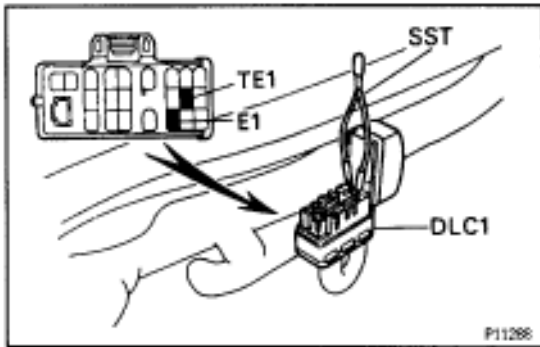

4. CHECK IGNITION TIMING

(a) Using SST, connect terminals TE1 and E1 of the DLC 1. SST 09843-18020

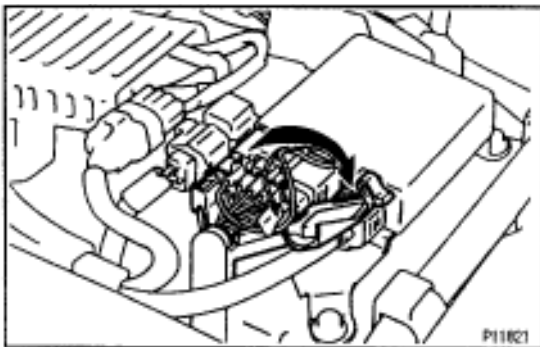

(b) Open the igniter connector cover and remove the green lead wire.

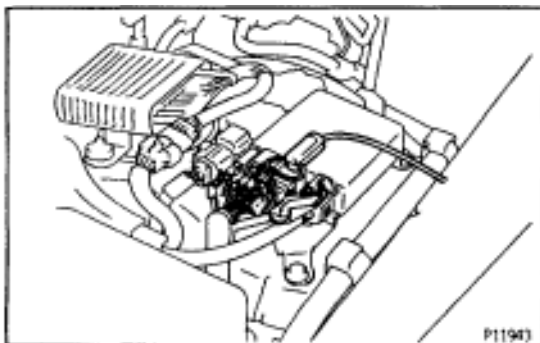

(c) Connect the timing light clip to the green lead wire.

NOTICE:

- Use a timing light that can detect the primary signal.
- After finishing the inspection, make sure the lead wire is stored inside the connector cover.

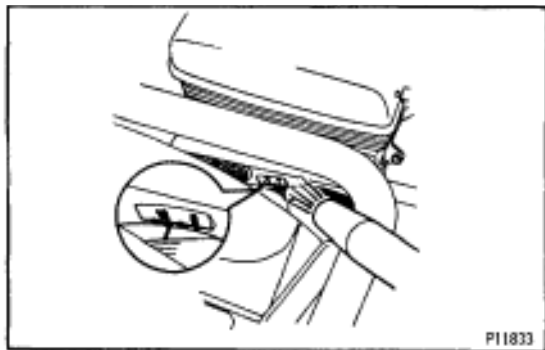

- (d) Using a timing light, check the ignition timing.

Ignition timing:

$10 \pm 2^\circ$ BTDC @ idle

(Transmission in neutral position)

If the ignition timing is not as specified, check the valve timing. (See step 14 in timing belt installation)

- (e) Remove the SST from the DLC1.

SST 09843-18020

5. FURTHER CHECK IGNITION TIMING

Ignition timing:

$10-20^\circ$ BTDC @ idle

(Transmission in neutral position)

HINT: The timing mark moves in a range between 10° and 20° .

6. DISCONNECT TACHOMETER AND TIMING LIGHT

IDLE SPEED INSPECTION

1. INITIAL CONDITIONS

- (a) Engine at normal operating temperature
- (b) Air cleaner installed
- (c) All pipes and hoses of air induction system connected
- (d) All accessories switched OFF
- (e) All vacuum lines properly connected

HINT: All vacuum hoses for EGR system, etc. should be properly connected.

- (f) SFI system wiring connectors fully plugged
- (g) Ignition timing set correctly
- (h) Transmission in neutral position

2. CONNECT TACHOMETER

(See step 2 in ignition timing inspection and adjustment (2JZ-GE))

3. INSPECT IDLE SPEED

- (a) Race the engine speed at 2,500 rpm for approx. 90 seconds.
- (b) Check the idle speed.

Idle speed:

2JZ-GE

700 ± 50 rpm

2JZ-GTE

650 ± 50 rpm

If the idle speed is not as specified, check the IAC valve. (See on-vehicle inspection in ISC valve in SFI System)

4. DISCONNECT TACHOMETER

TIMING BELT COMPONENTS FOR REMOVAL AND INSTALLATION

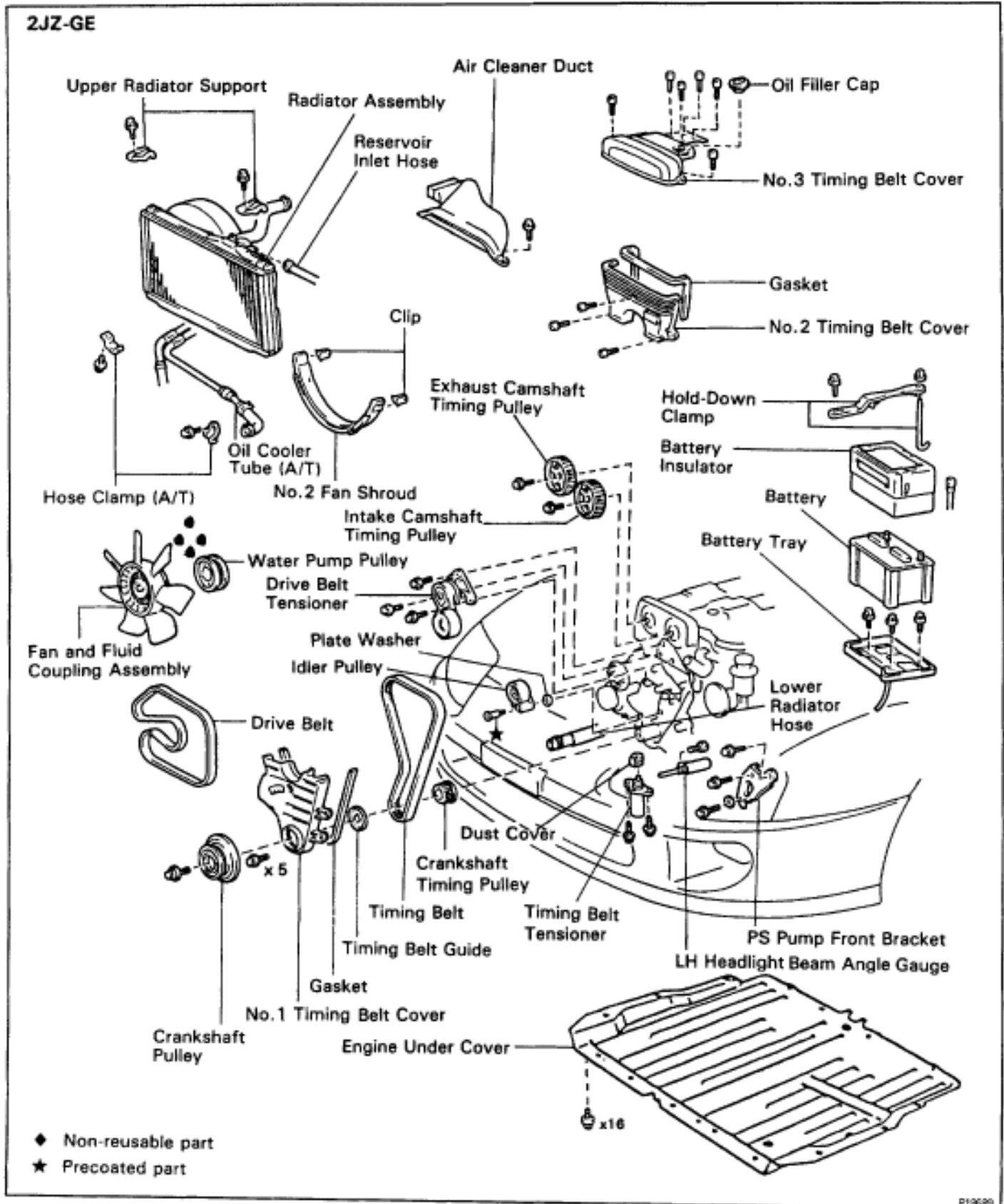

2JZ-GTE

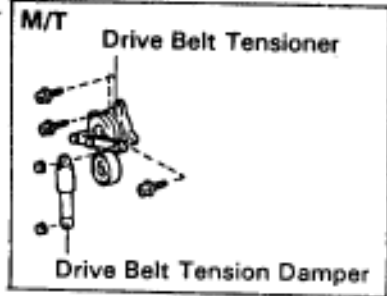
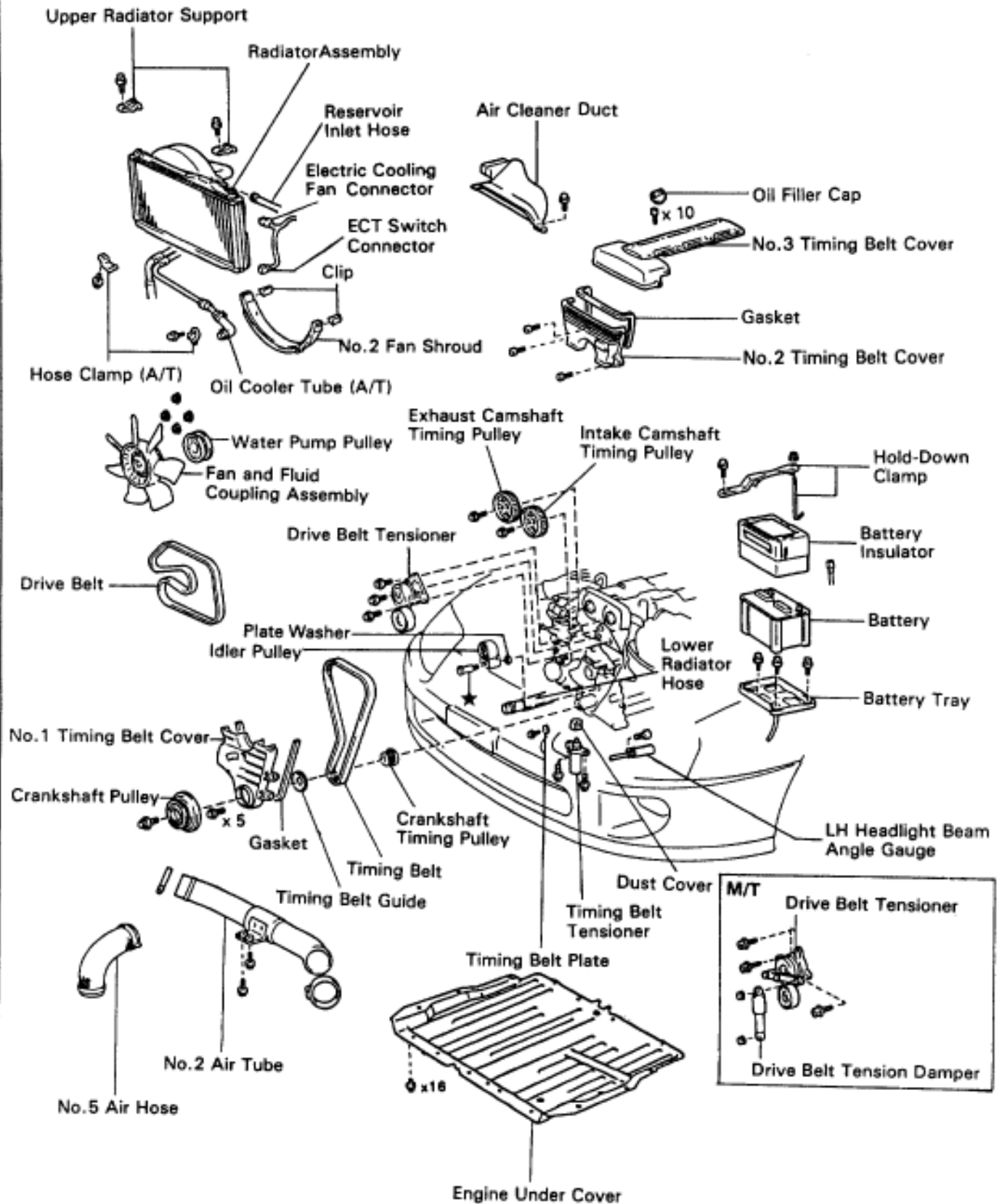

- ◆ Non-reusable part
- ★ Precoated part

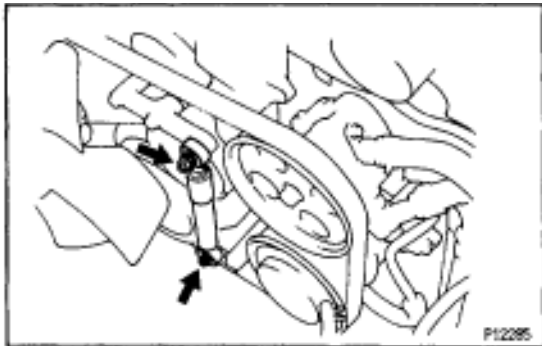

TIMING BELT REMOVAL

1. **REMOVE RADIATOR ASSEMBLY**
(See radiator removal in Cooling System)
2. **2JZ-GTE M/T:**
REMOVE DRIVE BELT TENSIONER DAMPER
Remove the 2 nuts and tensioner damper.
3. **REMOVE DRIVE BELT, FAN, FLUID COUPLING ASSEMBLY AND WATER PUMP PULLEY**
(See step 6 in water pump removal in Cooling System)



4. **REMOVE NO.3 TIMING BELT COVER**
 - (a) Remove the oil filler cap.
 - (b) **2JZ-GE:**
Using a 5 mm hexagon wrench, remove the 6 bolts and belt cover.

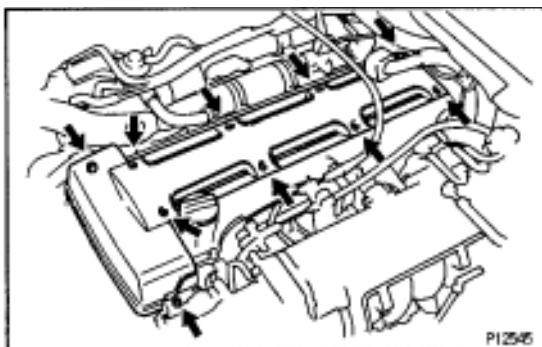

- (c) **2JZ-GTE:**
Using a 5 mm hexagon wrench, remove the 10 bolts and belt cover.

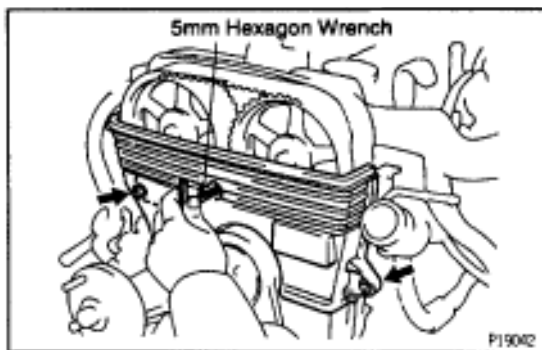

5. **REMOVE NO.2 TIMING BELT COVER**
Using a 5 mm hexagon wrench, remove the 3 bolts, belt cover and gasket.
If you are unable to loosen the bolt on the right because the PS pump pulley interferes with the hexagon wrench, first remove the pulley.

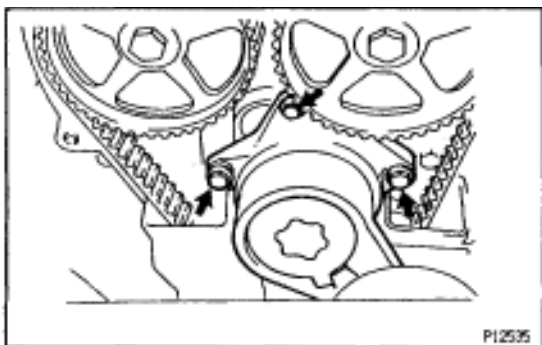

6. **REMOVE DRIVE BELT TENSIONER**
Remove the 3 bolts and tensioner.



7. SET NO.1 CYLINDER TO TDC/COMPRESSION

- (a) Turn the crankshaft pulley, and align its groove with timing mark "O" of the No.1 timing belt cover.

NOTICE: Always turn the crankshaft clockwise.

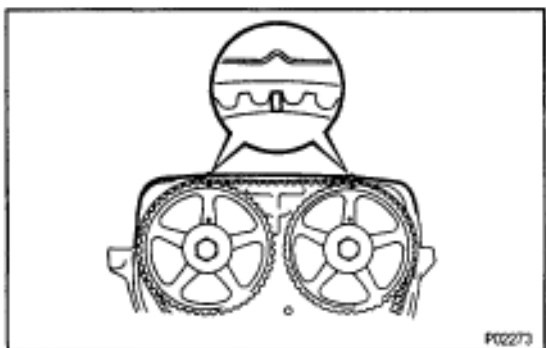

- (b) Check that the timing marks of the camshaft timing pulleys are aligned with the timing marks of the No.4 timing belt cover.

If not, turn the crankshaft 1 revolution (360°).

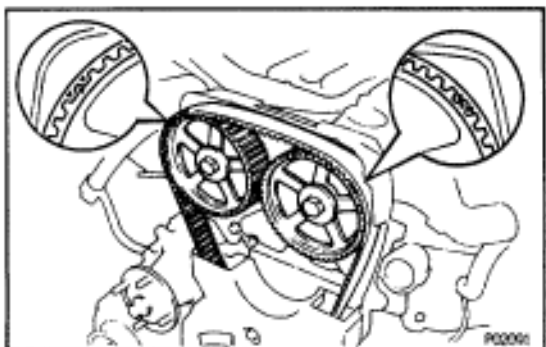

8. REMOVE TIMING BELT FROM CAMSHAFT TIMING PULLEYS

HINT (Re-using timing belt): Place matchmarks on the timing belt and camshaft timing pulleys as shown in the illustration.

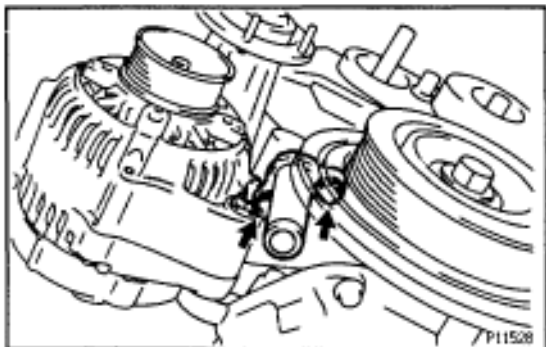

- (a) Alternately loosen the 2 bolts, and remove them, the tensioner and dust boot.



- (b) Disconnect the timing belt from the camshaft timing pulleys.

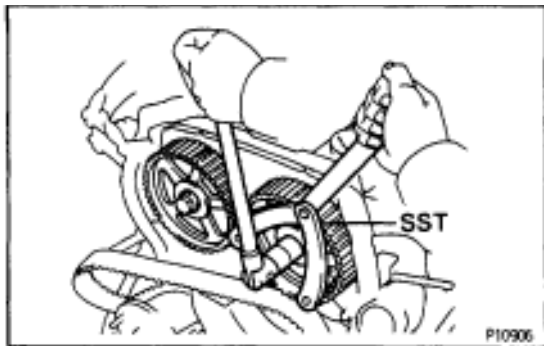

9. REMOVE CAMSHAFT TIMING PULLEYS

Using SST, remove the pulley bolt. Remove the 2 timing pulleys.

SST 09960-10010 (09962-01000, 09963-01000)

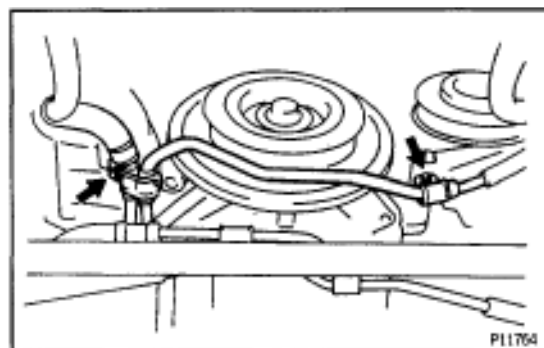

10. A/T:

DISCONNECT OIL COOLER TUBES

Remove the 2 bolts and hose clamps, and disconnect oil cooler tubes.

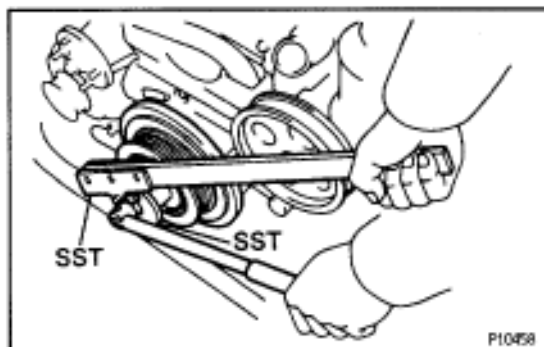

11. REMOVE CRANKSHAFT PULLEY

(a) Using SST, loosen the pulley bolt.

SST 09213-70010, 09330-00021

(b) Remove the pulley bolt.

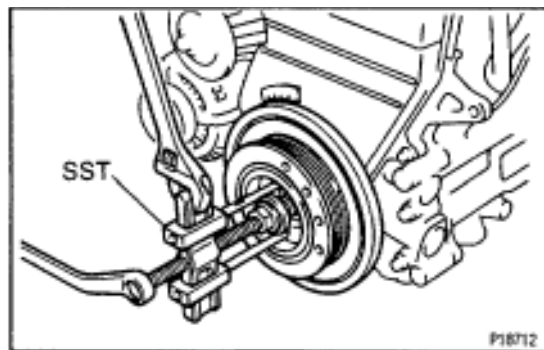

(c) Using SST, remove the pulley.

SST 09950-50010 (09954-05030, 09551-05010, 09552-05010, 09553-05020)

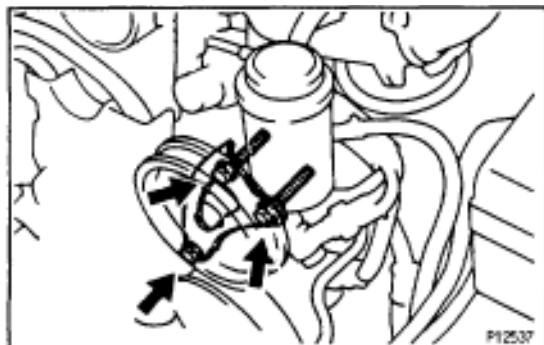

12. 2JZ-GE:

REMOVE PS PUMP FRONT BRACKET

Remove the 3 bolts, plate washer and pump front bracket.

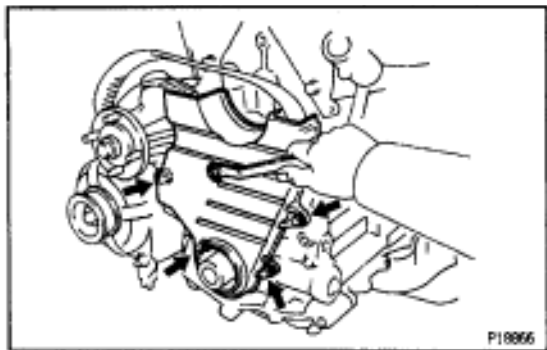
**13. REMOVE NO.1 TIMING BELT COVER**

Remove the 5 bolts, timing belt cover and gasket.

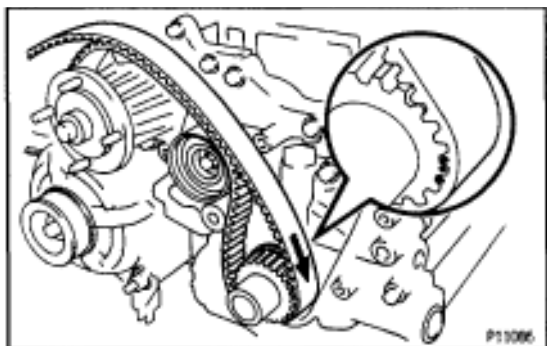
14. REMOVE TIMING BELT GUIDE**15. REMOVE TIMING BELT**

HINT (When re-using timing belt): Draw an arrow on the timing belt in the direction of engine revolution, and place match-marks on the timing belt and crankshaft timing pulley.

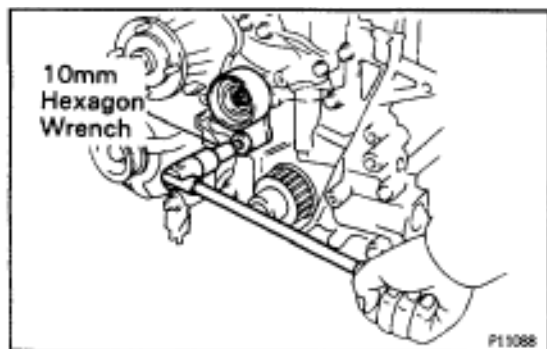
**16. REMOVE IDLER PULLEY**

Using a 10 mm hexagon wrench, remove the pivot bolt, plate washer and idler pulley.

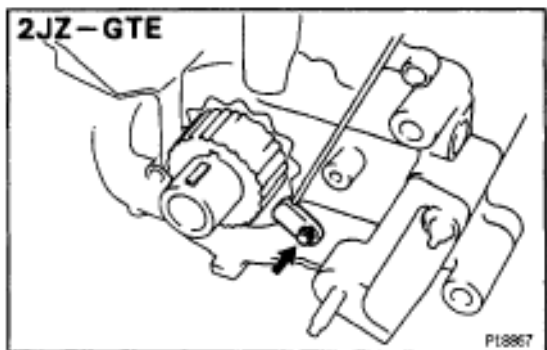
**17. REMOVE CRANKSHAFT TIMING PULLEY****(a) 2JZ-GTE:**

Remove the bolt and timing belt plate.

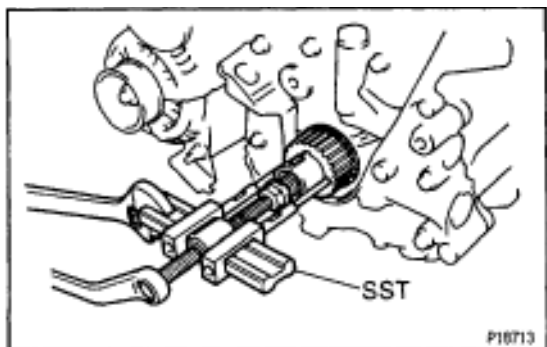
**(b) Remove the crankshaft timing pulley.**

If the pulley cannot be removed by hand, use SST to remove the crankshaft timing pulley.

SST 09950-50010 (09951-05010, 09952-05010, 09953-05020, 09954-00010)

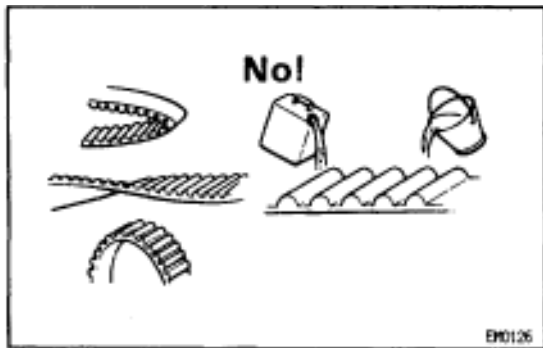

TIMING BELT COMPONENTS INSPECTION

1. INSPECTION TIMING BELT

NOTICE:

- Do not bend, twist or turn the timing belt inside out.
- Do not allow the timing belt to come into contact with oil, water or steam.
- Do not utilize timing belt tension when installing or removing the mount bolt of the camshaft timing pulley.

If there are any defects, as shown in the illustrations, check the following points.

- (a) Premature parting
 - Check for proper installation.
 - Check the timing cover gasket for damage and proper installation.
- (b) If the belt teeth are cracked or damaged, check to see if either camshaft is locked.
- (c) If there is noticeable wear or cracks on the belt face, check to see if there are nicks on the side of the idler pulley lock.
- (d) If there is wear or damage on only one side of the belt, check the belt guide and the alignment of each pulley.
- (e) If there is noticeable wear on the belt teeth, check timing cover for damage and check gasket has been installed correctly and for foreign material on the pulley teeth. If necessary, replace the timing belt.

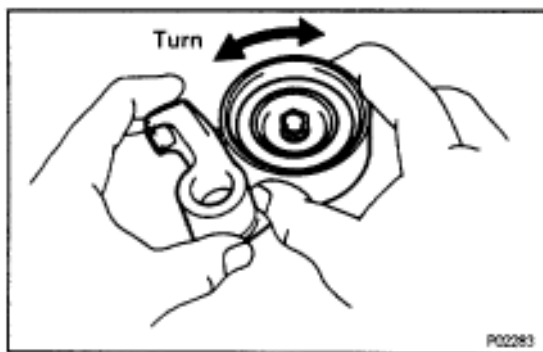

2. INSPECT IDLER PULLEY

Check the turning smoothness of the idler pulley. If necessary, replace the idler pulley.

3. INSPECT DRIVE BELT TENSIONER

Check the turning smoothness of the tensioner. If necessary, replace the tensioner.

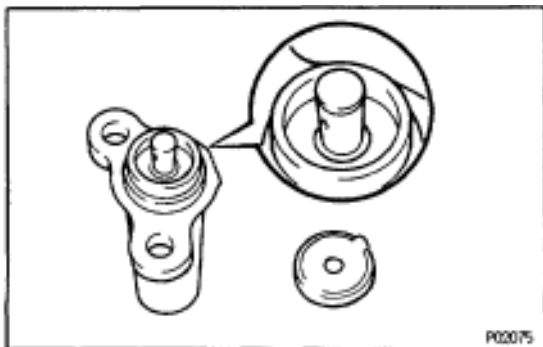

4. INSPECT TIMING BELT TENSIONER

- (a) Visually check tensioner for oil leakage.

HINT: If there is only the faintest trace of oil on the seal on the push rod side, the tensioner is all right. If leakage is found, replace tensioner.

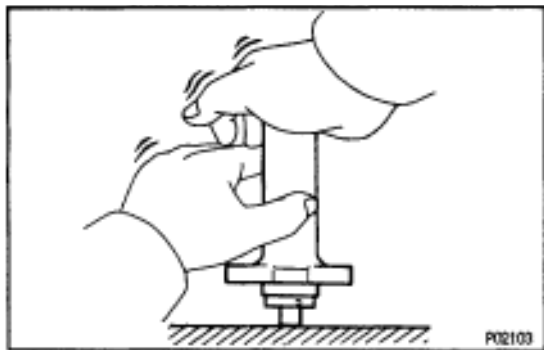

- (b) Hold the tensioner with both hands and push the push rod strongly against the floor or wall to check that it doesn't move. If the push rod moves, replace the tensioner.

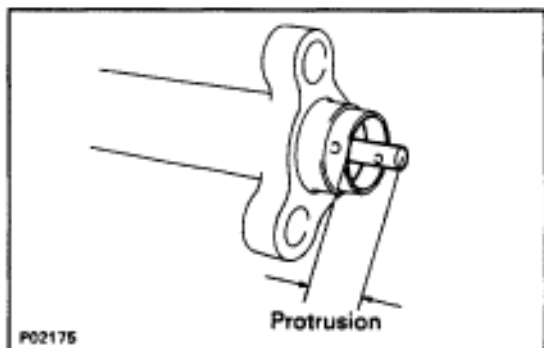

- (c) Measure the protrusion of the push rod from the housing end.
Protrusion:

8.0–8.8 mm (0.315–0.346 in.)

If the protrusion is not as specified, replace the tensioner.

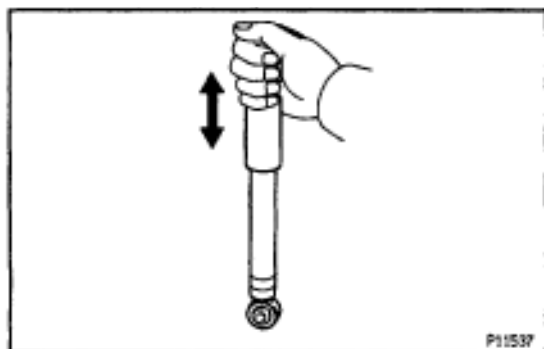

**5. 2JZ-GTE M/T:
INSPECT DRIVE BELT TENSION DAMPER**

Compress and extend the tension damper rod and check that there is no abnormal resistance or unusual operation sounds.

If there is any abnormality, replace the tension damper with a new one.

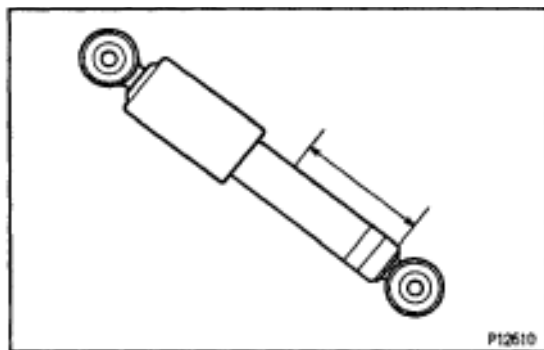

NOTICE: When discarding the tension damper, use the following procedure.

- Fully extend the damper rod.
- Using a drill, make a hole in the cylinder as shown to release the gas inside.

CAUTION: The gas coming out is harmless, but be careful of the chips which may fly up when drilling.

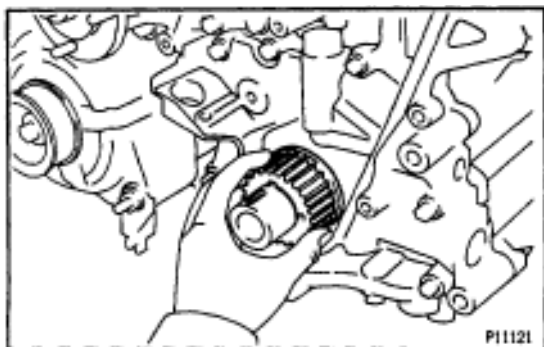

TIMING BELT INSTALLATION

1. INSTALL CRANKSHAFT TIMING PULLEY

- Align the pulley set key with the key groove of the pulley.
- Slide on the timing pulley facing the flange side inward.

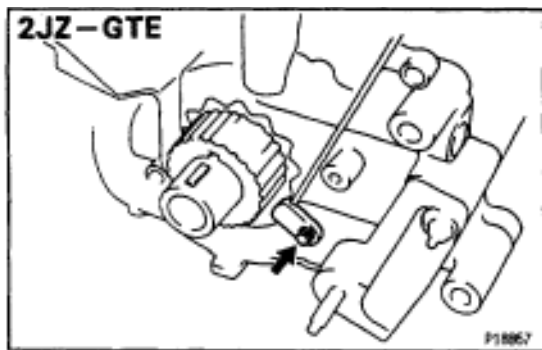

- (c) 2JZ-GTE:
Install the timing belt plate with the bolt.
Torque: 7.8 N·m (80 kgf·cm, 69 in·lbf)

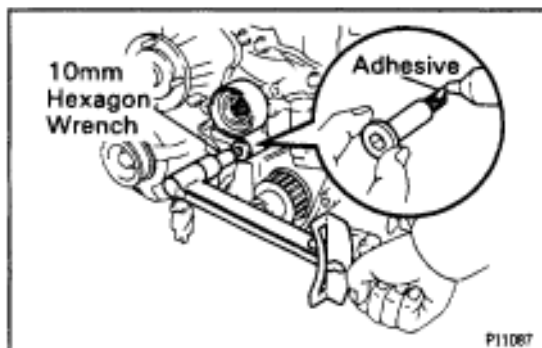

2. INSTALL IDLER PULLEY

- (a) Apply adhesive to 2 or 3 threads of the pivot bolt.
Adhesive:
Part No. 08833-00080, THREE BOND 1344, LOCTITE 242 or equivalent
- (b) Using a 10 mm hexagon wrench, install the plate washer and pulley with the pivot bolt.
Torque: 34 N·m (350 kgf·cm, 25 ft·lbf)
- (c) Check that the pulley bracket moves smoothly.

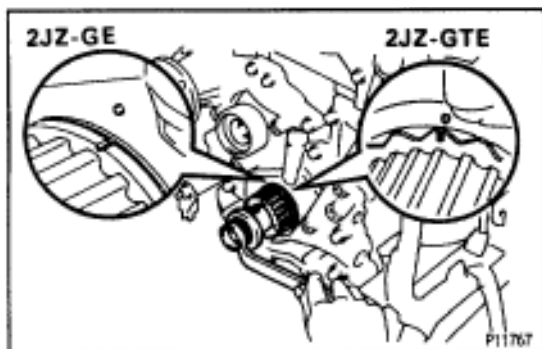

3. TEMPORARILY INSTALL TIMING BELT

NOTICE: The engine should be cold.

- (a) Using the crankshaft pulley bolt, turn the crankshaft, and align the timing marks on the crankshaft timing pulley and on the oil pump body.
- (b) Remove any oil or water on the crankshaft timing pulley and idler pulley, and keep them clean.

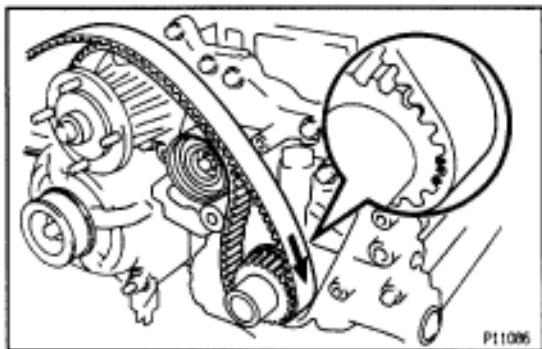

- (c) Install the timing belt on the crankshaft timing pulley and idler pulley.
HINT (When re-using timing belt): Align the match marks of the crankshaft timing pulley and timing belt, and install the belt with the arrow pointing in the direction of engine revolution.

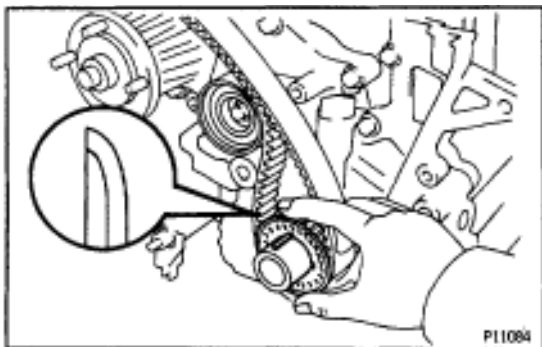

4. INSTALL TIMING BELT GUIDE

Install the guide, facing the cup side outward.

5. INSTALL NO.1 TIMING BELT COVER



6. 2JZ-GE:

INSTALL PS PUMP FRONT BRACKET

- (a) Install the pump front bracket with the 2 bolts (A).
Torque: 58 N·m (590 kgf·cm, 43 ft·lbf)
- (b) Install the plate washer and bolt (b) to the oil pump.
Torque: 52 N·m (530 kgf·cm, 38 ft·lbf)

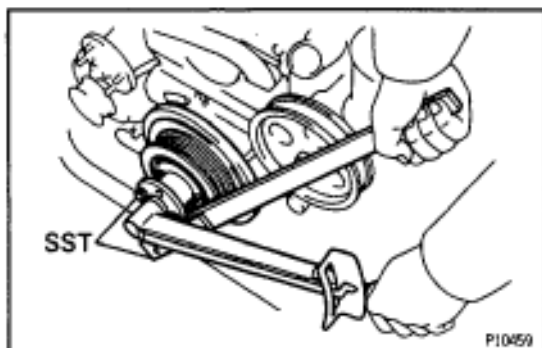

7. INSTALL CRANKSHAFT PULLEY

- (a) Align the pulley set key with the key groove of the pulley, and slide on the pulley.
- (b) Using SST, install the bolt.
SST 09213-70010, 09330-00021
Torque: 324 N·m (3,300 kgf·cm, 239 ft·lbf)

8. A/T:

CONNECT OIL COOLER TUBES

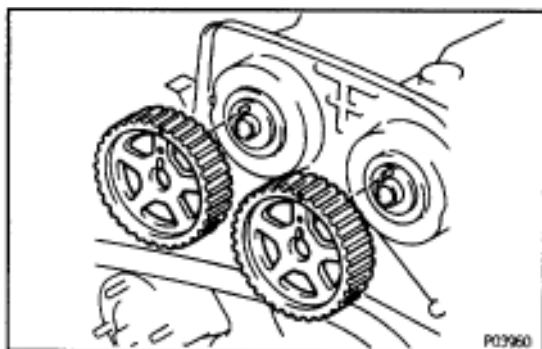

9. INSTALL CAMSHAFT TIMING PULLEYS

- (a) Align the camshaft knock pin with the groove of the pulley, and slide on the timing pulley.
- (b) Temporarily install the timing pulley bolt.

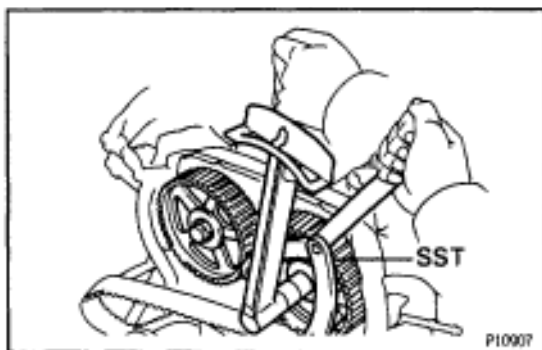

- (c) Using SST, tighten the pulley bolt.
SST 09960-10010 (09962-01000, 09963-01000)
Torque: 79 N·m (810 kgf·cm, 59 ft·lbf)



10. SET NO.1 CYLINDER TO TDC/COMPRESSION

- (a) Turn the crankshaft pulley, and align its groove with timing mark "O" of the No.1 timing belt cover.
NOTICE: Always turn the crankshaft clockwise.

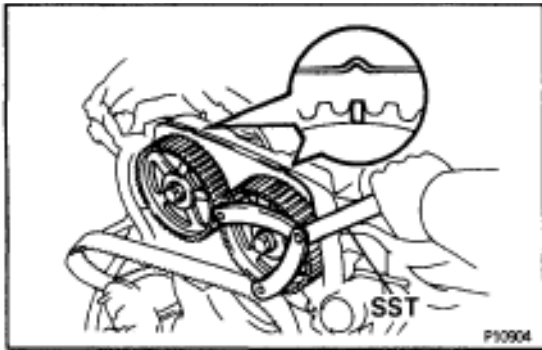

- (b) Using SST, align the timing marks of the camshaft timing pulleys and No.4 timing belt cover.
SST 09960-10010 (09962-01000, 09963-01000)

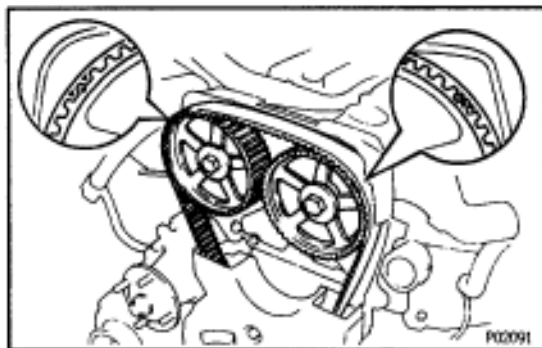

11. INSTALL TIMING BELT

HINT (When re-using timing belt): Align the matchmarks of the timing belt and camshaft timing pulleys.

- (a) Remove any oil or water on the camshaft timing pulley, and keep it clean.
(b) Install the timing belt, checking the tension between the crankshaft timing pulley and exhaust camshaft timing pulley.

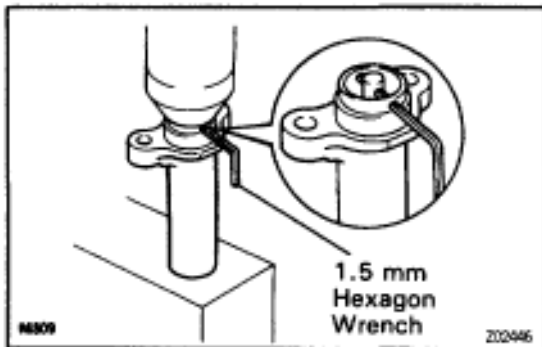

12. SET TIMING BELT TENSIONER

- (a) Using a press, slowly press in the push rod using 981 –9,807 N (100–1,000 kgf, 220–2,205 lbf) of force.
(b) Align the holes of the push rod and housing, pass a 1.5 mm hexagon wrench through the holes to keep the push rod retracted.
(c) Release the press.

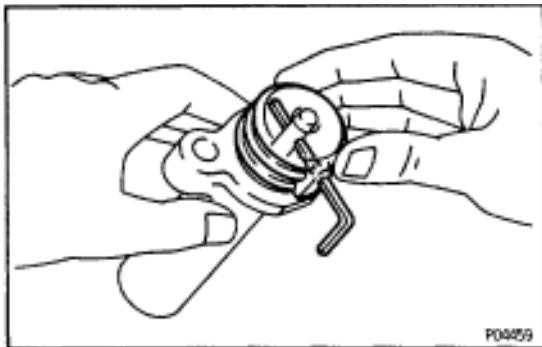

- (d) Install the dust boot onto the tensioner.

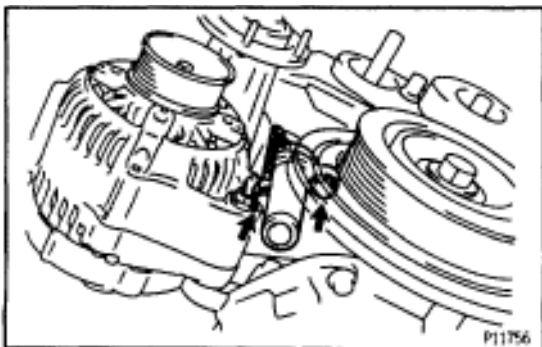

13. INSTALL TIMING BELT TENSIONER

- (a) Temporarily install the tensioner with the 2 bolts.
(b) Alternately tighten the 2 bolts.
Torque: 26 N·m (270 kgf·cm, 20 ft·lbf)

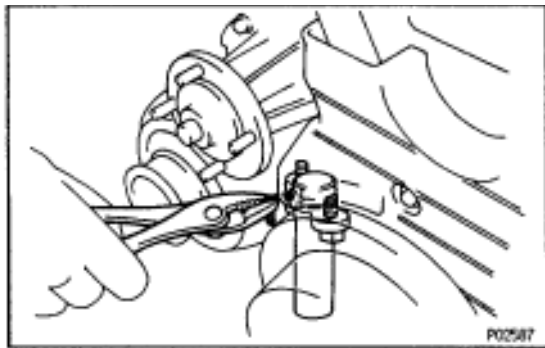

- (c) Remove the 1.5 mm hexagon wrench from the tensioner.

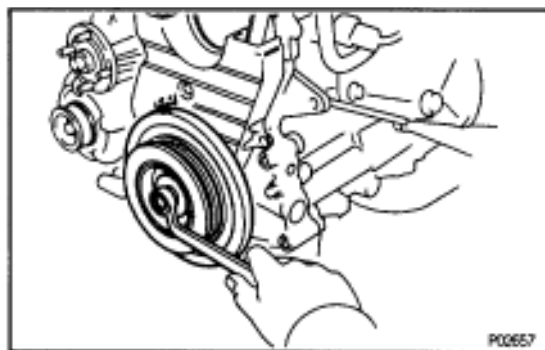

14. CHECK VALVE TIMING

- (a) Slowly turn the crankshaft pulley 2 revolutions from TDC to TDC.

NOTICE: Always turn the crankshaft clockwise.

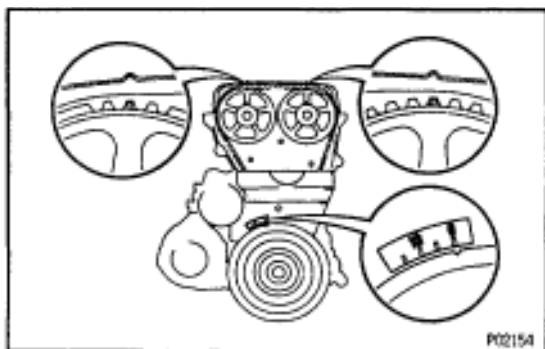

- (b) Check that each pulley aligns with the timing marks as shown in the illustration.

If the marks do not align, remove the timing belt and reinstall it.

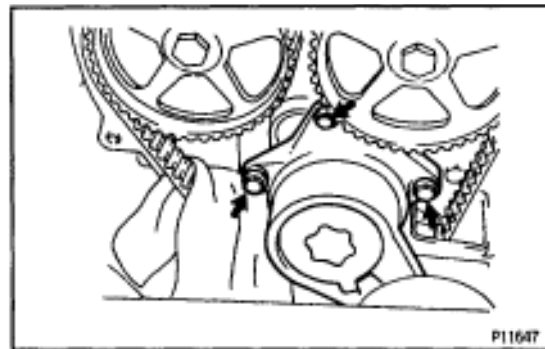

15. INSTALL DRIVE BELT TENSIONER

Install the tensioner with the 3 bolts.

Torque: 21 N·m (210 kgf·cm, 15 ft·lbf)

NOTICE: Be careful not to drop the bolts inside the timing belt cover.

16. INSTALL NO.2 TIMING BELT COVER

17. INSTALL NO.3 TIMING BELT COVER

18. INSTALL WATER PUMP PULLEY, FAN, FLUID COUPLING ASSEMBLY AND DRIVE BELT

(See step 10 in water pump installation in Cooling System)

19. 2JZ-GTE M/T:

INSTALL DRIVE BELT TENSIONER DAMPER

Torque: 20 N·m (200 kgf·cm, 14 ft·lbf)

20. INSTALL RADIATOR ASSEMBLY

(See radiator installation in Cooling System)

21. ROAD TEST VEHICLE

Check for abnormal noise, shock, slippage, correct shift points and smooth operation.

CYLINDER HEAD COMPONENTS FOR REMOVAL AND INSTALLATION

2JZ-GE

Air Cleaner, VAF Meter and Intake Air Connector Pipe Assembly

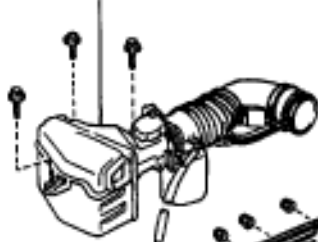

Exhaust Manifold
Heat Insulator
(Except California)
Exhaust Manifold



◆ Gasket

Air Cleaner Duct

Cruise Control Actuator Cable
Throttle Control Cable (A/T)
Accelerator Cable

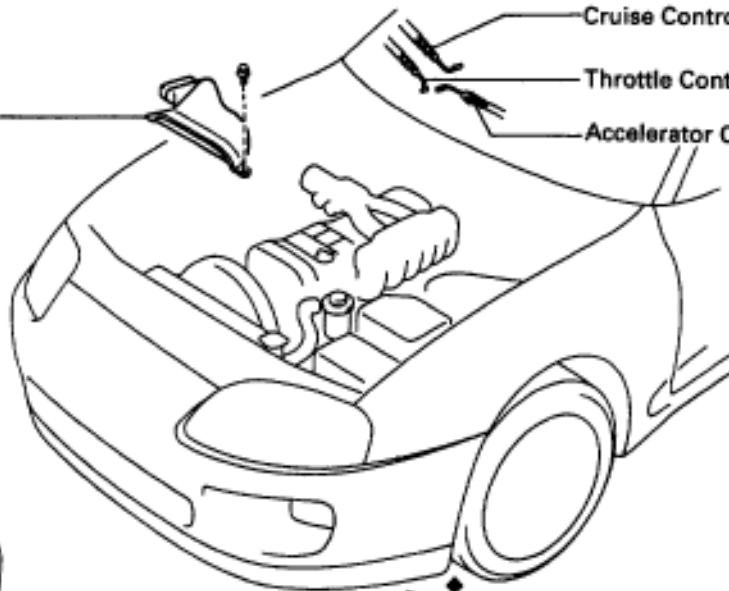

Drive Belt



◆ Gasket

◆ Gasket

No.2 Front Exhaust Pipe

Pipe Support Bracket

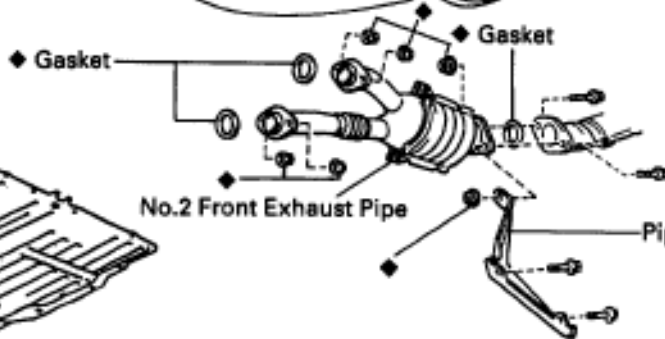

Engine Under Cover

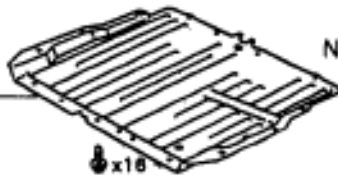

x18

◆ Non-reusable part

2JZ-GE

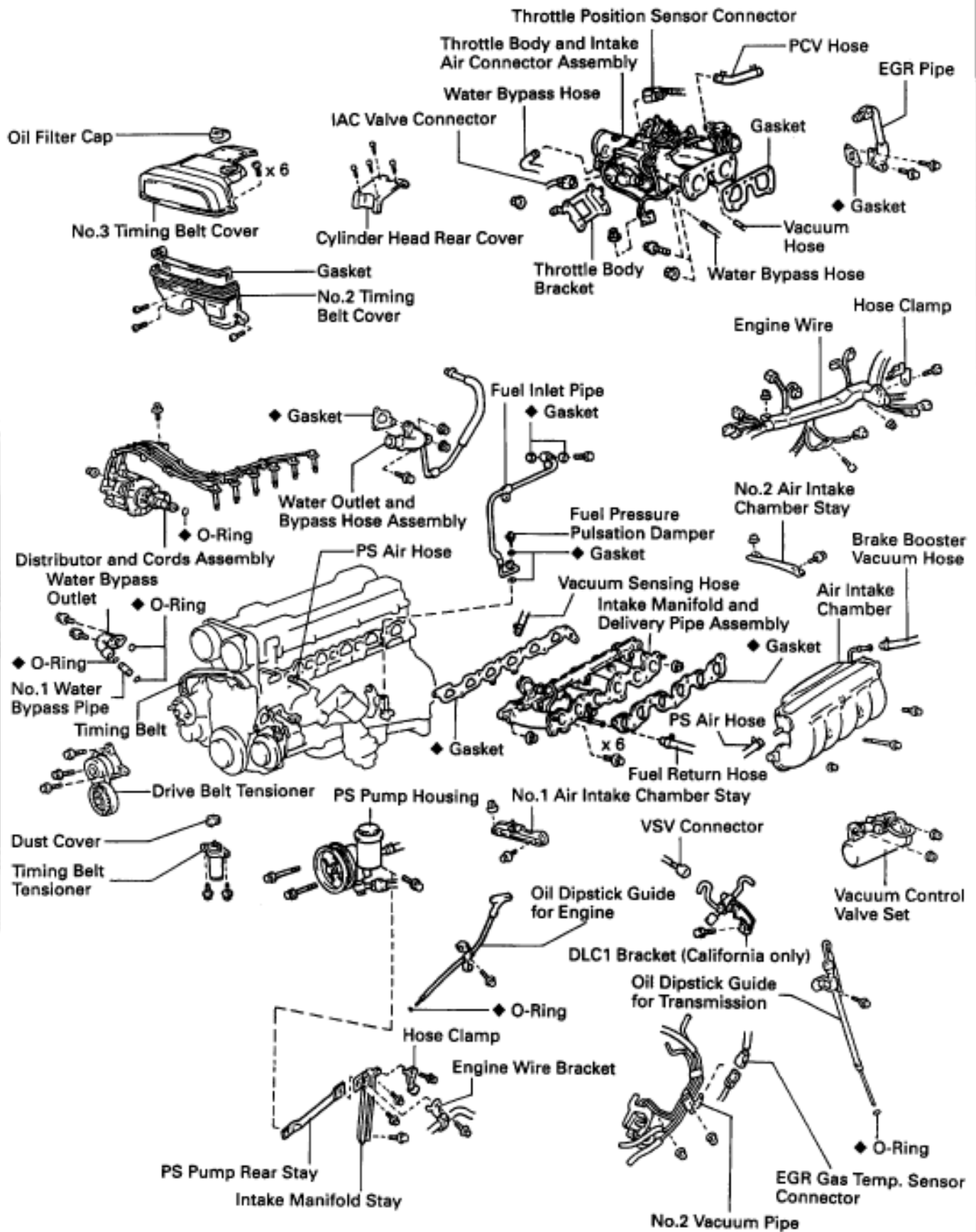

2JZ-GE

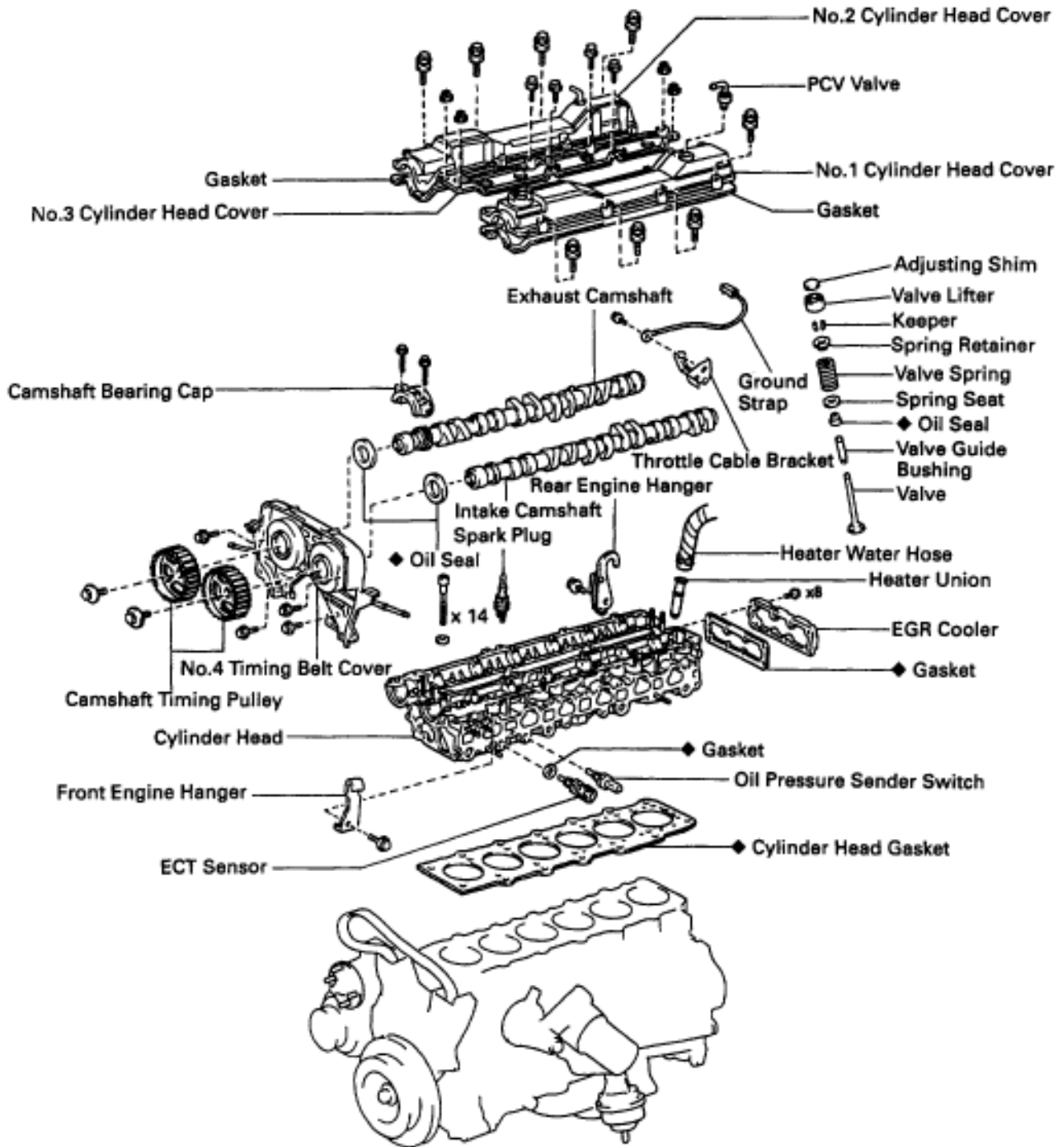

◆ Non-reusable part

2JZ - GTE

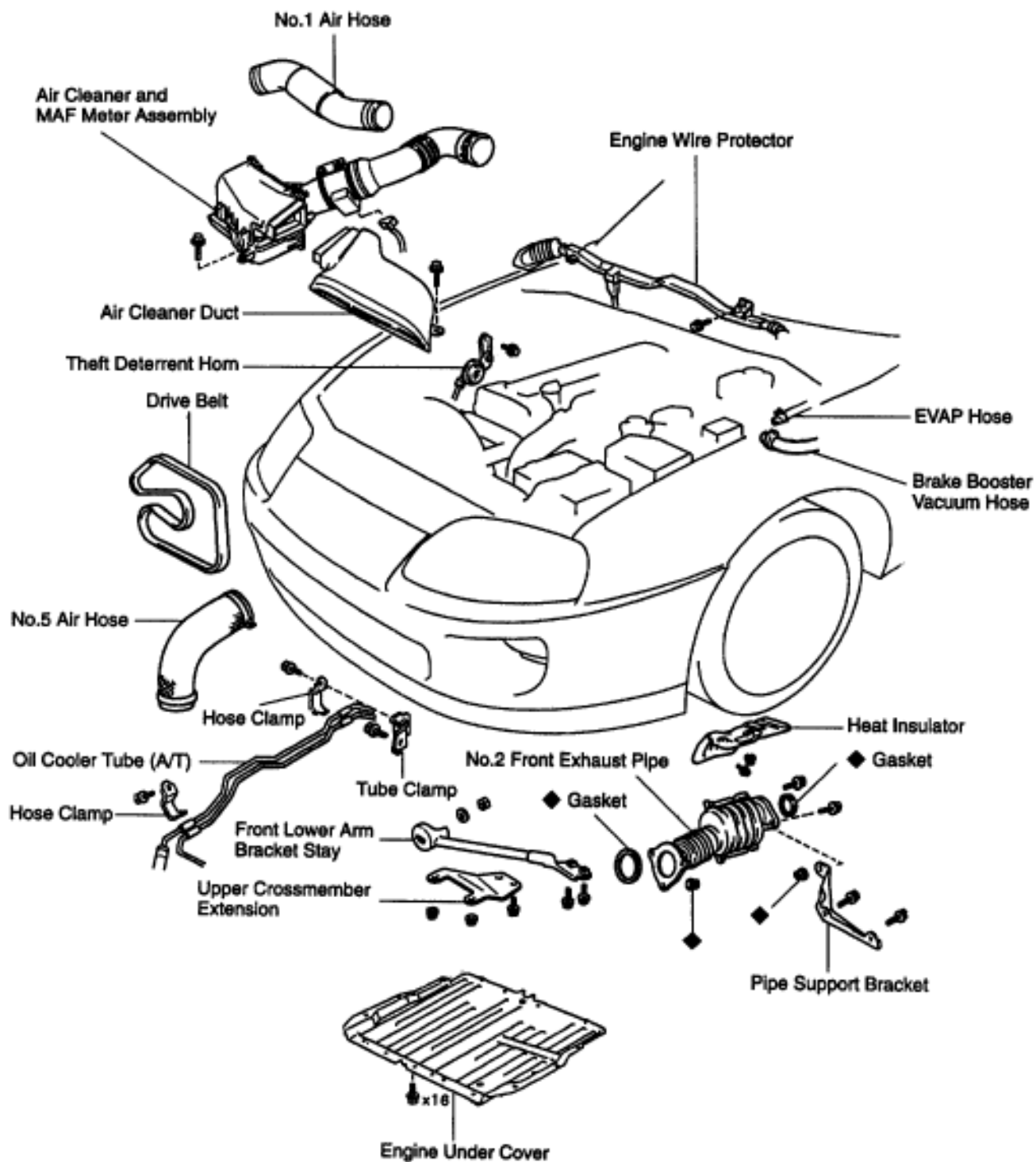

◆ Non-reusable part

P12614

2JZ-GTE

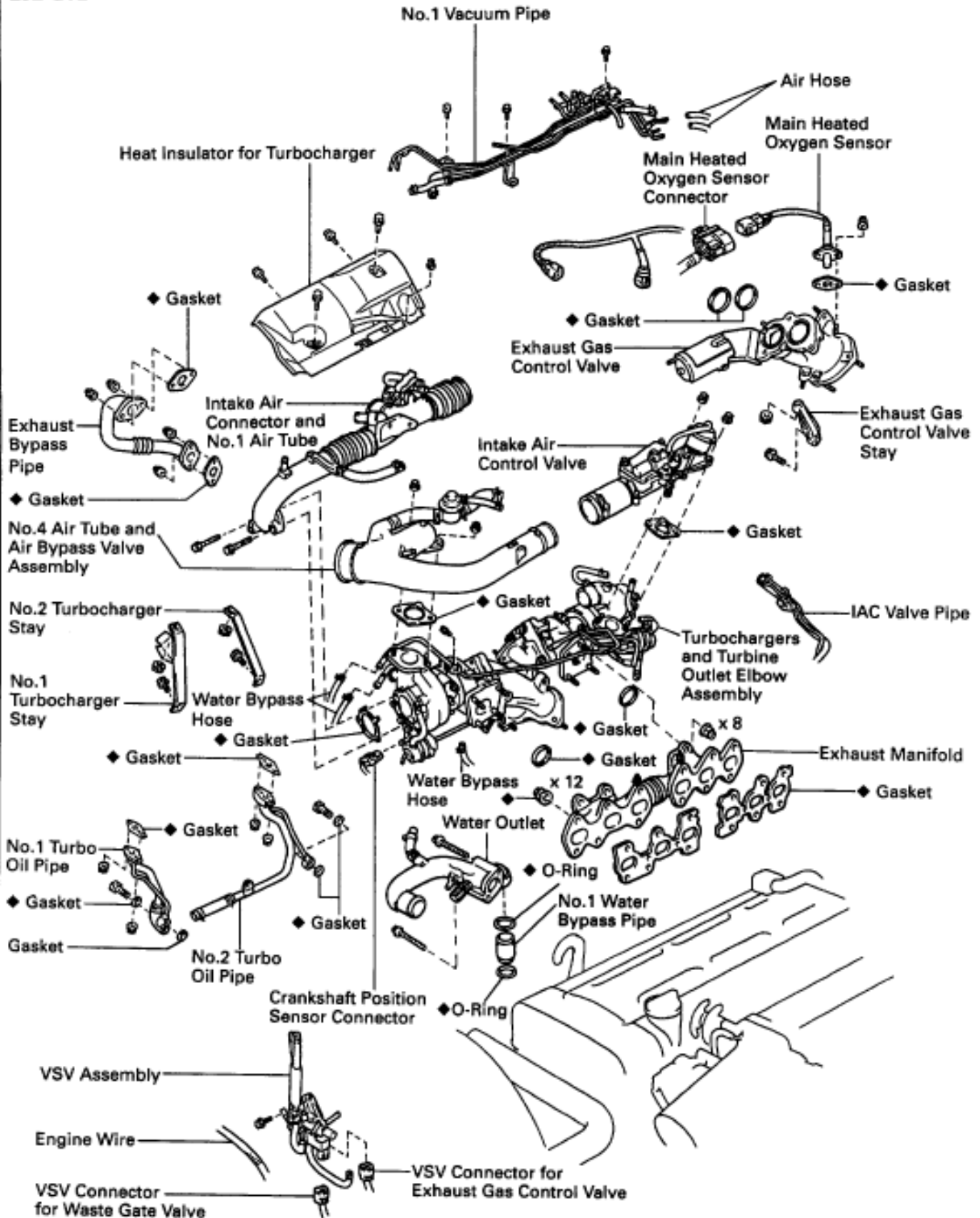

◆ Non-reusable part

2JZ-GTE

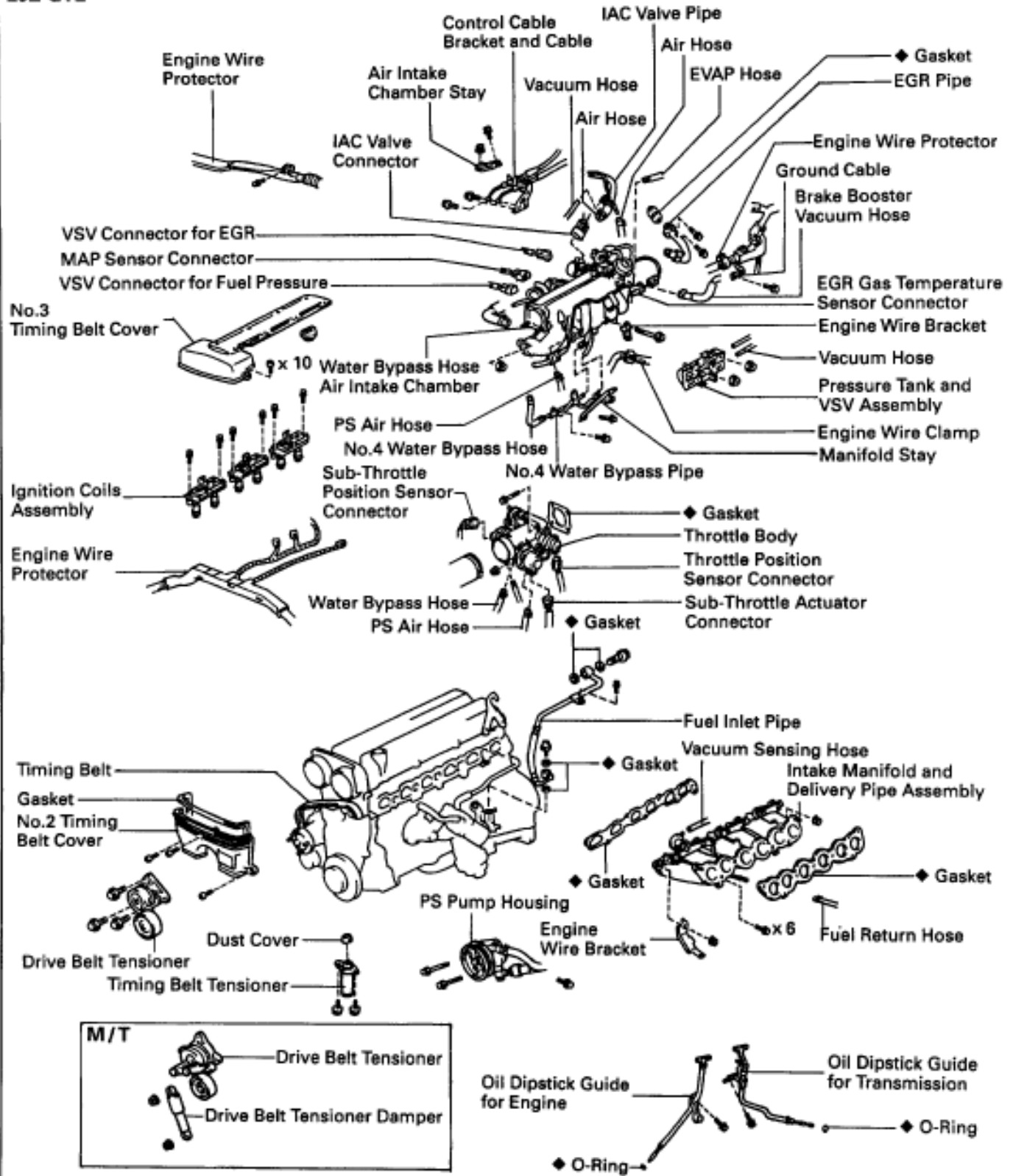

◆ Non-reusable part

2JZ-GTE

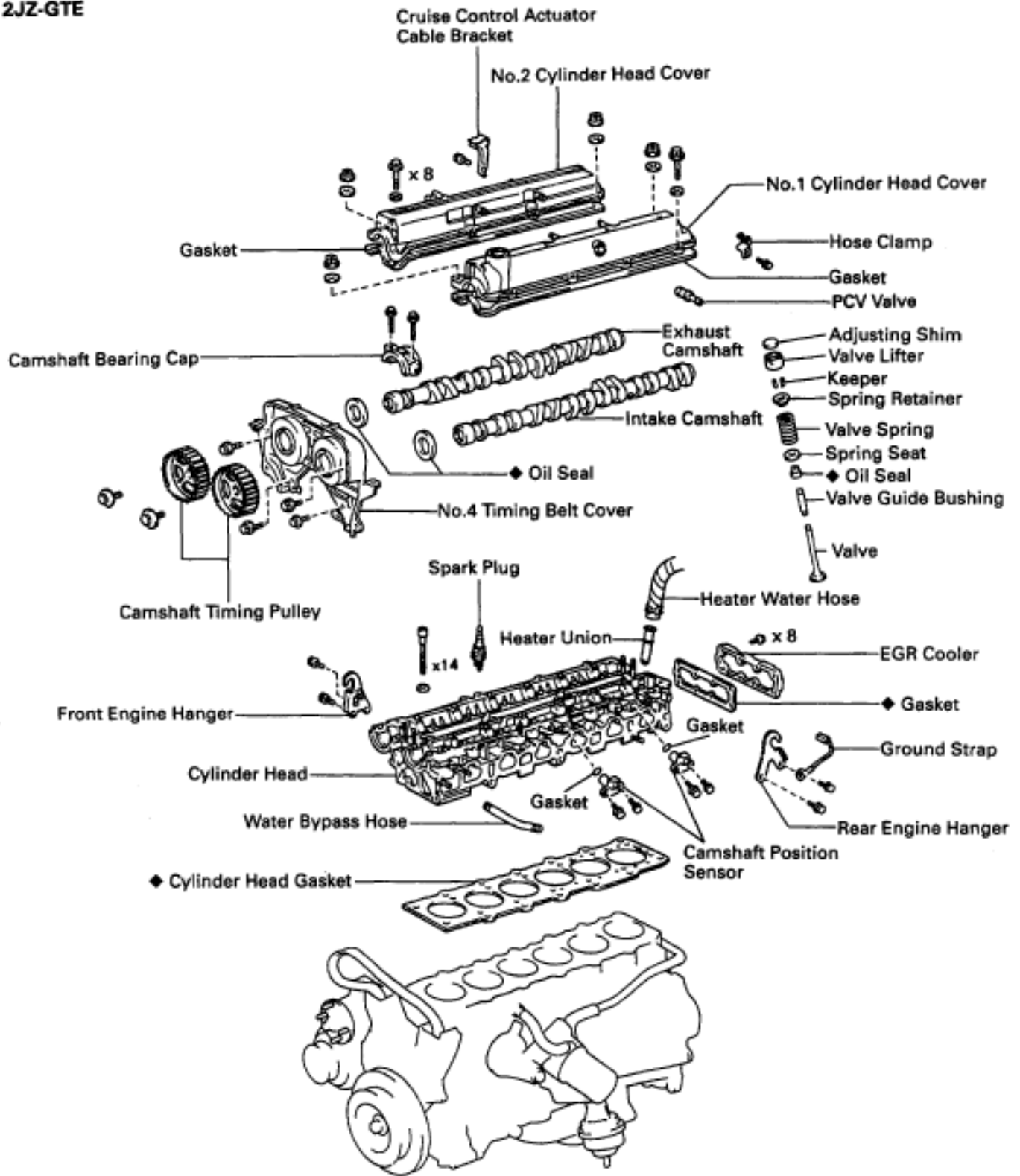

◆ Non-reusable part

CYLINDER HEAD REMOVAL (2JZ-GE)

1. REMOVE ENGINE UNDER COVER
2. DRAIN ENGINE COOLANT
3. REMOVE AIR CLEANER DUCT
4. REMOVE AIR CLEANER, VAF METER AND INTAKE AIR CONNECTOR PIPE ASSEMBLY
(See step 6 in engine removal in Engine Mechanical)

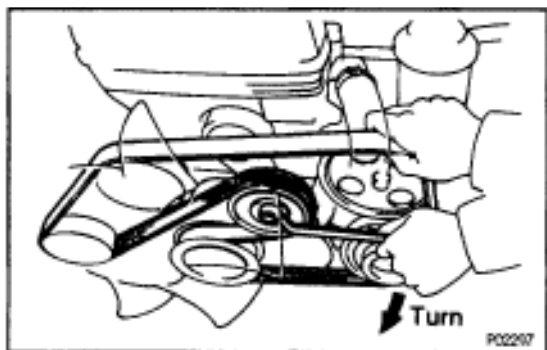

5. REMOVE DRIVE BELT
Loosen the drive belt tension by turning the drive belt tensioner clockwise, and remove the drive belt.
6. REMOVE NO.2 FRONT EXHAUST PIPE
(See step 22 in engine removal in Engine Mechanical)



7. REMOVE EXHAUST MANIFOLDS
 - (a) Except California:
Remove the 4 nuts and manifold heat insulator.
 - (b) Disconnect the 2 (main heated) oxygen sensor connectors.
 - (c) Remove the 4 nuts, exhaust manifold and gasket.
Remove the No.1 and No.2 exhaust manifolds.

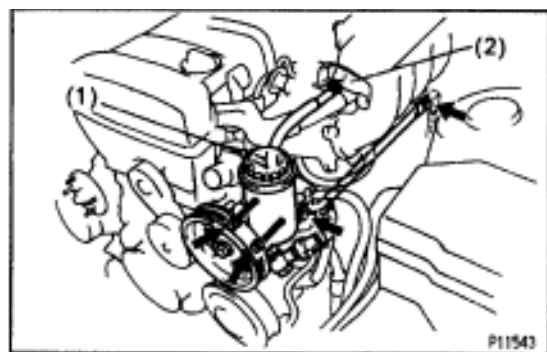

8. DISCONNECT PS PUMP WITHOUT DISCONNECTING HOSES
 - (a) Disconnect these hoses:
 - (1) Air hose from No.4 timing belt cover
 - (2) Air hose from air intake chamber
 - (b) Remove the 2 bolts, and disconnect the pump housing from the pump bracket.
HINT: Put aside the pump housing, and suspend it.
 - (c) Remove the 2 bolts and pump rear stay.

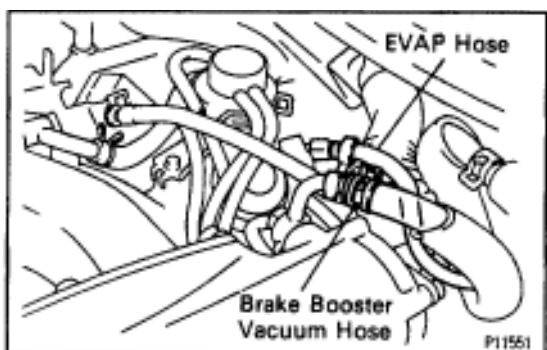

9. DISCONNECT BRAKE BOOSTER VACUUM HOSE
10. DISCONNECT EVAP HOSE
11. REMOVE THROTTLE BODY AND INTAKE AIR CONNECTOR ASSEMBLY
(See injector removal in SFI System)

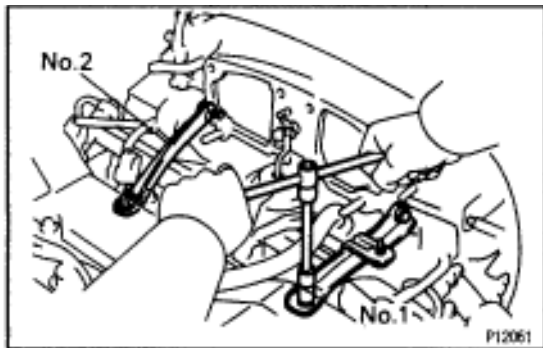
**12. REMOVE AIR INTAKE CHAMBER STAYS**

- (a) Remove the bolt, nut and No.1 stay.
- (b) Remove the bolt, nut and No.2 stay.

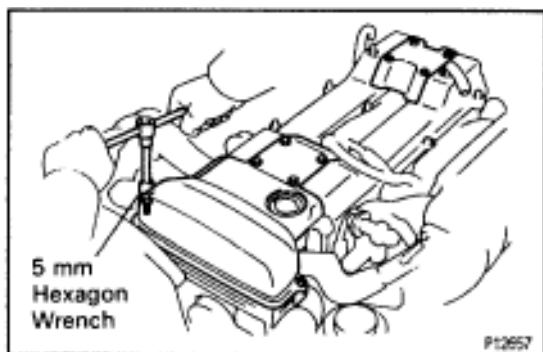
13. REMOVE NO.2 VACUUM PIPE AND VSV ASSEMBLY**14. REMOVE NO.3 TIMING BELT COVER**

- (a) Remove the oil filler cap.
- (b) Using a 5 mm hexagon wrench, remove the 6 bolts and timing belt cover.

15. REMOVE CYLINDER HEAD REAR COVER

Using a 5 mm hexagon wrench, remove the 4 bolts and cylinder head rear cover.

16. DISCONNECT HIGH-TENSION CORDS FROM CYLINDER HEAD COVERS

(See step 4 in high-tension cords and cord clamps removal in Ignition System)

17. REMOVE DISTRIBUTOR AND CORDS ASSEMBLY

(See steps 1 to 3 in distributor removal in Ignition System)

18. REMOVE SPARK PLUGS**19. REMOVE TIMING BELT FROM CAMSHAFT TIMING PULLEYS**

(See steps 5 to 8 in timing belt removal)

NOTICE:

- Support the timing belt, so that the meshing of the crankshaft timing pulley and timing belt does not shift.
- Be careful not to drop anything inside the timing belt cover.
- Do not allow the timing belt to come into contact with oil, water or dust.

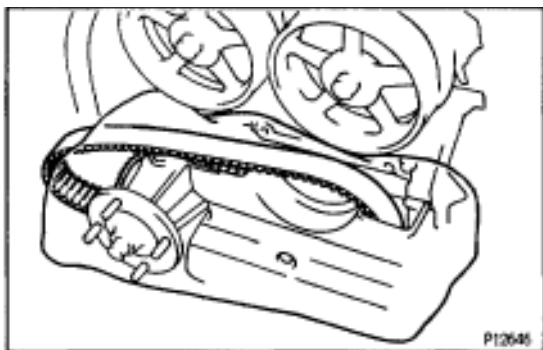
**20. REMOVE WATER BYPASS OUTLET AND NO.1 WATER BYPASS PIPE**

(See step 13 in water pump removal in Cooling System)

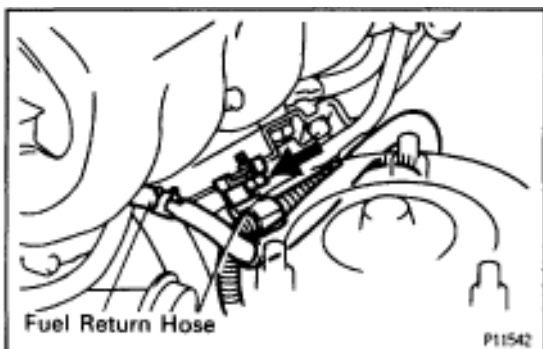
**21. DISCONNECT FUEL RETURN HOSE**

- (a) Disconnect the fuel return hose from the fuel return pipe. Plug the hose end.
- (b) Disconnect the fuel return hose from the oil dipstick guide.

22. REMOVE ENGINE WIRE BRACKET

Remove the bolt and bracket, disconnect the engine wire the intake manifold stay.

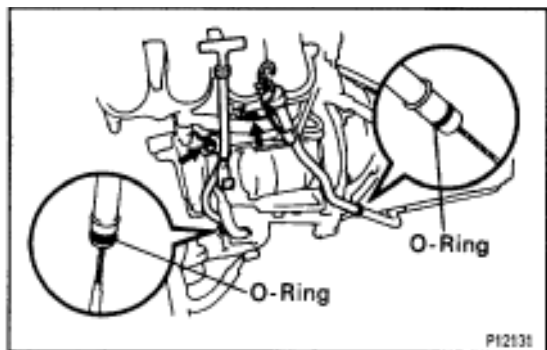

23. REMOVE OIL DIPSTICK GUIDES FOR ENGINE AND TRANSMISSION

- (a) Remove the 2 bolts.
- (b) Pull out the dipstick guide together with the dipstick.
- (c) Remove the O-ring from the dipstick guide.

24. REMOVE STARTER

(See starter removal in Starting System)

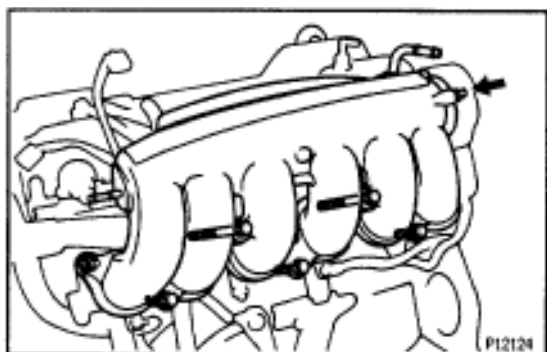

25. REMOVE AIR INTAKE CHAMBER

- (a) Except California:
Disconnect the vacuum sensing hose from the fuel pressure regulator.
- (b) Remove the bolt holding the engine wire protector to the the air intake chamber.
- (c) Remove the 5 bolts, nut, air intake chamber and gasket.

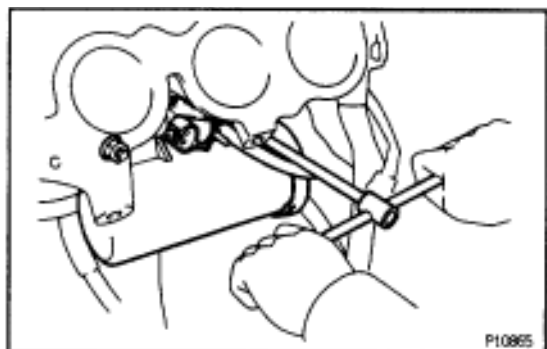

26. REMOVE VACUUM CONTROL VALVE SET

- (a) Disconnect the VSV connector.
- (b) Remove the 2 nuts and vacuum control valve set.

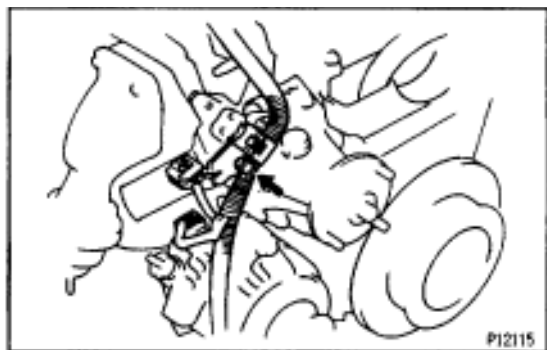

27. DISCONNECT ENGINE WIRE

- (a) Remove the bolt, and disconnect the engine wire bracket from the water pump.

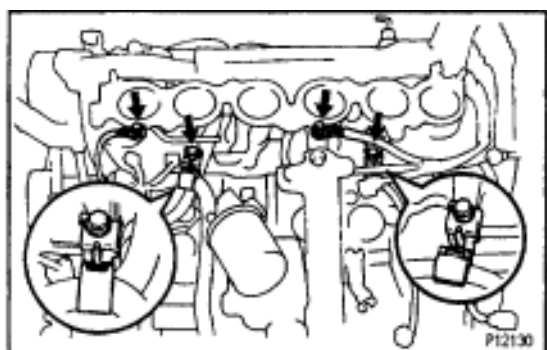

- (b) Remove the 2 bolts, and disconnect the 2 ground straps from the intake manifold.
- (c) Remove the 2 bolts, and disconnect the 2 wire clamps from the intake manifold.
- (d) Disconnect these connectors:
 - 6 injector connectors
 - ECT sensor connector
 - ECT sender gauge connector

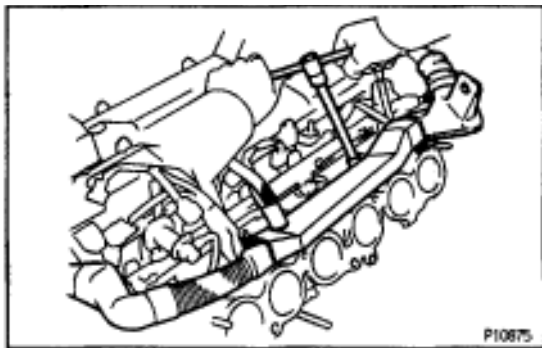

- (e) Remove the 3 nuts, and disconnect the engine wire protector from the intake manifold.

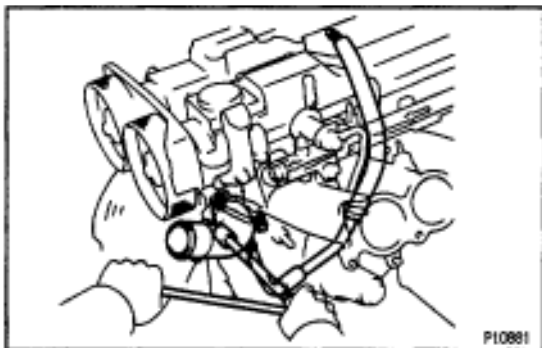

28. REMOVE WATER OUTLET AND NO.1 BYPASS HOSE ASSEMBLY

Remove the 2 nuts, bolt and water outlet.

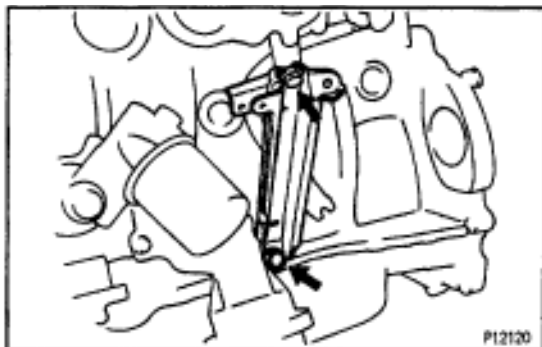

29. REMOVE INTAKE MANIFOLD STAY

Remove the 2 bolts and manifold stay.

30. REMOVE FUEL PRESSURE PULSATION DAMPER (See step 2 in fuel pressure pulsation damper in SFI System)

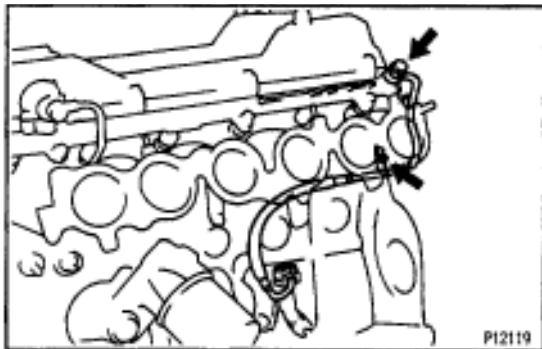

31. REMOVE FUEL INLET PIPE

- (a) Remove the clamp bolt from the intake manifold.
 (b) Remove the union bolt and 2 gaskets, and disconnect the fuel inlet pipe.

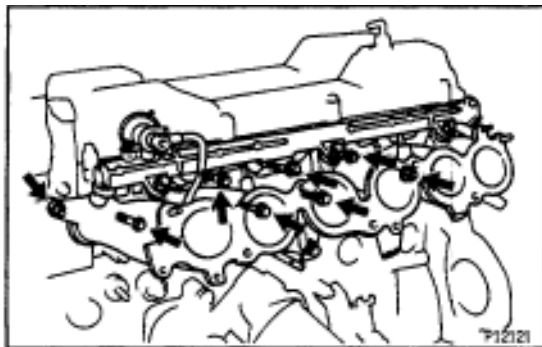

32. REMOVE INTAKE MANIFOLD AND DELIVERY PIPE ASSEMBLY

Remove the 6 bolts, 2 nuts, the intake manifold, delivery pipe assembly and gasket.

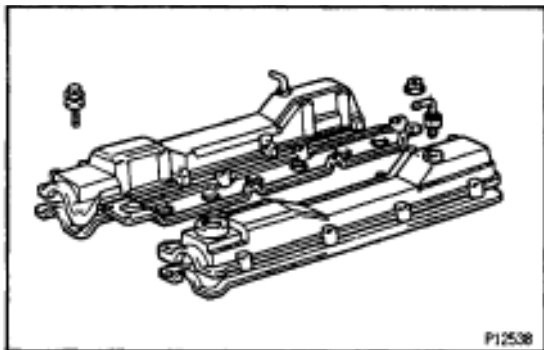

33. REMOVE NO.3, NO.1 AND NO.2 CYLINDER HEAD COVERS

- (a) Remove the PCV valve.
- (b) Remove the 4 bolts, 4 nuts and No.3 cylinder head cover.
- (c) Remove the 4 bolts, No.1 cylinder head cover and gasket.
- (d) Remove the 4 bolts, No.2 cylinder head cover and gasket.

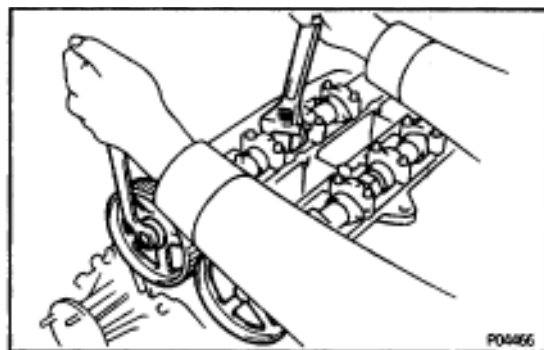

34. REMOVE CAMSHAFT TIMING PULLEYS

Hold the hexagon portion of the camshaft with a wrench, and remove the pulley mounting bolt and camshaft pulley.

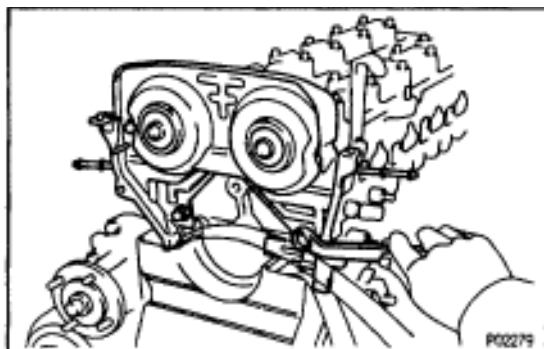

35. REMOVE NO.4 TIMING BELT COVER

Remove the 4 bolts and timing belt cover.

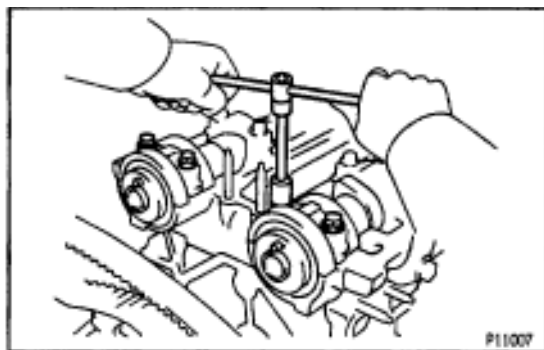

36. REMOVE CAMSHAFTS

- (a) Uniformly loosen and remove the 4 No.1 bearing cap bolts.

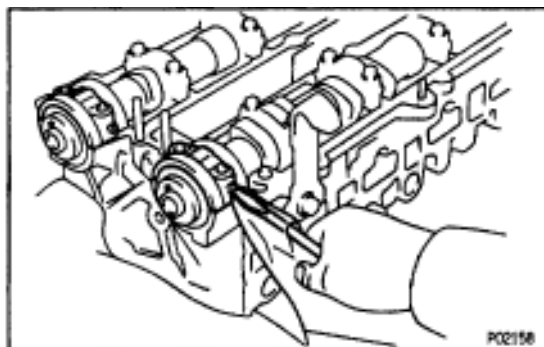

- (b) Using a screwdriver, pry out the 2 No.1 camshaft bearing caps and oil seals.

NOTICE: Be careful not to damage the cap. Tape the screwdriver tip.

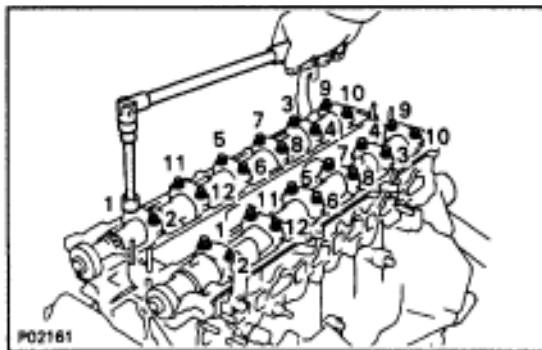

- (c) Uniformly loosen and remove the 12 bearing cap bolts, in several passes, in the sequence shown, and remove the 6 bearing caps and camshaft.
- (d) Remove the intake and exhaust camshafts.

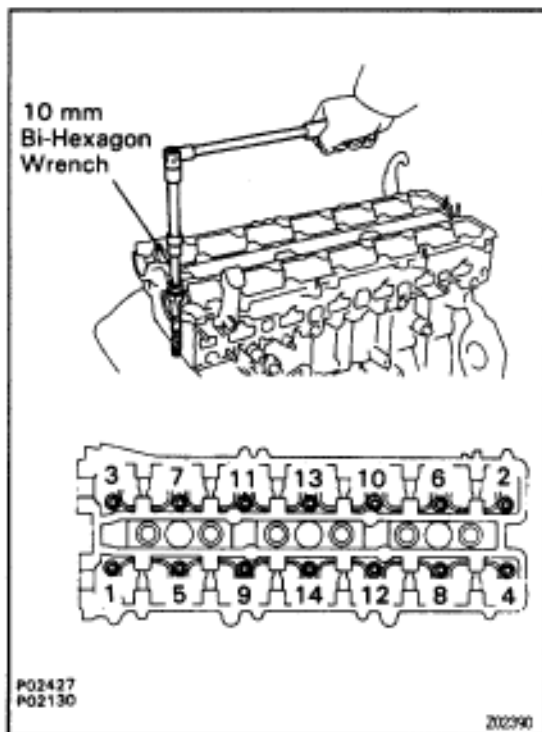

37. REMOVE CYLINDER HEAD

- (a) Using a 10 mm bi-hexagon wrench, uniformly loosen and remove the 14 cylinder head bolts, in several passes, in the sequence shown.

NOTICE: Cylinder head warpage or cracking could result from removing in incorrect order.

- (b) Remove the 14 plate washers.

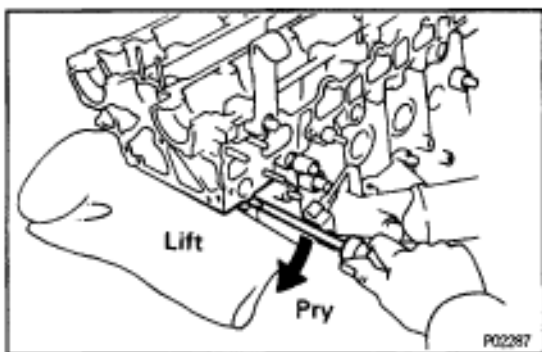

- (c) Lift the cylinder head from the dowels on the cylinder block.
 - (d) Place the head on wooden blocks on a bench.
- If the cylinder head is difficult to lift off, pry with a screwdriver between the cylinder head and block projection.

NOTICE: Be careful not to damage the contact surfaces of the cylinder head and cylinder block.

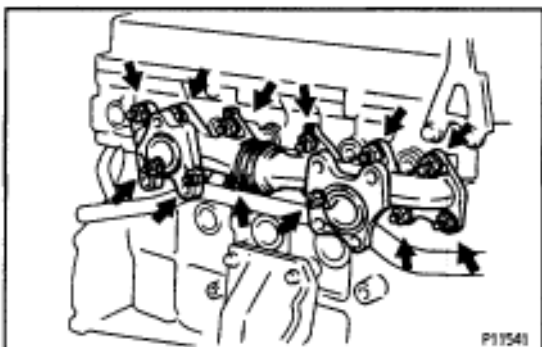

CYLINDER HEAD REMOVAL (2JZ-GTE)

1. REMOVE TURBOCHARGER
(See turbocharger removal in Turbocharger System)
2. REMOVE EXHAUST MANIFOLD
Remove the 12 nuts, exhaust manifold and 2 gaskets.
3. M/T:
REMOVE DRIVE BELT TENSIONER DAMPER
(See step 2 in timing belt removal)

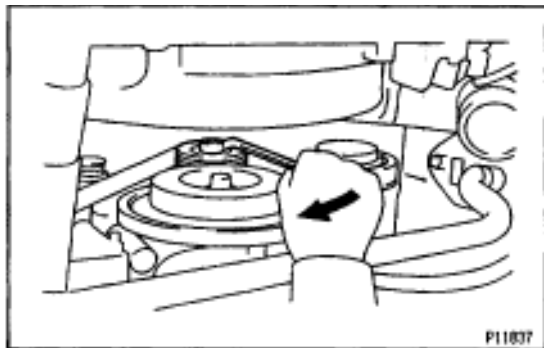

4. REMOVE DRIVE BELT

Loosen the drive belt tension by turning the drive belt tensioner clockwise, and remove the drive belt.



5. REMOVE WATER OUTLET AND NO.1 WATER BYPASS PIPE

- (a) Disconnect the upper radiator hose from the water outlet.
- (b) Disconnect the ECT sensor and sender gauge connectors.
- (c) Remove the 2 bolts, water outlet and gasket.

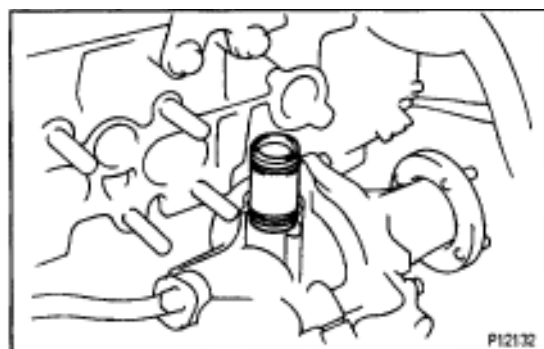

- (d) Remove the No.1 water bypass pipe and 2 O-rings.

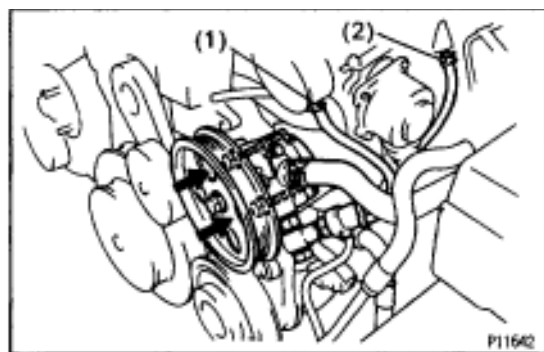

6. DISCONNECT PS PUMP WITHOUT DISCONNECTING HOSES

- (a) Disconnect these hoses:
 - (1) Air hose from throttle body
 - (2) Air hose from air intake chamber
- (b) Remove the 2 bolts, and disconnect the pump housing from the pump bracket.
HINT: Put aside the pump housing, and suspend it securely.

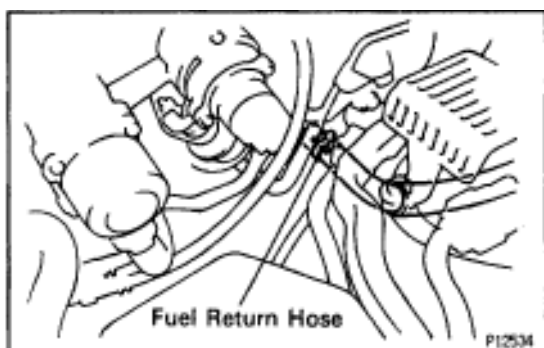

7. DISCONNECT FUEL RETURN HOSE

Disconnect the fuel return hose from the fuel return pipe. Plug the hose end.

8. REMOVE AIR INTAKE CHAMBER ASSEMBLY (See injector removal in SFI System)

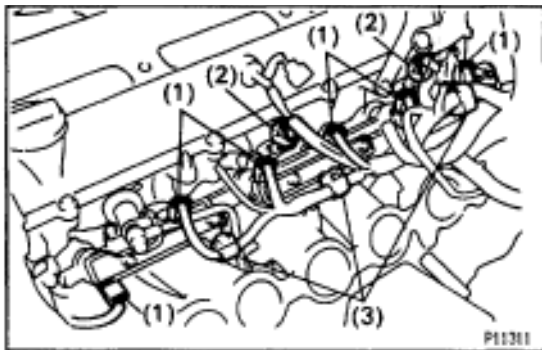

9. DISCONNECT ENGINE WIRE

- (a) Disconnect these connectors and clamps:
- (1) 6 injectors connectors
 - (2) 2 camshaft position sensor connectors
 - (3) 3 engine wire clamps from injector holders

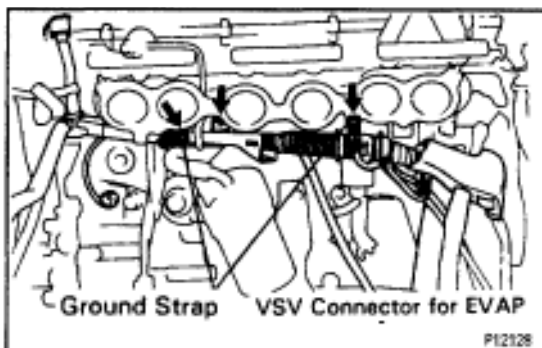

- (4) VSV connector for EVAP
- (b) Remove the 2 bolts, and disconnect the 2 ground straps from the intake manifold.
- (c) Remove the nut, and disconnect the engine wire protector from the intake manifold.

10. REMOVE STARTER

(See starter removal in Starting System)

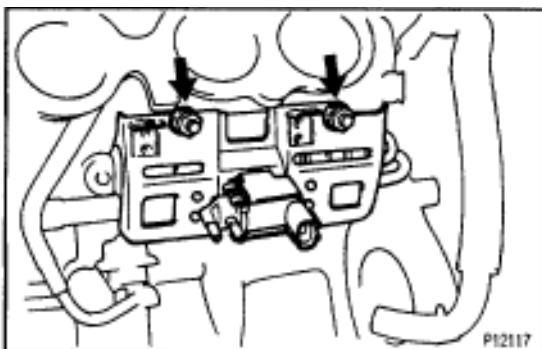

11. REMOVE PRESSURE TANK AND VSV ASSEMBLY

- (a) Disconnect the 2 vacuum hoses from the pressure tank.
 (b) Remove the 2 nuts and pressure tank and VSV assembly.

12. REMOVE FUEL PRESSURE PULSATION DAMPER

(See step 2 in fuel pressure pulsation damper in SFI System)

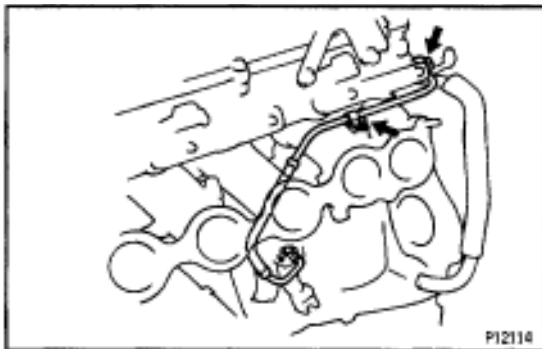

13. REMOVE FUEL INLET PIPE

Remove the union bolt, 2 gaskets, clamp bolt and fuel inlet pipe.

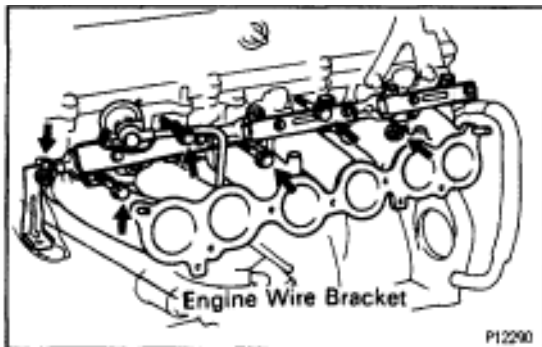

14. REMOVE INTAKE MANIFOLD AND DELIVERY PIPE ASSEMBLY

Remove the 4 bolts, 2 nuts, engine wire bracket, the intake manifold, delivery pipe assembly and gasket.

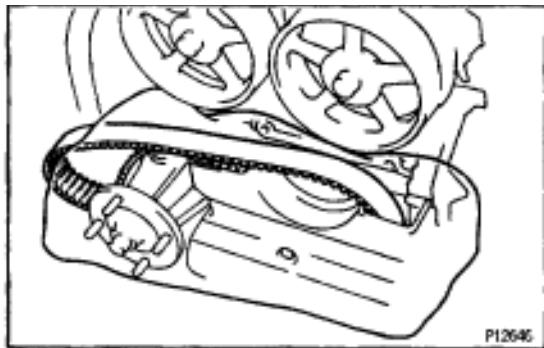

15. REMOVE TIMING BELT FROM CAMSHAFT TIMING PULLEYS

(See steps 5 to 8 in timing belt removal)

NOTICE:

- Support the timing belt, so that the meshing of the crankshaft timing pulley and timing belt does not shift.
- Be careful not to drop anything inside the timing belt cover.
- Do not allow the timing belt to come into contact with oil, water or dust.

16. REMOVE IGNITION COILS ASSEMBLIES

(See steps 2 to 5 in ignition coils removal in Ignition System)

17. REMOVE SPARK PLUGS

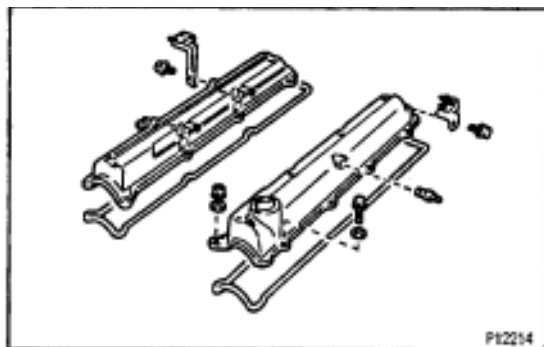

18. REMOVE NO.1 AND NO.2 CYLINDER HEAD COVERS

- Remove the 2 bolts, cruise control actuator cable bracket and IAC valve pipe clamp.
- Remove the PCV valve.
- Remove the 6 bolts, 2 nuts, 8 seal washers and No.1 cylinder head cover and gasket.
- Remove the 6 bolts, 2 nuts, 8 seal washers and No.2 cylinder head cover and gasket.

19. REMOVE CAMSHAFT TIMING PULLEYS

(See step 34 cylinder head removal (2JZ-GE))

20. REMOVE NO.4 TIMING BELT COVER

(See step 35 cylinder head removal (2JZ-GE))

21. REMOVE CAMSHAFTS

(See step 36 cylinder head removal (2JZ-GE))

22. REMOVE CYLINDER HEAD

(See step 37 cylinder head removal (2JZ-GE))

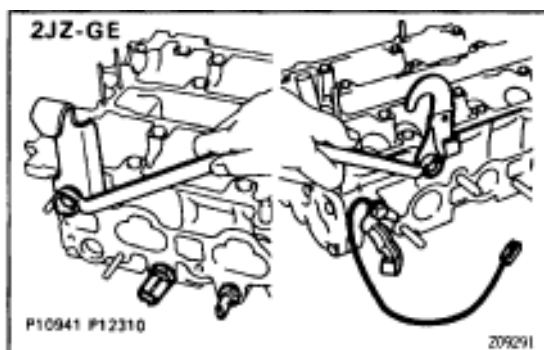

CYLINDER HEAD DISASSEMBLY

- 2JZ-GE:
REMOVE ENGINE HANGERS
- 2JZ-GE:
REMOVE ECT SENSOR AND SENDER GAUGE
- 2JZ-GE:
REMOVE THROTTLE CABLE BRACKET AND GROUND STRAP

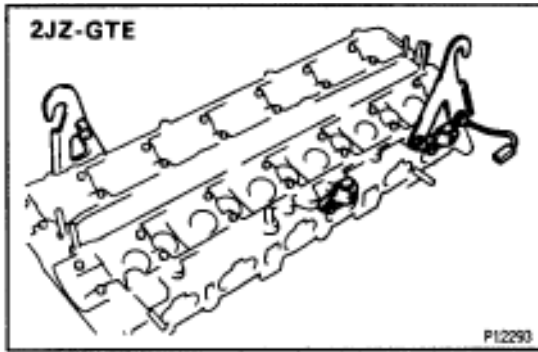

4. **2JZ-GTE:**
REMOVE ENGINE HANGERS AND GROUND STRAP
5. **2JZ-GTE:**
REMOVE CAMSHAFT POSITION SENSORS
6. **REMOVE EGR COOLER**

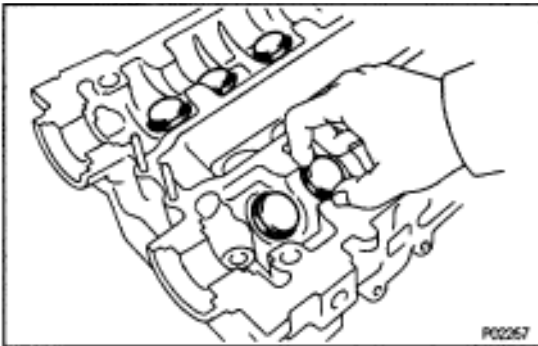

7. **REMOVE VALVE LIFTERS AND SHIMS**
HINT: Store the valve lifters and shims in correct order.

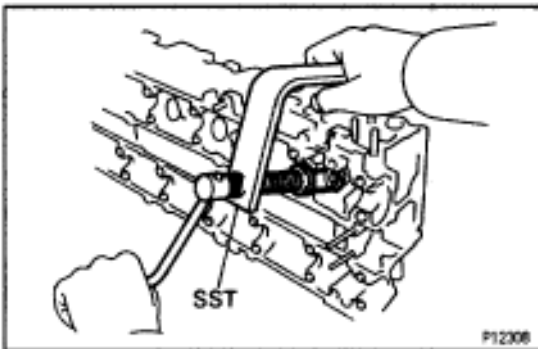

8. **REMOVE VALVES**
 - (a) Using SST, compress the valve spring and remove the 2 keepers.
SST 09202-70010
 - (b) Remove the spring retainer, valve spring, valve and spring seat.
HINT: Store the valves, valve springs, spring seats and spring retainers in correct order.

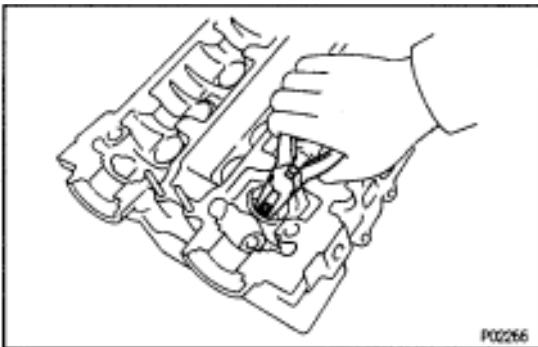

- (c) Using needle-nose pliers, remove the oil seal.

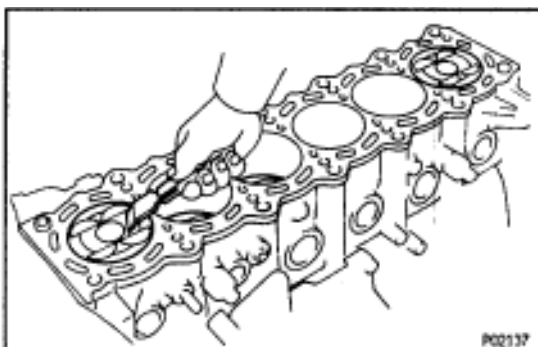

CYLINDER HEAD COMPONENTS INSPECTION AND REPAIR

1. **CLEAN TOP SURFACES OF PISTONS AND CYLINDER BLOCK**
 - (a) Turn the crankshaft, and bring each piston to top dead center (TDC). Using a gasket scraper, remove all the carbon from the piston top surface.

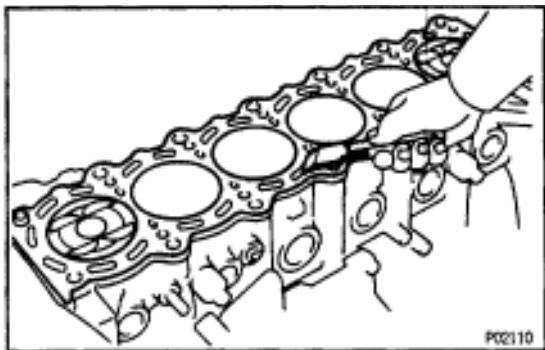

- (b) Using a gasket scraper, remove all the gasket material from the top surface of the cylinder block.
- (c) Using compressed air, blow carbon and oil from the bolt holes.

CAUTION: Protect your eyes when using high pressure compressed air.

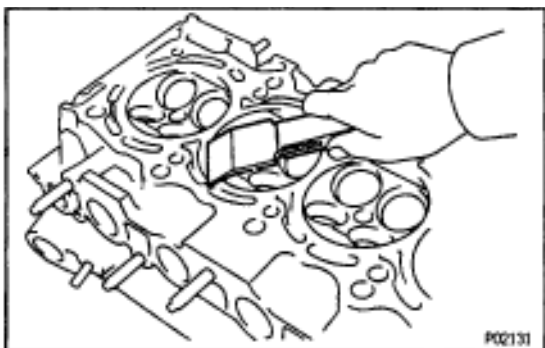

2. CLEAN CYLINDER HEAD

A. Remove gasket material

Using a gasket scraper, remove all the gasket material from the cylinder block surface.

NOTICE: Be careful not to scratch the cylinder block contact surface.

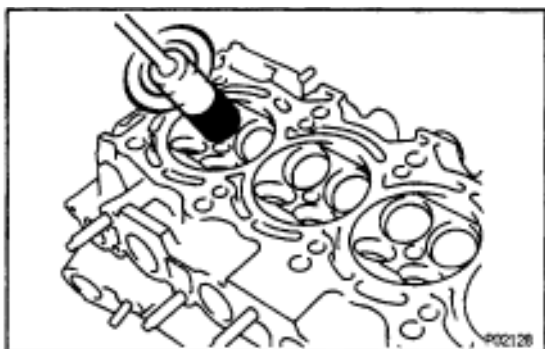

B. Clean combustion chambers

Using a wire brush, remove all the carbon from the combustion chambers.

NOTICE: Be careful not to scratch the cylinder block contact surface.

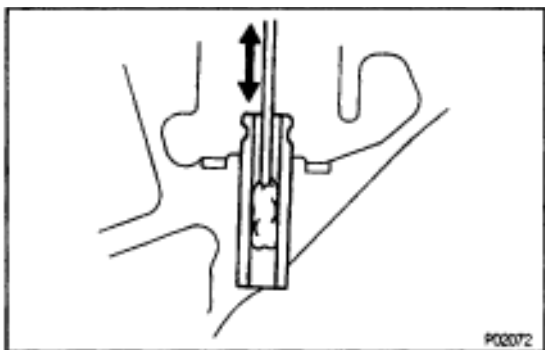

C. Clean valve guide bushings

Using a valve guide bushing brush and solvent, clean all the guide bushings.

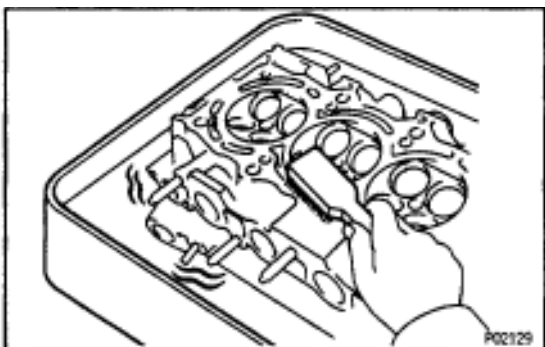

D. Clean cylinder head

Using a soft brush and solvent, thoroughly clean the cylinder head.

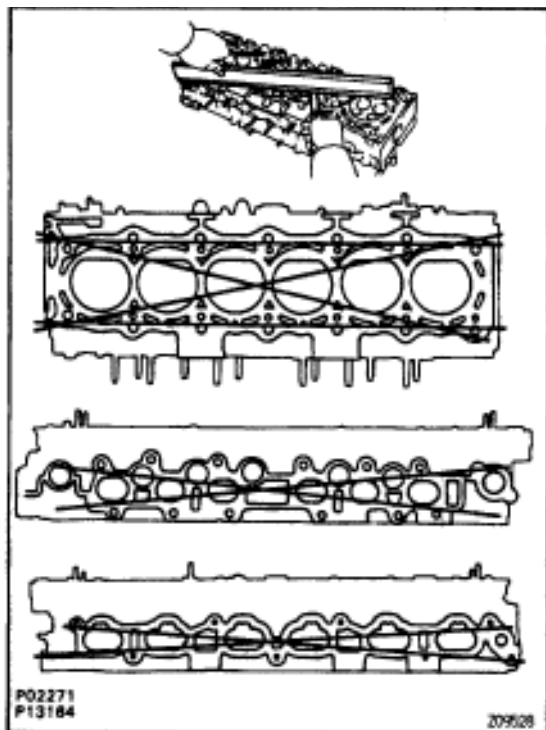

3. INSPECT CYLINDER HEAD

A. Inspect for flatness

Using precision straight edge and feeler gauge, measure the surfaces contacting the cylinder block, intake and exhaust manifolds for warpage.

Maximum warpage:

0.10 mm (0.0039 in.)

If warpage is greater than maximum, replace the cylinder head.

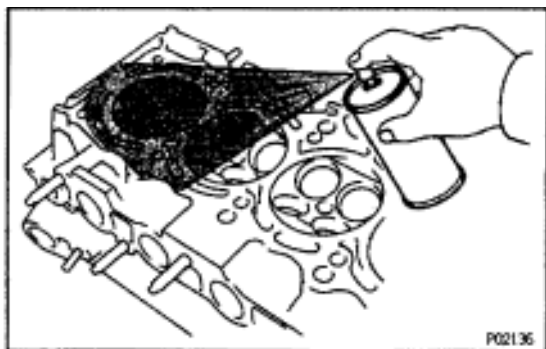

B. Inspect for cracks

Using a dye penetrant, check the combustion chamber, intake ports, exhaust ports and cylinder block surface for cracks.

If cracked, replace the cylinder head.

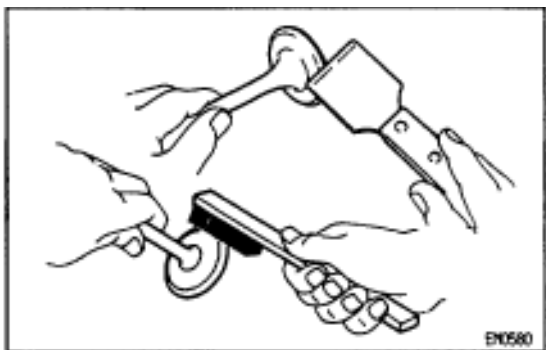

4. CLEAN VALVES

- Using a gasket scraper, chip off any carbon from the valve head.
- Using a wire brush, thoroughly clean the valve.

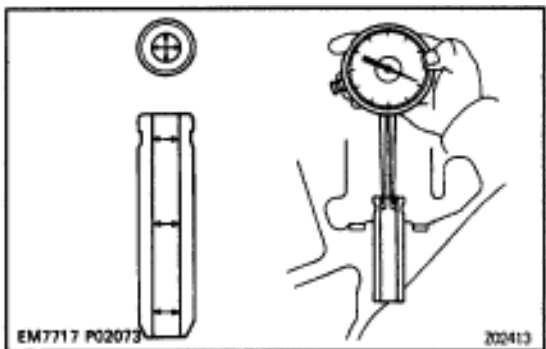

5. INSPECT VALVE STEMS AND GUIDE BUSHINGS

- Using a caliper gauge, measure the inside diameter of the guide bushing.

Bushing inside diameter:

6.010–6.030 mm (0.2366–0.2374 in.)

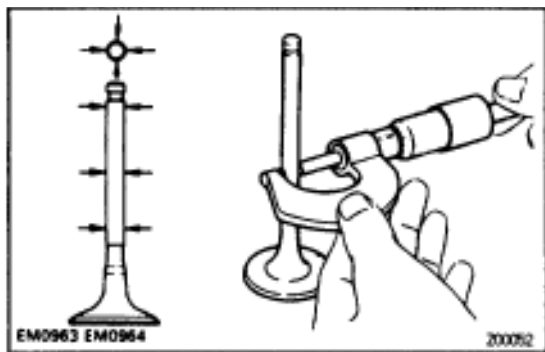

(b) Using a micrometer, measure the diameter of the valve stem.

Valve stem diameter:

Intake

5.970–5.985 mm (0.2350–0.2356 in.)

Exhaust

5.965–5.980 mm (0.2348–0.2354 in.)

(c) Subtract the valve stem diameter measurement from the guide bushing inside diameter measurement.

Standard oil clearance:

Intake

.025–0.060 mm (0.0010–0.0024 in.)

Exhaust

.030–0.065 mm (0.0012–0.0026 in.)

Maximum oil clearance:

Intake

.08 mm (0.0031 in.)

Exhaust

.10 mm (0.0039 in.)

If the clearance is greater than maximum, replace the valve and guide bushing.

6. IF NECESSARY, REPLACE VALVE GUIDE BUSHINGS

(a) Using SST and a hammer, tap out the guide bushing.

SST 09201–10000 (09201–01060).

09608–30022 (09608–05010)

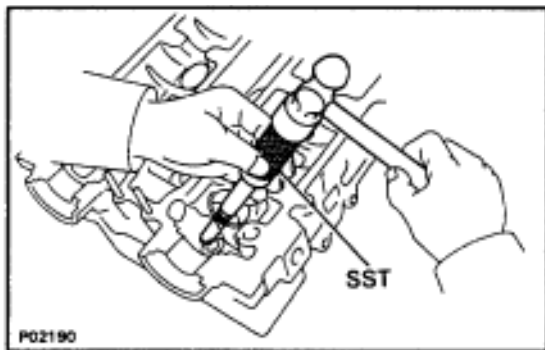

(b) Using a caliper gauge, measure the bushing bore diameter of the cylinder head.

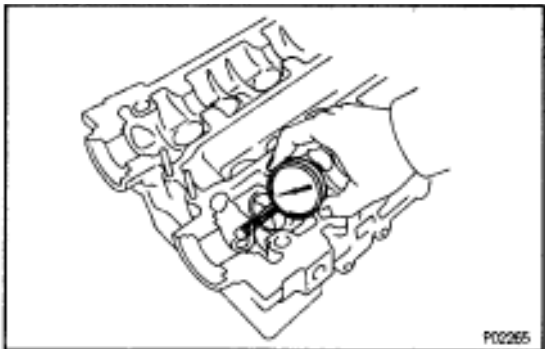

Both intake and exhaust

Bushing bore diameter mm (in.)	Bushing size
10.985–11.006 mm (0.4325–0.4333 in.)	Use STD
11.035–11.056 mm (0.4344–0.4353 in.)	Use O/S 0.05

Select a new guide bushing (STD or O/S 0.05).

If the bushing bore diameter of the cylinder head is greater than 11.006 mm (0.4333 in.), machine the bushing bore to the following dimension:

11.035–11.056 mm (0.4344–0.4353 in.)

If the bushing bore diameter of the cylinder head is greater than 11.056 mm (0.4353 in.), replace the cylinder head.

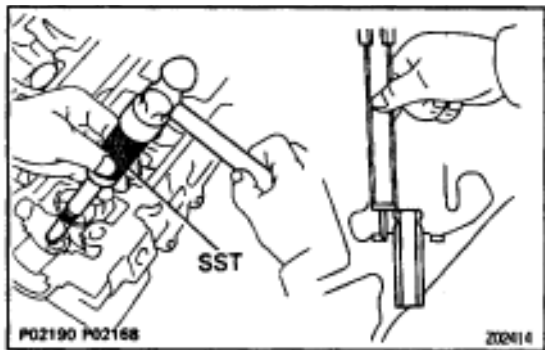

- (d) Using SST and a hammer, tap in a new guide bushing to the specified protrusion height.

SST 09201-10000 (09201-01060), 09608-30022
(09608-05010)

Protrusion height:

Intake

12.3–12.7 mm (0.484–0.500 in.)

Exhaust

11.4–11.8 mm (0.449–0.465 in.)

HINT: Different bushings are used for the intake and exhaust.

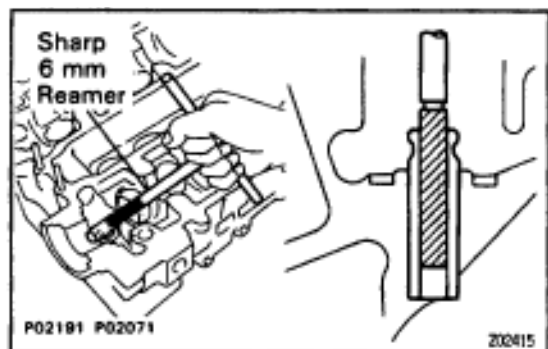
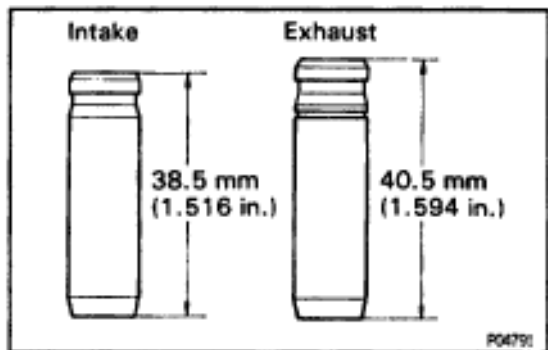

- (e) Using a sharp 6 mm reamer, ream the guide bushing to obtain the standard specified clearance (See step 6) between the guide bushing and valve stem.

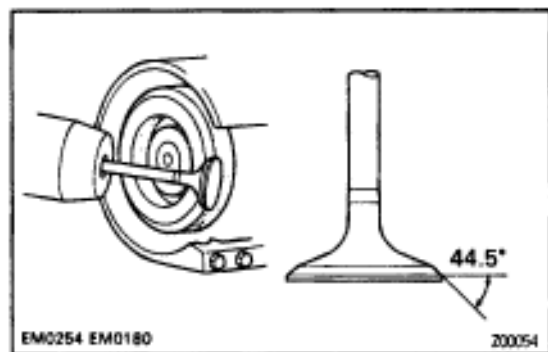

7. INSPECT AND GRIND VALVES

- (a) Grind the valve enough to remove pits and carbon.

- (b) Check that the valve is ground to the correct valve face angle.

Valve face angle:

44.5°

- (c) Check the valve head margin thickness.

Standard margin thickness:

0.8–1.2 mm (0.031–0.047 in.)

Minimum margin thickness:

0.5 mm (0.020 in.)

If the margin thickness is less than minimum, replace the valve.

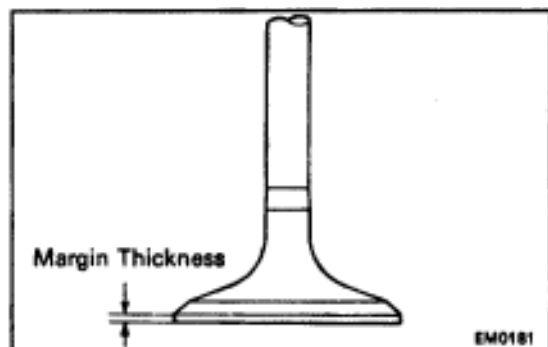

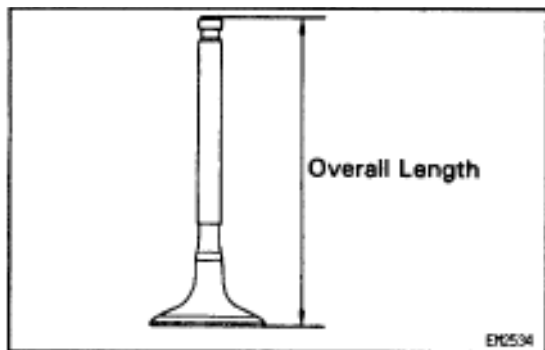

- (d) Check the valve overall length.
Standard overall length:
Intake
 98.29–98.79 mm (3.8697–3.8894 in.)
Exhaust
 98.84–99.34 mm (3.8913–3.9110 in.)

Minimum overall length:

- Intake**
 98.19 mm (3.8657 in.)
Exhaust
 98.74 mm (3.8874 in.)

If the overall length is less than minimum, replace the valve.

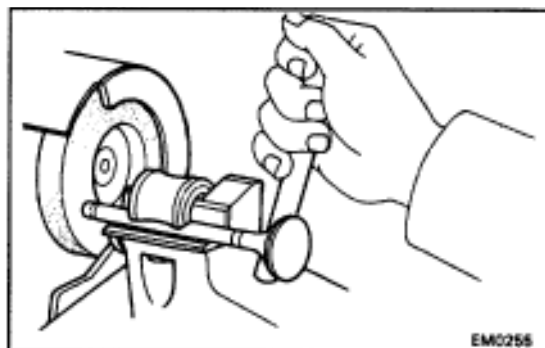

- (e) Check the surface of the valve stem tip for wear.
 If the valve stem tip is worn, resurface the tip with a grinder or replace the valve.
NOTICE: Do not grind off more than the minimum overall length.

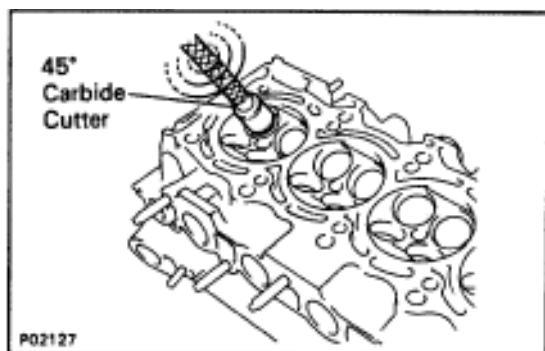

8. INSPECT AND CLEAN VALVE SEATS

- (a) Using a 45° carbide cutter, resurface the valve seats.
 Remove only enough metal to clean the seats.

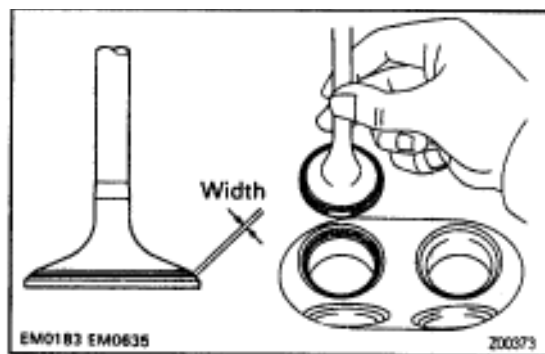

- (b) Check the valve seating position.
 Apply a thin coat of prussian blue (or white lead) to the valve face. Lightly press the valve against the seat. Do not rotate the valve.

- (c) Check the valve face and seat for the following:
- If blue appears 360° around the face, the valve is concentric. If not, replace the valve.
 - If blue appears 360° around the valve seat, the guide and face are concentric. If not, resurface the seat.

- Check that the seat contact is in the middle of the valve face with the following width:

Intake
 1.0–1.4 mm (0.039–0.055 in.)

Exhaust
 1.2–1.6 mm (0.047–0.063 in.)

If not, correct the valve seats as follows:

- If the seating is too high on the valve face, use 15° and 45° cutters to correct the seat.

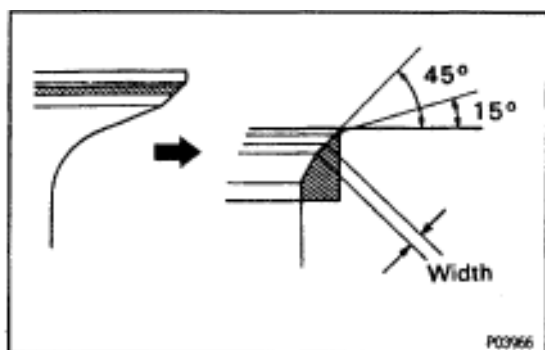

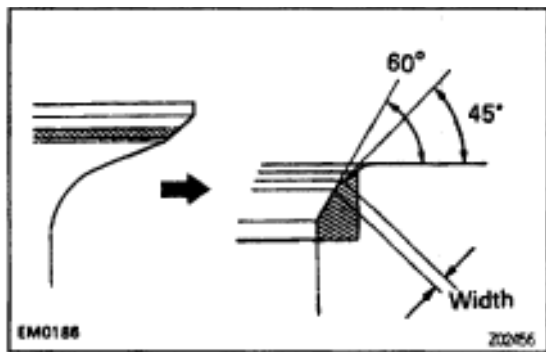

- If the seating is too low on the valve face, use 60° and 45° cutters to correct the seat.

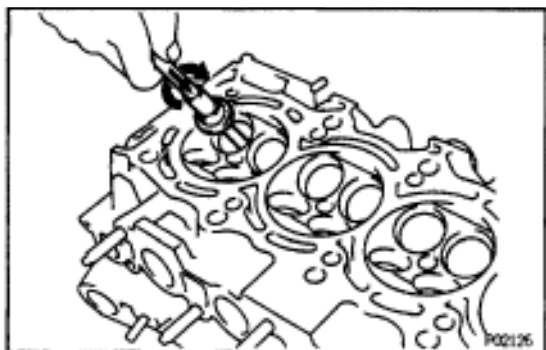

- Hand-lap the valve and valve seat with an abrasive compound.
- After hand-lapping, clean the valve and valve seat.

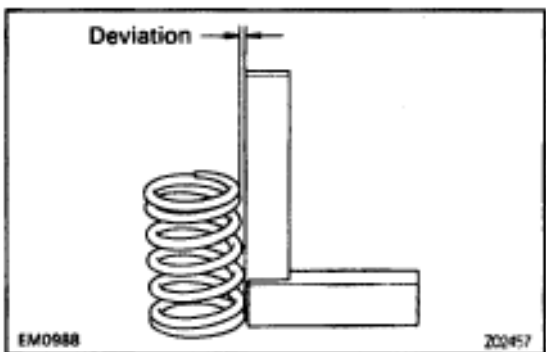

9. INSPECT VALVE SPRINGS

- Using a steel square, measure the deviation of the valve spring.

Maximum deviation:

2.0 mm (0.079 in.)

If deviation is greater than maximum, replace the valve spring.

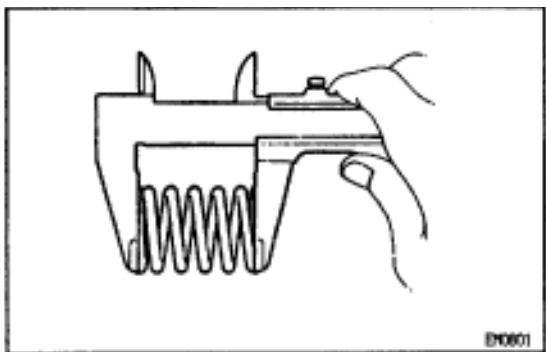

- Using vernier calipers, measure the free length of the valve spring.

Free length:

Blue painted mark

41.74 mm (1.6433 in.)

Yellow painted mark

41.70 mm (1.6417 in.)

If the free length is not as specified, replace the valve spring.

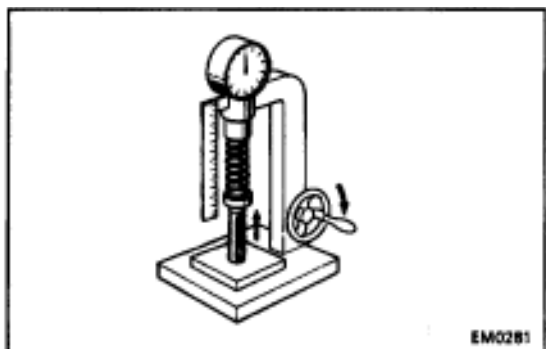

- Using a spring tester, measure the tension of the valve spring at the specified installed length.

Installed tension:

186–206 N (19.0–21.0 kgf, 42–46 lbf) at 34.5 mm (1.358 in.)

If the installed tension is not as specified, replace the valve spring.

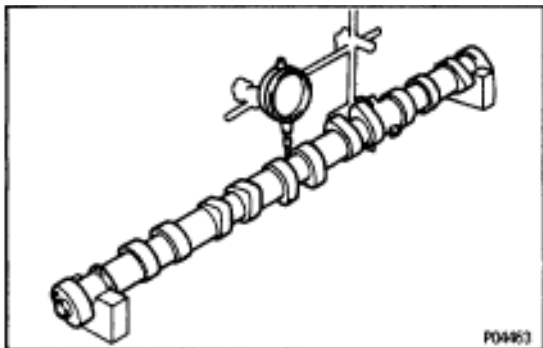

10. INSPECT CAMSHAFTS AND BEARINGS

A. Inspect camshaft for runout

- Place the camshaft on V-blocks.
- Using a dial indicator, measure the circle runout at the center journal.

Maximum circle runout:

0.08 mm (0.0031 in.)

If the circle runout is greater than maximum, replace the camshaft.

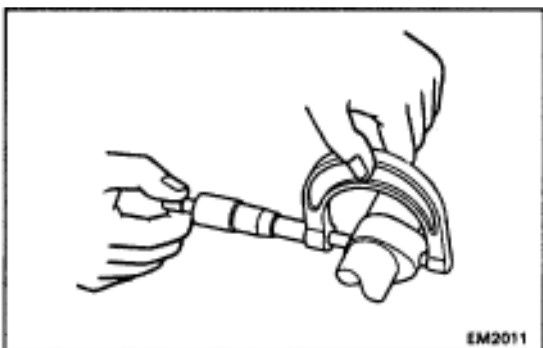

B. Inspect cam lobes

Using a micrometer, measure the cam lobe height.

Standard cam lobe height:

Intake

44.570–44.670 mm (1.7547–1.7587 in.)

Exhaust

44.770–44.870 mm (1.7626–1.7665 in.)

Maximum cam lobe height:

Intake

44.42 mm (1.7488 in.)

Exhaust

44.62 mm (1.7567 in.)

If the cam lobe height is less than minimum, replace the camshaft.

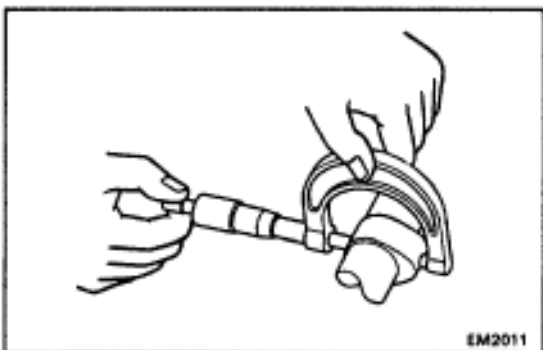

C. Inspect camshaft journals

Using a micrometer, measure the journal diameter.

Journal diameter:

28.949–28.965 mm (1.1397–1.1404 in.)

If the journal diameter is not as specified, check the oil clearance.

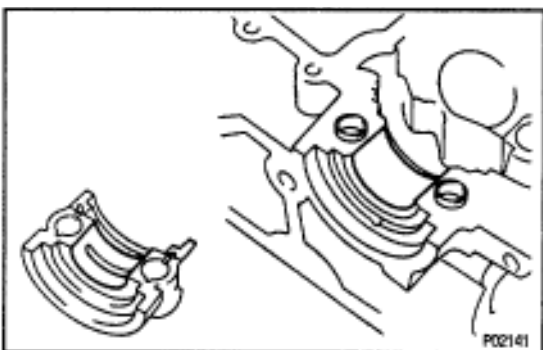

D. Inspect camshaft bearings

Check the bearings for flaking and scoring.

If the bearings are damaged, replace the bearing caps and cylinder head as a set.

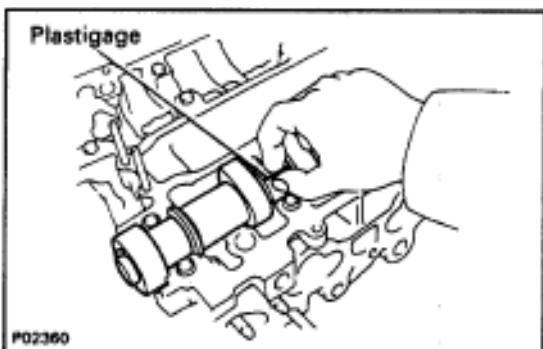

E. Inspect camshaft journal oil clearance

- Clean the bearing caps and camshaft journals.
- Place the camshafts on the cylinder head.
- Lay a strip of Plastigage across each of the camshaft journals.

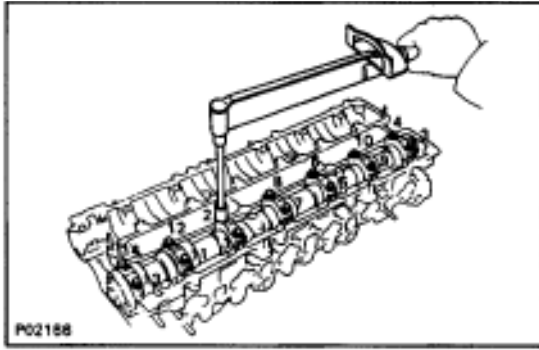

- (d) Install the bearing caps.
(See step 2 in cylinder head installation (2JZ-GE))
Torque: 20 N·m (200 kgf·cm, 14 ft·lbf)
NOTICE: Do not turn the camshaft.
- (e) Remove the bearing caps.

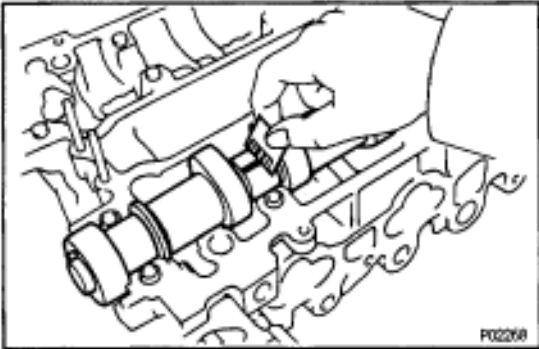

- (f) Measure the Plastigage at its widest point.
Standard oil clearance:
0.035–0.072 mm (0.0014–0.0028 in.)
Maximum oil clearance:
0.10 mm (0.0039 in.)
If the oil clearance is greater than maximum, replace the camshaft. If necessary, replace the bearing caps and cylinder head as a set.
- (g) Completely remove the Plastigage.

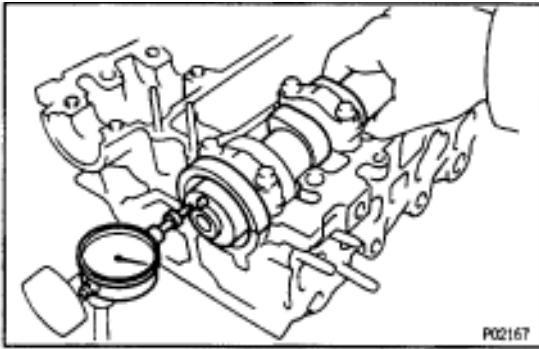

F. Inspect camshaft thrust clearance

- (a) Install the camshafts.
(See step 2 in cylinder head installation (2JZ-GE))
- (b) Using a dial indicator, measure the thrust clearance while moving the camshaft back and forth.
Standard thrust clearance:
0.080–0.190 mm (0.0031–0.0075 in.)
Maximum thrust clearance:
0.30 mm (0.0118 in.)

If the thrust clearance is greater than maximum, replace the camshaft. If necessary, replace the bearing caps and cylinder head as a set.

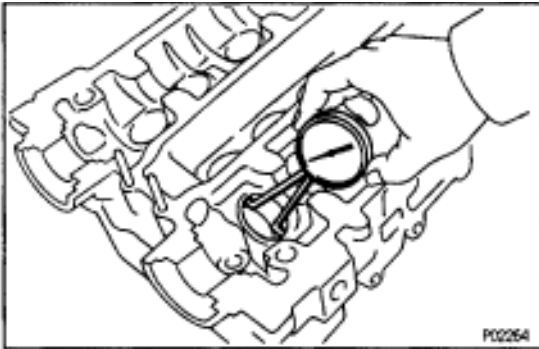

11. INSPECT VALVE LIFTERS AND LIFTER BORES

- (a) Using a caliper gauge, measure the lifter bore diameter of the cylinder head.
Lifter bore diameter:
31.000–31.016 mm (1.2205–1.2211 in.)
- (b) Using a micrometer, measure the lifter diameter.

Lifter diameter:
30.966–30.976 mm (1.2191–1.2195 in.)

- (c) Subtract the lifter diameter measurement from the lifter bore diameter measurement.
Standard oil clearance:
0.024–0.050 mm (0.0009–0.0020 in.)
Maximum oil clearance:
0.07 mm (0.0028 in.)

If the oil clearance is greater than maximum, replace the lifter. If necessary, replace the cylinder head.

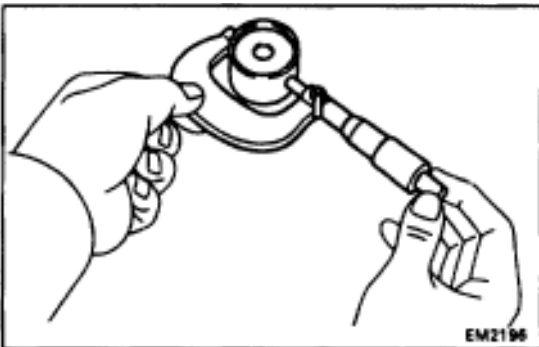

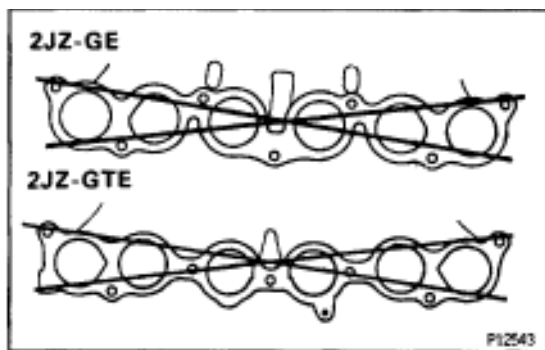
**12. INSPECT AIR INTAKE CHAMBER**

Using a precision straight edge and feeler gauge, measure the surfaces contacting the intake manifold for warpage.

Maximum warpage:

0.15 mm (0.0059 in.)

If warpage is greater than maximum, replace the chamber.

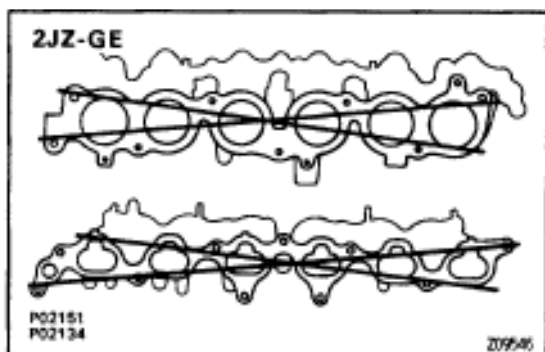
**13. INSPECT INTAKE MANIFOLD**

Using a precision straight edge and feeler gauge, measure the surfaces contacting the cylinder head and air intake chamber for warpage.

Maximum warpage:

0.15 mm (0.0059 in.)

If warpage is greater than maximum, replace the manifold.

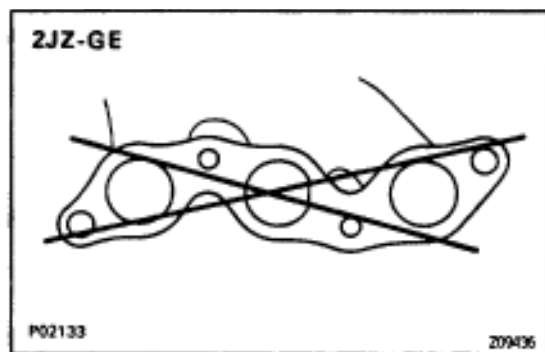
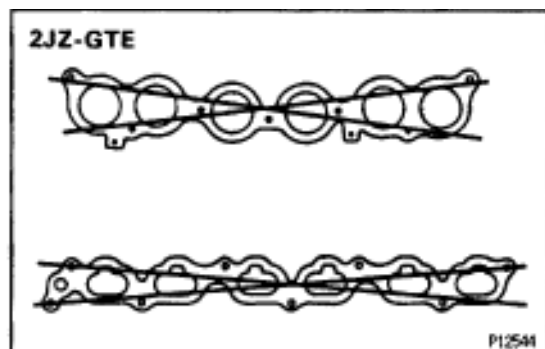
**14. 2JZ-GE:****INSPECT EXHAUST MANIFOLDS**

Using a precision straight edge and feeler gauge, measure the surfaces contacting the cylinder head for warpage.

Maximum warpage:

0.50 mm (0.0196 in.)

If warpage is greater than maximum, replace the manifold.

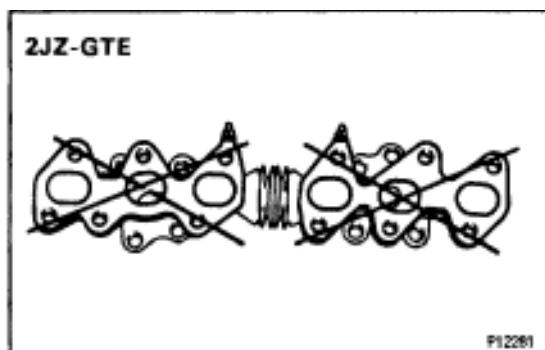
**15. 2JZ-GTE:****INSPECT EXHAUST MANIFOLD**

Using a precision straight edge and feeler gauge, measure the surfaces contacting the cylinder head for warpage.

Maximum warpage:

0.80 mm (0.0315 in.)

If warpage is greater than maximum, replace the manifold.

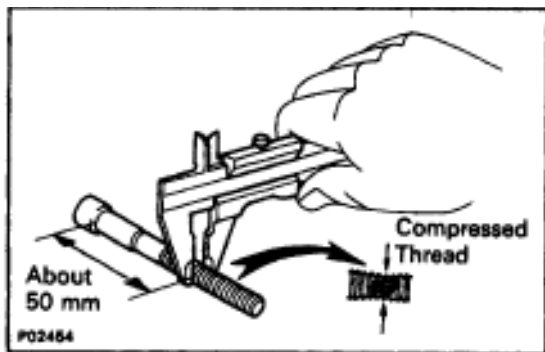

16. INSPECT CYLINDER HEAD BOLTS

Using a vernier caliper, measure the thread outside diameter of the bolt.

Standard outside diameter:

10.8–11.0 mm (0.425–0.433 in.)

Minimum outside diameter:

10.7 mm (0.421 in.)

If the diameter is less than minimum, replace the bolt.

CYLINDER HEAD ASSEMBLY

HINT:

- Thoroughly clean all parts to be assembled.
- Before installing the parts, apply new engine oil to all sliding and rotating surfaces.
- Replace all gaskets and oil seals with new ones.

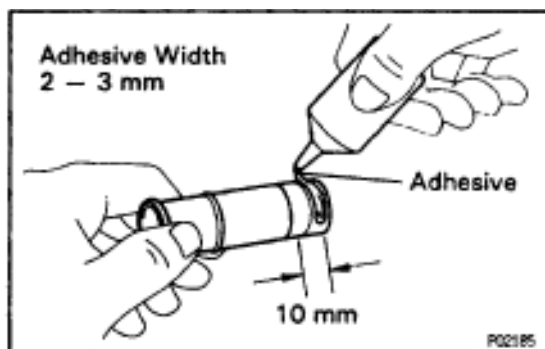

1. INSTALL HEATER UNION

HINT: When using a new cylinder head, a new heater union must be installed.

- (a) Apply adhesive to the end of the heater union as shown in the illustration.

Adhesive:

Part No. 08833-00070, THREE BOND 1324 or equivalent

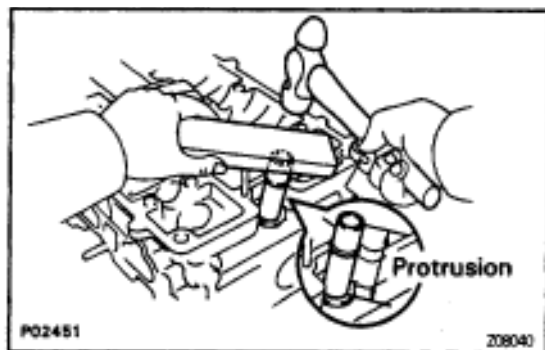

- (b) Using a wooden block and hammer, tap in a new heater union, leaving standard position protruding from the cylinder head.

Standard protrusion:

2JZ-GE

48 mm (1.89 in.)

2JZ-GTE

73 mm (2.87 in.)

NOTICE: Do not tap it in too far.

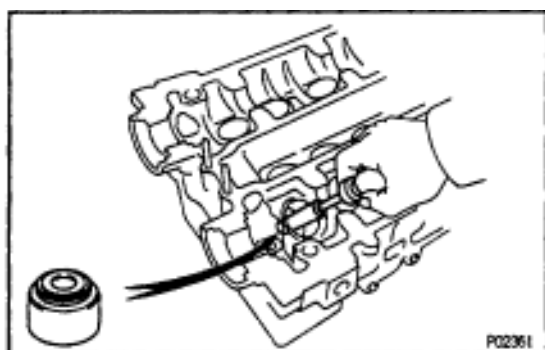

2. INSTALL VALVES

- (a) Install a new oil seal on the valve guide bushing.

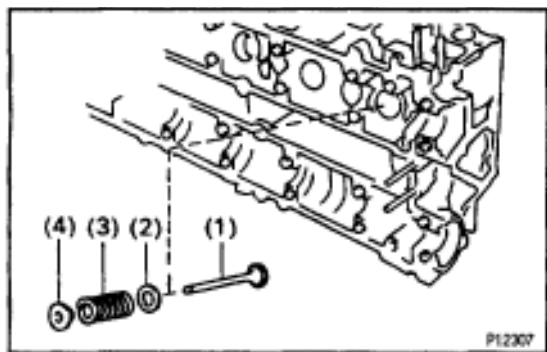

- (b) Install these parts:
- (1) Valve
 - (2) Spring seat
 - (3) Valve spring
 - (4) Spring retainer

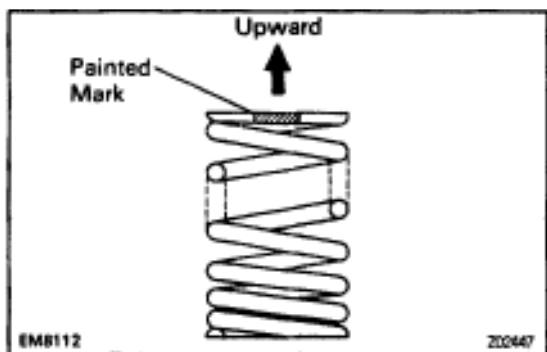

HINT: Install the valve spring, facing the painted mark upward.

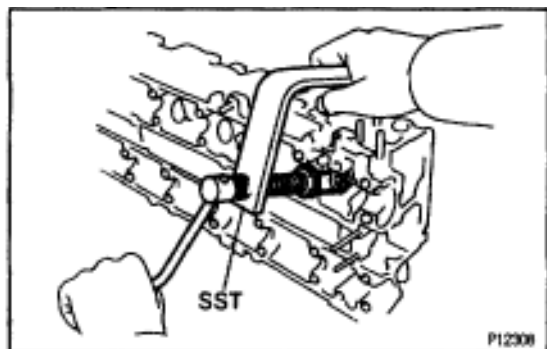

- (c) Using SST, compress the valve spring and place the 2 keepers around the valve stem.
SST 09202-70010

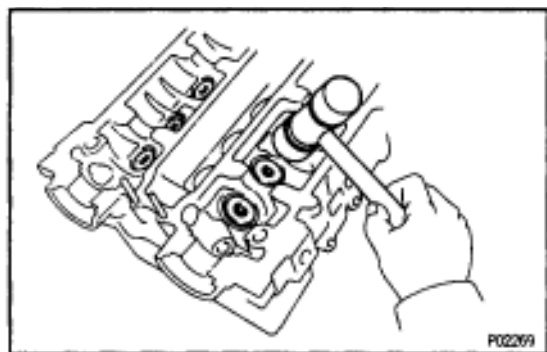

- (d) Using a plastic-faced hammer, lightly tap the valve stem tip to ensure a proper fit.

3. INSTALL VALVE LIFTERS AND SHIMS

- (a) Install the valve lifter and shim.
- (b) Check that the valve lifter rotates smoothly by hand.

4. INSTALL EGR COOLER

Install a new gasket and the EGR cooler with the 8 bolts.
Torque: 8.8 N·m (90 kgf·cm, 78 in·lbf)

5. 2JZ-GE:

INSTALL ECT SENSOR AND SENDER GAUGE

Torque: 20 N·m (200 kgf·cm, 14 ft·lbf)

6. 2JZ-GE:

INSTALL GROUND STRAP AND THROTTLE CABLE BRACKET

7. 2JZ-GE:

INSTALL ENGINE HANGERS

Torque: 39 N·m (400 kgf·cm, 29 ft·lbf)

8. 2JZ-GTE:

INSTALL CAMSHAFT POSITION SENSORS

Install the gasket and sensor with the 2 bolts.

Torque: 8.8 N·m (90 kgf·cm, 78 in·lbf)

9. 2JZ-GTE:

INSTALL ENGINE HANGERS AND GROUND STRAP

Torque: 39 N·m (400 kgf·cm, 29 ft·lbf)

CYLINDER HEAD INSTALLATION (2JZ-GE)

1. INSTALL CYLINDER HEAD

A. Place cylinder head on cylinder block

- (a) Place a new cylinder head gasket in position on the cylinder block.

NOTICE: Be sure to install it correctly.

- (b) Place the cylinder head in position on the cylinder head gasket.

B. Install cylinder head bolts

HINT:

- The cylinder head bolts are tightened in 2 progressive steps (steps (c) and (f)).
- If any of bolts break or deform, replace them.

- (a) Apply a light coat of engine oil on the threads and under the heads of the cylinder head bolts.
- (b) Install the 14 plate washers to each cylinder head bolt.
- (c) Using a 10 mm bi-hexagon wrench, uniformly tighten the cylinder head bolts, in several passes, in the sequence shown.

Torque: 34 N·m (350 kgf·cm, 25 ft·lbf)

If any of the bolts do not meet the torque specification, replace the bolt.

- (d) Mark the front of the cylinder head bolt head with paint.

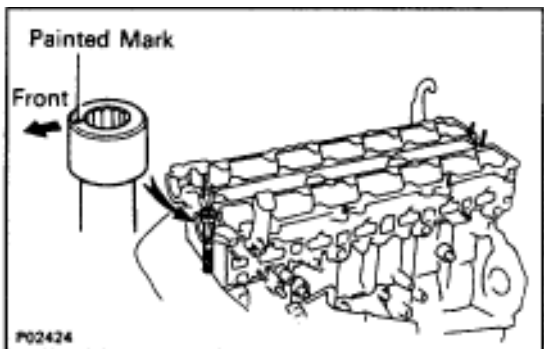
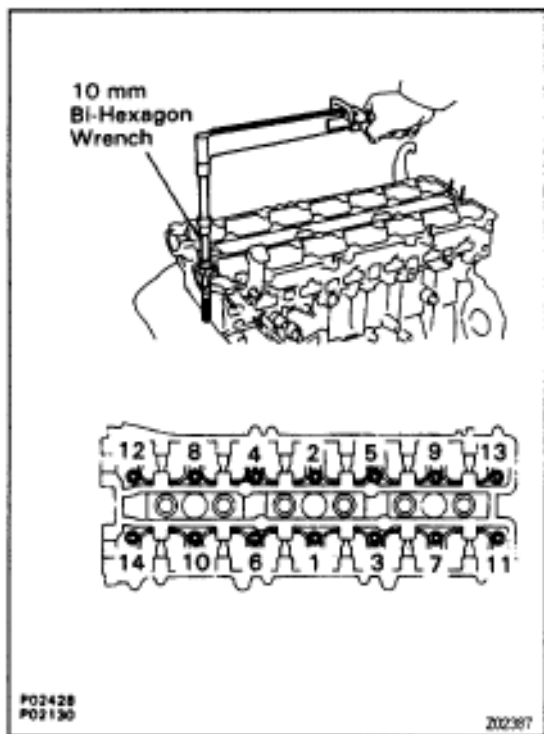
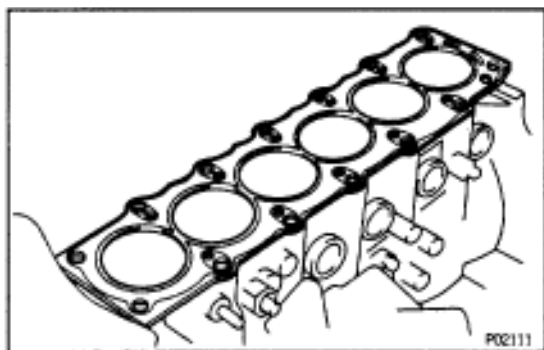

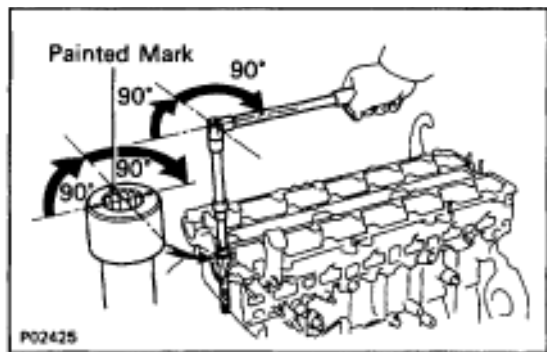

- (e) Retighten the cylinder head bolts by 90° in the numerical order shown in the illustration on previous page.
- (f) Retighten cylinder head bolts by an additional 90° shown in the illustration on previous page.
- (g) Check that the painted mark is now turned to the rear.

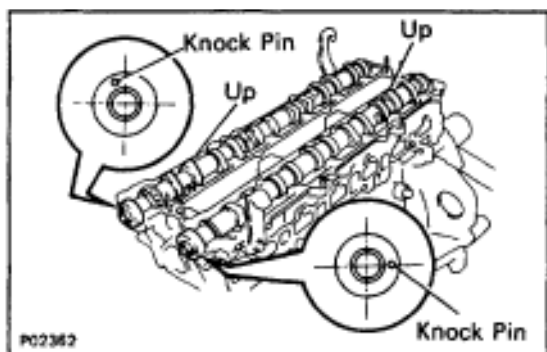

2. INSTALL CAMSHAFTS

- (a) Apply engine oil to the thrust portion of the camshaft.
- (b) Place the camshaft on the cylinder head with the cam lobe facing up as shown.

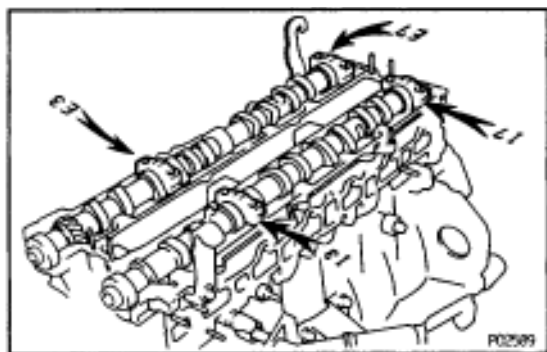

- (c) Place the No.3 and No.7 bearing caps in their proper location.

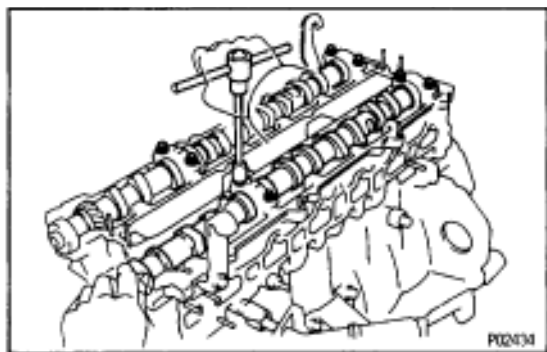

- (d) Apply a light coat of engine oil on the threads and under the heads of the bearing cap bolts.
- (e) Temporarily tighten these bearing cap bolts uniformly and alternately, in several passes, until the bearing caps are snug with the cylinder head.

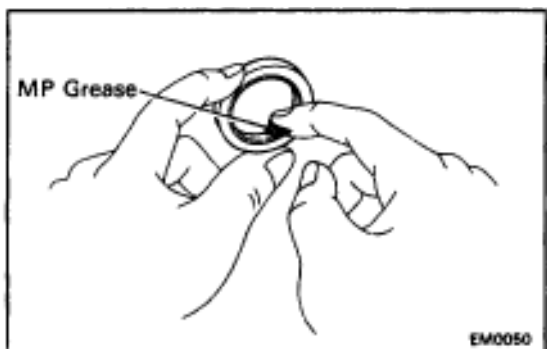

- (f) Apply MP grease to a new camshaft oil seal lip.

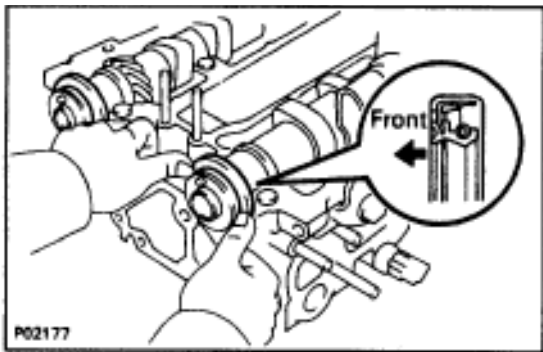

(g) Install the 2 oil seals to the camshafts.

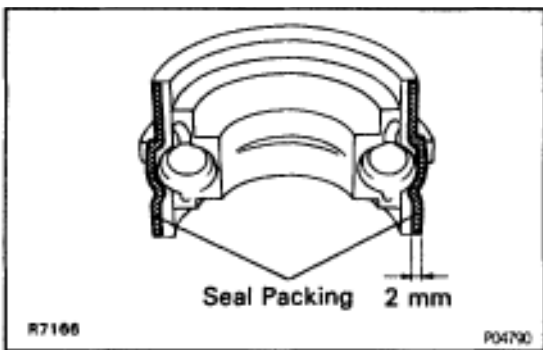

(h) Clean the installed surfaces of the No.1 bearing cap and cylinder head with cleaner.

(i) Apply seal packing to the No.1 bearing cap as shown.

Seal packing:

Part No. 08826-00080 or equivalent

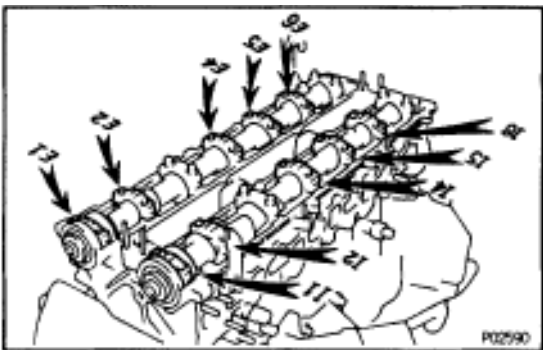

(j) Install the No.1, No.2, No.4, No.5 and No.6 bearing caps in their proper locations.

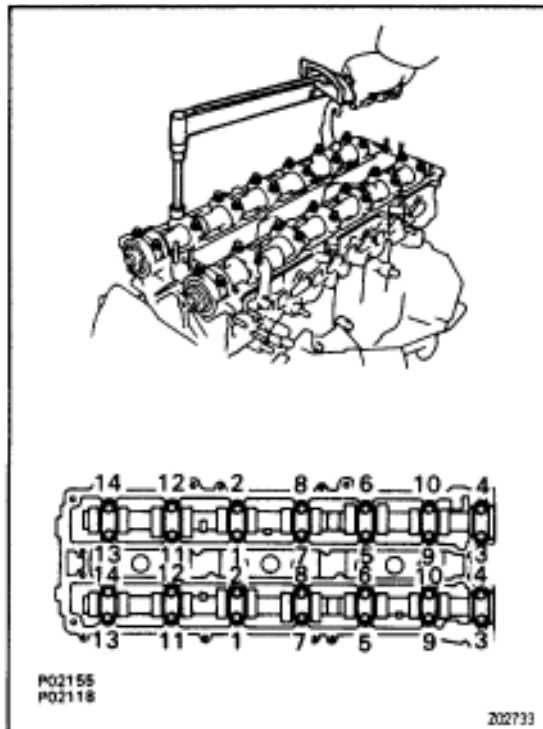

(k) Apply a light coat of engine oil on the threads and under the heads of the bearing cap bolts.

(l) Install and uniformly tighten the 14 bearing cap bolts on one side, in several passes, in the sequence shown.

Torque: 20 N·m (200 kgf·cm, 14 ft·lbf)

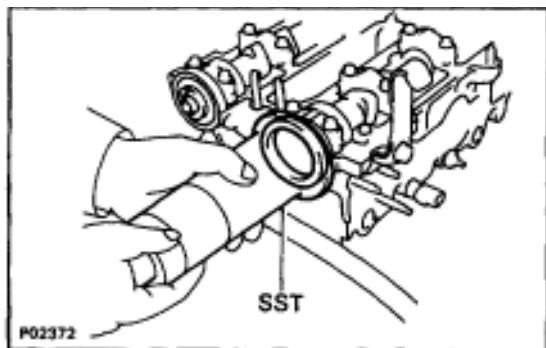

- (m) Using SST, push the 2 oil seals in as far as they can go.
SST 09316-60010 (09316-00010, 09316-00050)

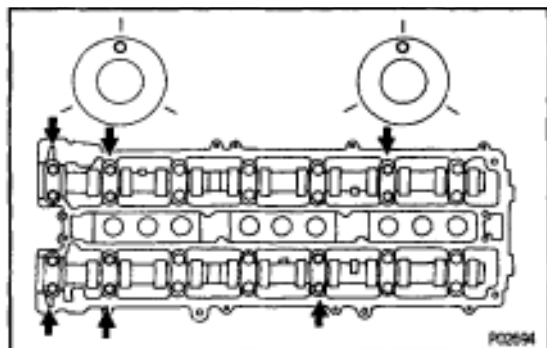

- (n) Rotate the camshaft with a wrench at the hexagon position, bring the forward straight pin up.
(o) Loosen the 3 bearing cap bolts as shown, until they can be turned by hand; retighten, in several passes.
Torque: 20 N·m (200 kgf·cm, 14 ft·lbf)

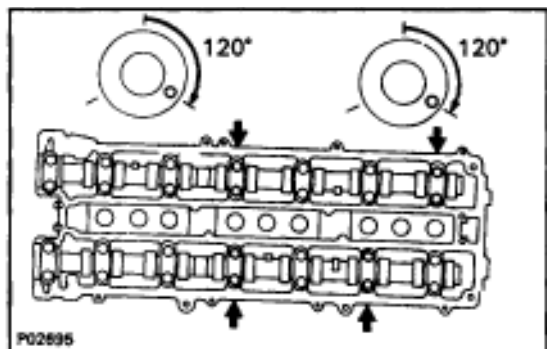

- (p) Turn the camshaft 1/3 of revolution.
(q) Loosen the 2 bearing cap bolts as shown, until they can be turned by hand; retighten, in several passes.
Torque: 20 N·m (200 kgf·cm, 14 ft·lbf)

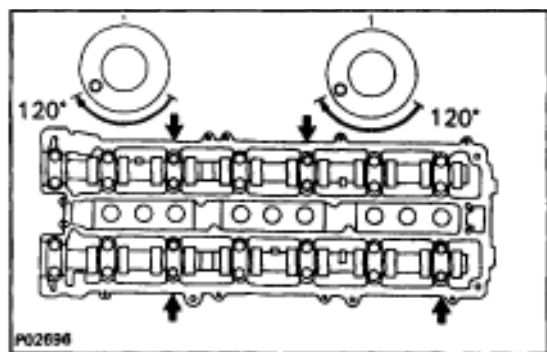

- (r) Turn the camshaft a further 1/3 of a revolution.
(s) Loosen the 2 bearing cap bolts as shown, until they can be turned by hand; retighten, in several passes.
Torque: 20 N·m (200 kgf·cm, 14 ft·lbf)

3. CHECK AND ADJUST VALVE CLEARANCE

(See steps 5 to 6 in valve clearance inspection and adjustment)

Turn the camshaft, and position the cam lobe upward, check and adjust the valve clearance.

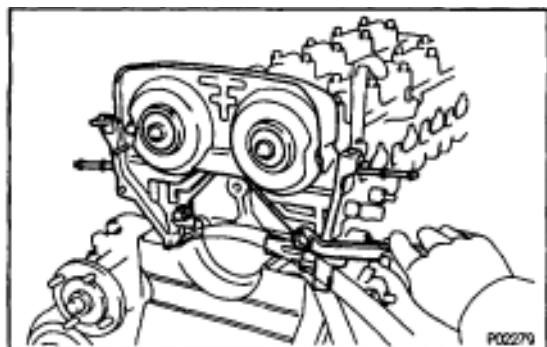

4. INSTALL NO.4 TIMING BELT COVER

Install the timing belt cover with 4 bolts.

Torque: 8.8 N·m (90 kgf·cm, 78 in·lbf)

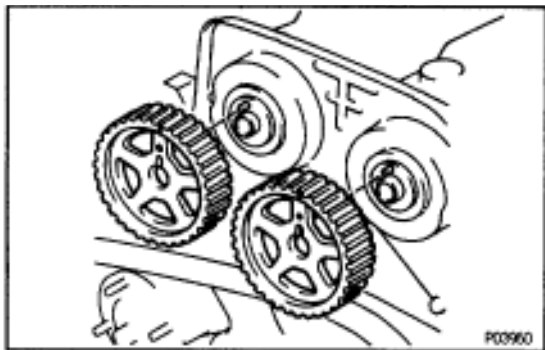

5. INSTALL CAMSHAFT TIMING PULLEYS

- (a) Align the camshaft knock pin with the groove in the pulley, and slide on the pulley.
- (b) Temporarily install the timing pulley bolt.

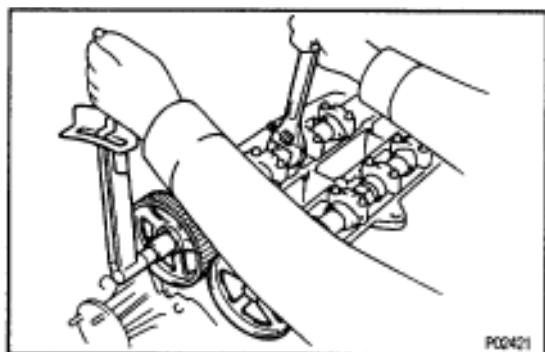

- (c) Hold the hexagon portion of the camshaft with a wrench, and tighten the timing pulley bolt.

Torque: 79 N·m (810 kgf·cm, 59 ft·lbf)

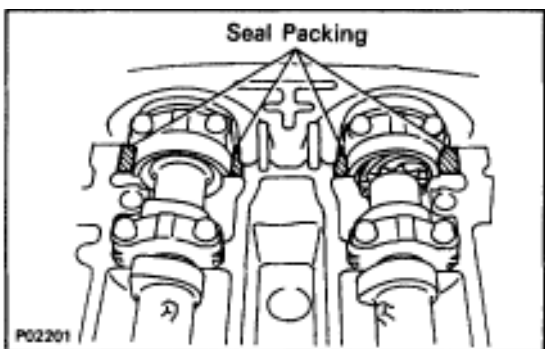

6. INSTALL NO.3, NO.1 AND NO.2 CYLINDER HEAD COVERS

- (a) Remove any old packing (FIPG) material.
- (b) Apply seal packing to the cylinder head as shown in the illustration.

Seal packing:

Part No. 08826-00080 or equivalent

- (c) Install the gaskets to the No.1 and No.2 cylinder head covers.
- (d) Install the No.2 cylinder head cover with the 4 bolts.
Torque: 8.3 N·m (85 kgf·cm, 74 in·lbf)
- (e) Install the No.1 cylinder head cover with the 4 bolts.
Torque: 8.3 N·m (85 kgf·cm, 74 in·lbf)
- (f) Install the No.3 cylinder head cover with the 4 bolts and 4 nuts.

Torque: 8.3 N·m (85 kgf·cm, 74 in·lbf)

- (g) Install the PCV valve.

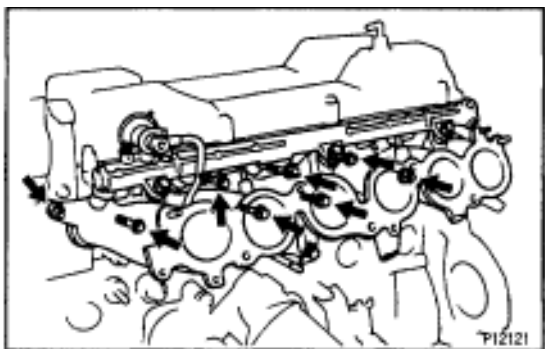

7. INSTALL INTAKE MANIFOLD AND DELIVERY PIPE ASSEMBLY

Install a new gasket, the intake manifold and delivery pipe assembly with the 6 bolts and 2 nuts.

Torque: 27 N·m (280 kgf·cm, 20 ft·lbf)

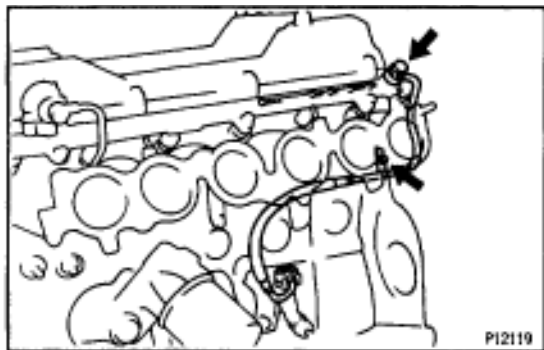
**8. INSTALL FUEL INLET PIPE**

- (a) Connect the fuel inlet pipe with 2 new gaskets and the union bolt.

Torque: 42 N·m (420 kgf·cm, 30 ft·lbf)

- (b) Install the clamp bolt to the intake manifold.

9. INSTALL FUEL PRESSURE PULSATION DAMPER

(See fuel pressure pulsation damper installation in SFI System)

10. INSTALL INTAKE MANIFOLD STAY

Torque: 39 N·m (400 kgf·cm, 29 ft·lbf)

11. INSTALL WATER OUTLET AND NO.1 BYPASS HOSE ASSEMBLY**12. CONNECT ENGINE WIRE**

- (a) Install the engine wire protector to the intake manifold with the 3 nuts.

- (b) Connect these connectors:

- 6 injector connectors

HINT: The No.1, No.3 and No.5 injector connectors are dark gray, and the No.2, No.4 and No.6 injector connectors are gray.

- ECT sensor connector
- ECT sender gauge connector

- (c) Install the 2 wire clamps to the intake manifold with the bolts.

- (d) Install the 2 ground straps to the intake manifold with the bolts.

- (e) Install the engine wire bracket to the water pump with the bolt.

13. INSTALL VACUUM CONTROL VALVE SET

Torque: 21 N·m (210 kgf·cm, 15 ft·lbf)

14. INSTALL AIR INTAKE CHAMBER

- (a) Install a new gasket and the intake chamber with the 5 bolts and nut.

Torque: 27 N·m (280 kgf·cm, 20 ft·lbf)

- (b) Install the bolt holding the engine wire protector to the air intake chamber.

- (c) Except California:

Connect the vacuum sensing hose to the fuel pressure regulator.

15. INSTALL STARTER

(See starter removal in Starting System)

16. INSTALL OIL DIPSTICK GUIDES FOR ENGINE AND TRANSMISSION

- (a) Install a new O-ring to the dipstick guide.

- (b) Apply soapy water to the O-ring.

- (c) Connect the dipstick guide end to the oil pan.

- (d) Install the 2 dipstick guides with the 2 bolts.

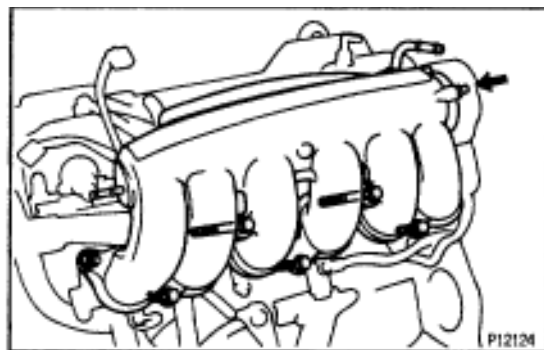
17. INSTALL ENGINE WIRE BRACKET**18. CONNECT FUEL RETURN HOSE**

19. **INSTALL WATER BYPASS OUTLET AND NO.1 WATER BYPASS PIPE**
(See step 3 in water pump installation in Cooling System)
20. **INSTALL TIMING BELT**
(See steps 11 to 17 in timing belt removal)
21. **INSTALL SPARK PLUGS**
22. **INSTALL DISTRIBUTOR AND CORDS ASSEMBLY**
(See steps 2, 3 and 5 in distributor installation in Ignition System)
23. **CONNECT HIGH-TENSION CORDS TO CYLINDER HEAD COVERS**
(See step 1 in high-tension cords and cord clamps installation in Ignition System)
24. **INSTALL NO.3 TIMING BELT COVER**
25. **INSTALL CYLINDER HEAD REAR COVER**
26. **INSTALL NO.2 VACUUM PIPE AND VSV ASSEMBLY**

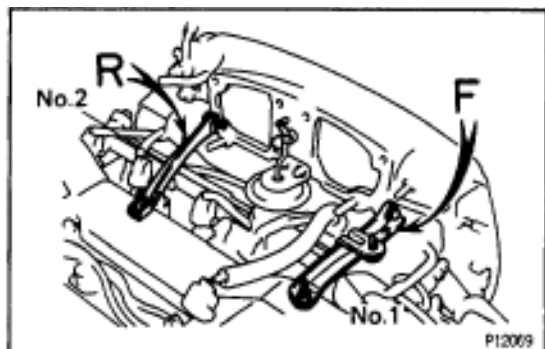

27. **INSTALL AIR INTAKE CHAMBER STAYS**
HINT: The No.1 stay is marked with "F", and No.2 stay is marked with "R".
 - (a) Install the No.1 stay with the bolt and nut.
Torque: 18 N·m (185 kgf·cm, 13 ft·lbf)
 - (a) Install the No.2 stay with the bolt and nut.
Torque: 18 N·m (185 kgf·cm, 13 ft·lbf)
28. **INSTALL THROTTLE BODY AND INTAKE AIR CONNECTOR ASSEMBLY**
(See in injector removal in SFI System)
29. **CONNECT EVAP HOSE**
30. **CONNECT BRAKE BOOSTER VACUUM HOSE**
31. **INSTALL PS PUMP**
 - (a) Install the pump rear stay with the 2 bolts.
Torque: 39 N·m (400 kgf·cm, 29 ft·lbf)
 - (b) Install the pump housing with the 2 bolts.
Torque: 58 N·m (590 kgf·cm, 43 ft·lbf)
 - (c) Connect these hoses:
 - Air hose to No.4 timing belt cover
 - Air hose to air intake chamber



32. **INSTALL EXHAUST MANIFOLDS**
 - (a) Install a new gasket and the exhaust manifold with 4 new nuts. Install the No.1 and No.2 exhaust manifolds.
Torque: 39 N·m (400 kgf·cm, 29 ft·lbf)
 - (b) Connect the 2 (main heated) oxygen sensor connectors.
 - (c) Except California:
Install the manifold heat insulator with the 4 nuts.

33. **INSTALL NO.2 FRONT EXHAUST PIPE**
(See step 6 in engine installation in Engine Mechanical)
34. **INSTALL DRIVE BELT**
35. **INSTALL AIR CLEANER, VAF METER AND INTAKE AIR CONNECTOR PIPE ASSEMBLY**
(See step 22 in engine installation in Engine Mechanical)
36. **INSTALL AIR CLEANER DUCT**
37. **FILL WITH ENGINE COOLANT**
38. **START ENGINE AND CHECK FOR LEAKS**
39. **CHECK IGNITION TIMING**
(See steps 8 to 12 in distributor installation in Ignition System)
40. **INSTALL ENGINE UNDER COVER**
41. **PERFORM ROAD TEST**
Check for abnormal noise, shock, slippage, correct shift points and smooth operation.
42. **RECHECK ENGINE COOLANT LEVEL**

CYLINDER HEAD INSTALLATION (2JZ-GTE)

1. **INSTALL CYLINDER HEAD**
(See step 1 in cylinder head installation (2JZ-GE))
2. **INSTALL CAMSHAFTS**
(See step 2 ((a) to (m)) in cylinder head installation (2JZ-GE))
3. **CHECK AND ADJUST VALVE CLEARANCE**
(See steps 5 to 6 in valve clearance inspection and adjustment)
Turn the camshaft, and position the cam lobe upward, check and adjust the valve clearance.
4. **INSTALL NO.4 TIMING BELT COVER**
(See step 4 in cylinder head installation (2JZ-GE))
5. **INSTALL CAMSHAFT TIMING PULLEYS**
(See step 5 in cylinder head installation (2JZ-GE))

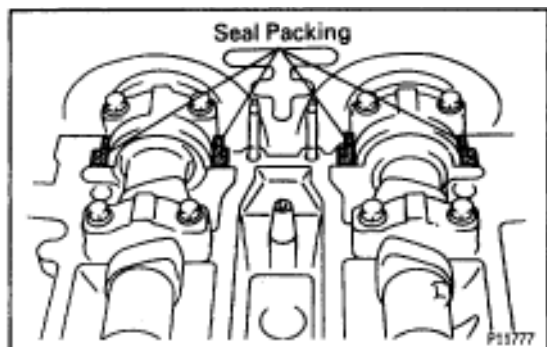

6. **INSTALL NO.1 AND NO.2 CYLINDER HEAD COVERS**
 - (a) Remove any old packing (FIPG) material.
 - (b) Apply seal packing to the cylinder head as shown in the illustration.
Seal packing:
Part No. 08826-00080 or equivalent
 - (c) Install the gaskets to the No.1 and No.2 cylinder head covers.

- (d) Install the seal washers to the mounting bolts.
 - (e) Install the No.2 cylinder head cover with the 4 seal washers and 4 bolts.
Torque: 5.4 N·m (55 kgf·cm, 48 in·lbf)
 - (f) Install the No.1 cylinder head cover with the 4 seal washers and 4 bolts.
Torque: 5.4 N·m (55 kgf·cm, 48 in·lbf)
 - (g) Install the PCV valve.
 - (h) Install the cruise control actuator cable bracket and IAC valve pipe clamp with the 2 bolts.
7. **INSTALL SPARK PLUGS**
 8. **INSTALL IGNITION COILS ASSEMBLIES**
(See ignition coils installation in Ignition System)
 9. **INSTALL TIMING BELT**
(See steps 11 to 17 in timing belt installation)

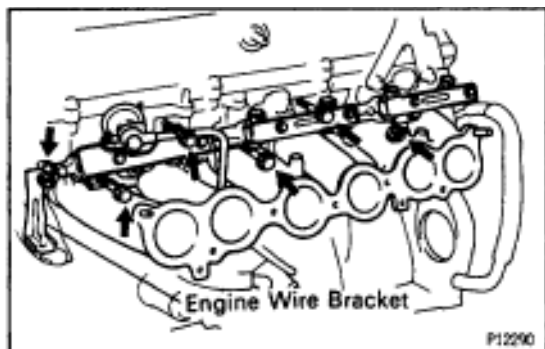

10. INSTALL INTAKE MANIFOLD AND DELIVERY PIPE ASSEMBLY

- Install a new gasket, the intake manifold, delivery pipe assembly and engine wire bracket with the 4 bolts and 2 nuts.
Torque: 27 N·m (280 kgf·cm, 20 ft·lbf)

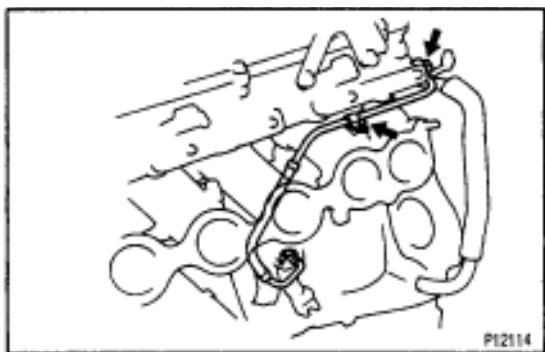

11. INSTALL FUEL INLET PIPE

- (a) Connect the fuel inlet pipe with 2 new gaskets and the union bolt.

Torque: 42 N·m (420 kgf·cm, 30 ft·lbf)

- (b) Install the clamp bolt to the intake manifold.

12. INSTALL FUEL PRESSURE PULSATION DAMPER (See fuel pressure pulsation damper installation in SFI System)

13. INSTALL PRESSURE TANK AND VSV ASSEMBLY

Torque: 21 N·m (210 kgf·cm, 15 ft·lbf)

14. INSTALL STATER

(See starter installation in Starting System)

15. CONNECT ENGINE WIRE

- (a) Install the engine wire protector to the intake manifold with the nut.
- (b) Install the 2 ground straps to the intake manifold with the bolts.
- (c) Connect these connectors and clamps:
 - VSV connector fo EVAP

- 6 injector connectors
- HINT: The No.1, No.3 and No.5 injector connectors are dark gray, and the No.2, No.4 and No.6 injector connectors are gray.
- 2 camshaft position sensor connectors
 - 3 engine wire clamps to injector holders
16. **INSTALL AIR INTAKE CHAMBER ASSEMBLY**
(See injector installation in SFI System)
 17. **CONNECT FUEL RETURN HOSE**
 18. **INSTALL PS PUMP**
Torque: 58 N·m (590 kgf·cm, 43 ft·lbf)
 19. **INSTALL WATER OUTLET AND NO.1 WATER BYPASS PIPE**
 - (a) Install 2 new O-rings to the No.1 water bypass pipe.
 - (b) Apply soapy water to the O-rings.
 - (c) Install the No.1 water bypass pipe to the water pump.
 - (d) Install a new gasket and the water outlet with the 2 bolts.
Torque: 21 N·m (210 kgf·cm, 15 ft·lbf)
 - (e) Connect the ECT sensor and sender gauge connectors.
 - (f) Connect the upper radiator hose to the water outlet.
 20. **INSTALL DRIVE BELT**
Install the drive belt by turning the drive belt tensioner clockwise.
 21. **M/T:**
INSTALL DRIVE BELT TENSIONER DAMPER
(See step 19 in timing belt installation)

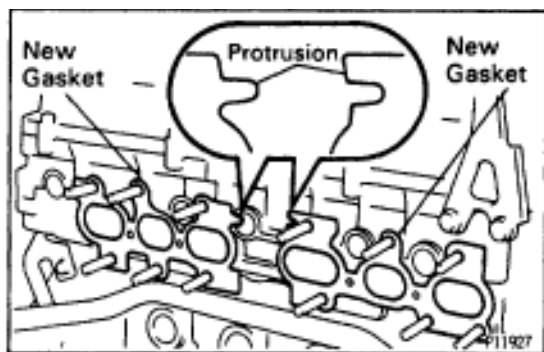

22. **INSTALL EXHAUST MANIFOLD**
 - (a) Place 2 new gaskets to the cylinder head facing the protrusion as shown.

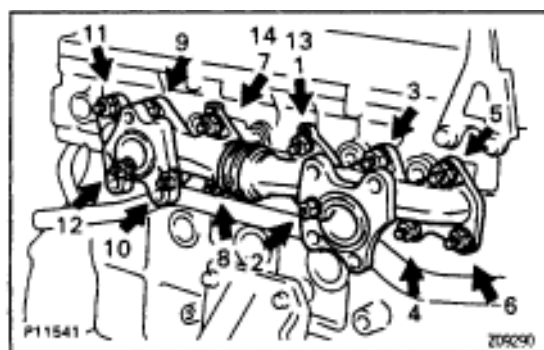

- (b) Install the exhaust manifold with 12 new nuts, in several passes, in the sequence shown.
Torque: 39 N·m (400 kgf·cm, 29 ft·lbf)
23. **INSTALL TURBOCHARGER**
(See turbocharger installation in Turbocharger System)

CYLINDER BLOCK COMPONENTS FOR ENGINE REMOVAL AND INSTALLATION

2JZ-GE

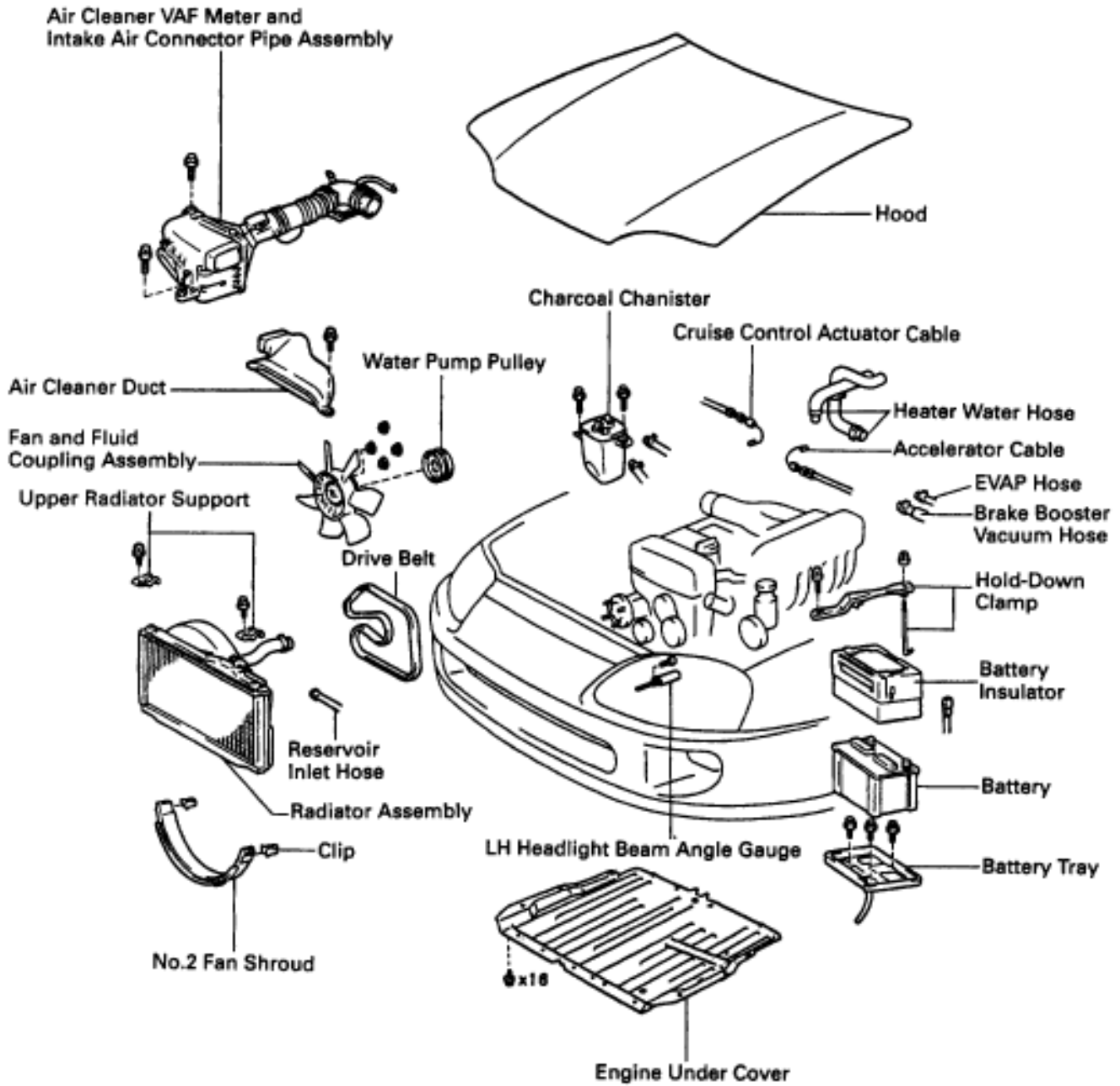

2JZ-GE

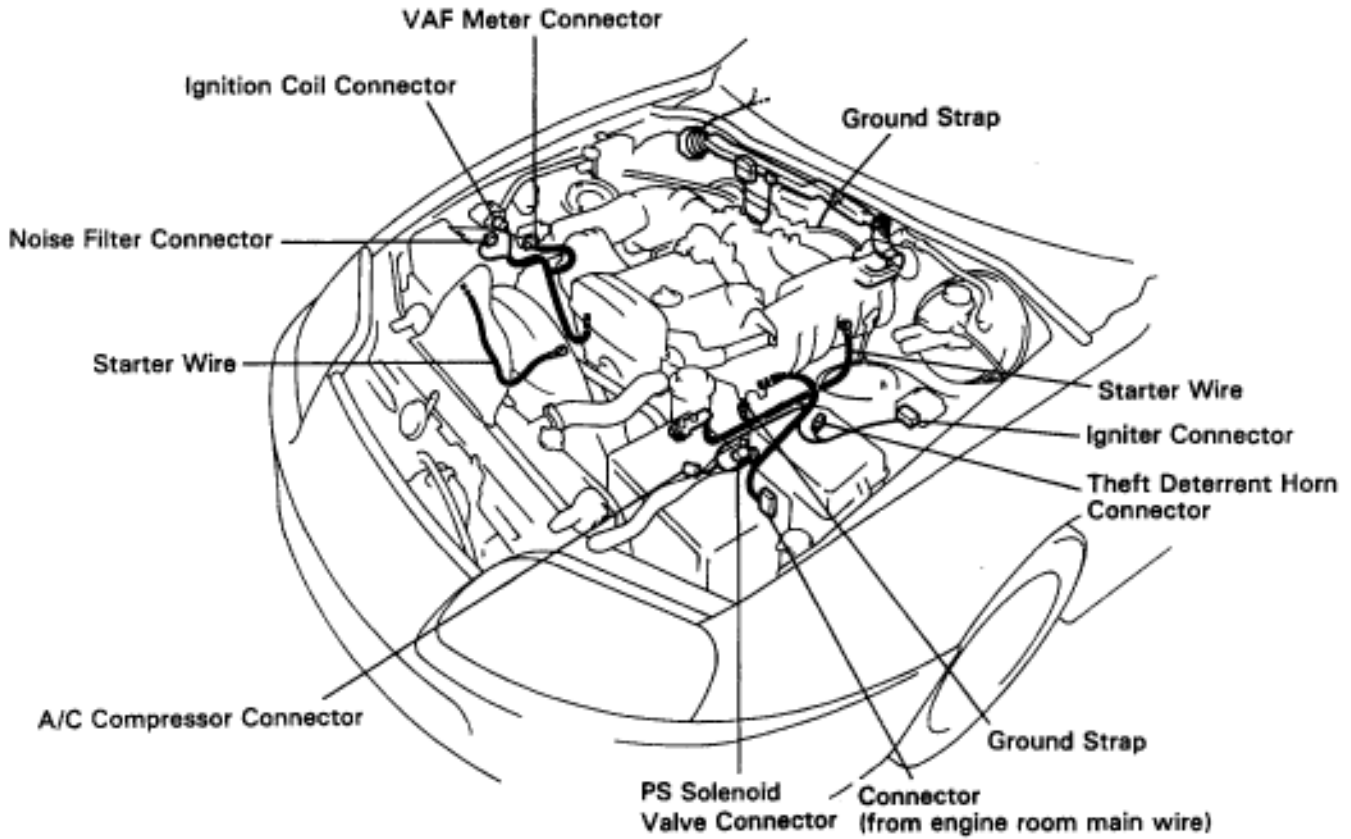

P13077

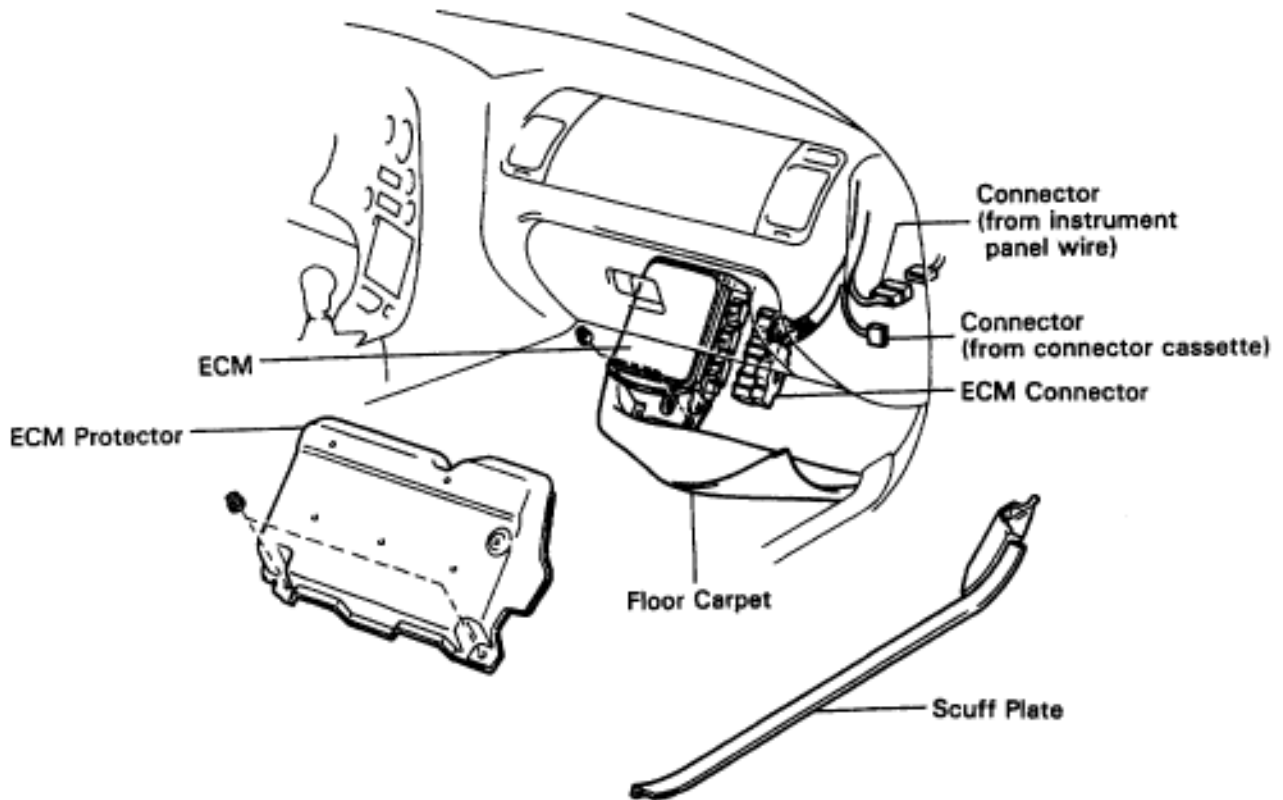

P13166

2JZ-GE

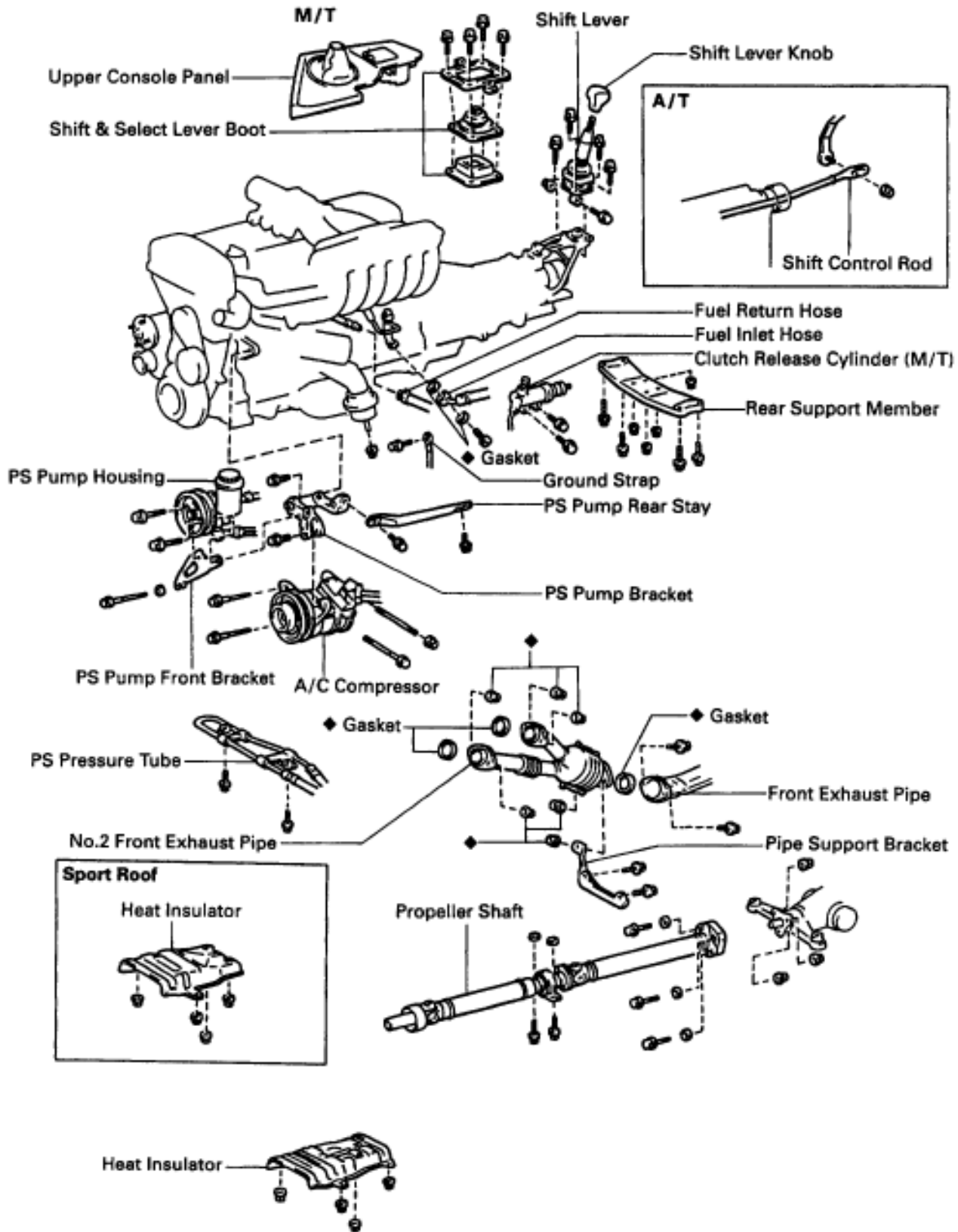

◆ Non-reusable part

2JZ-GTE

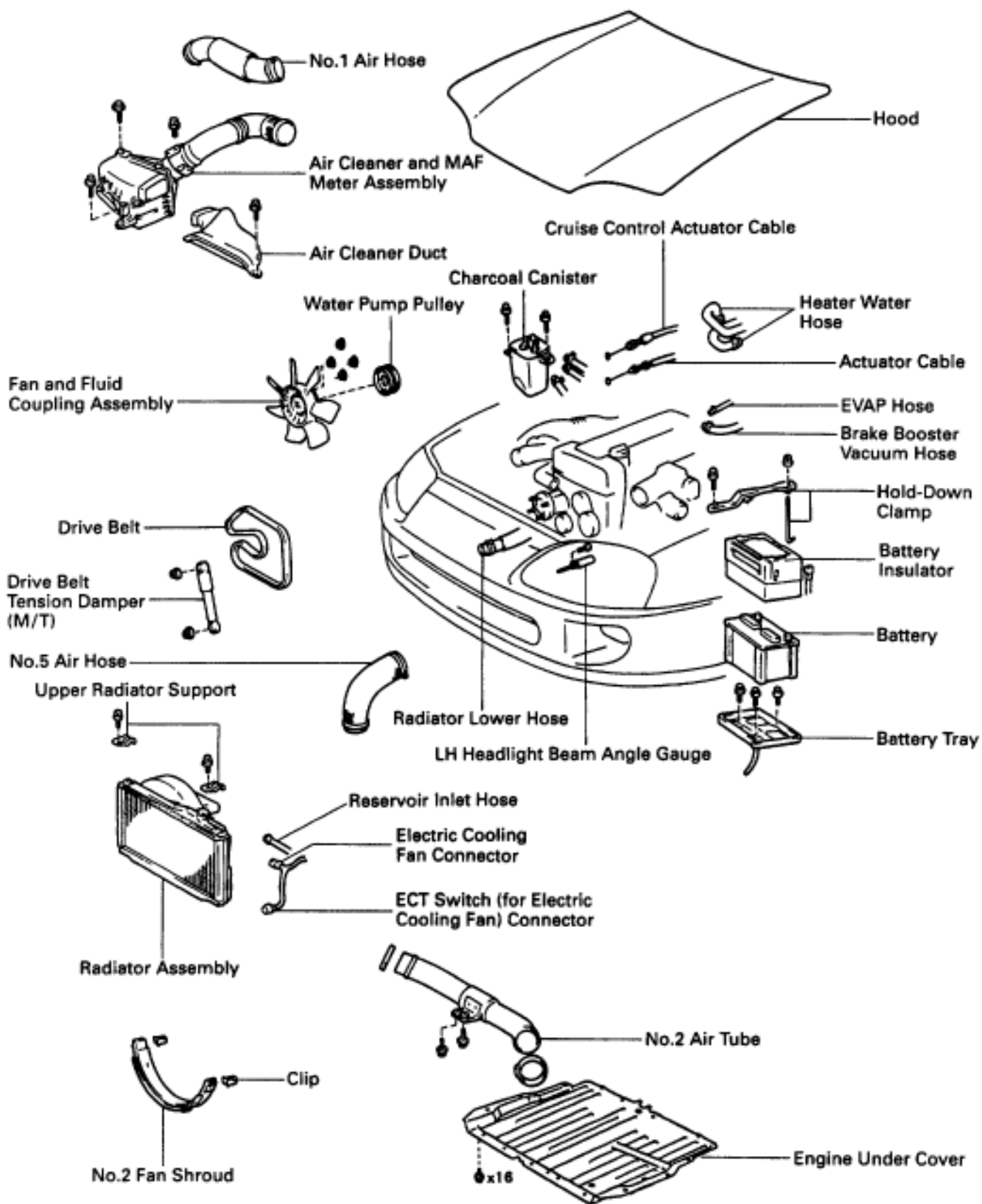

2JZ-GTE

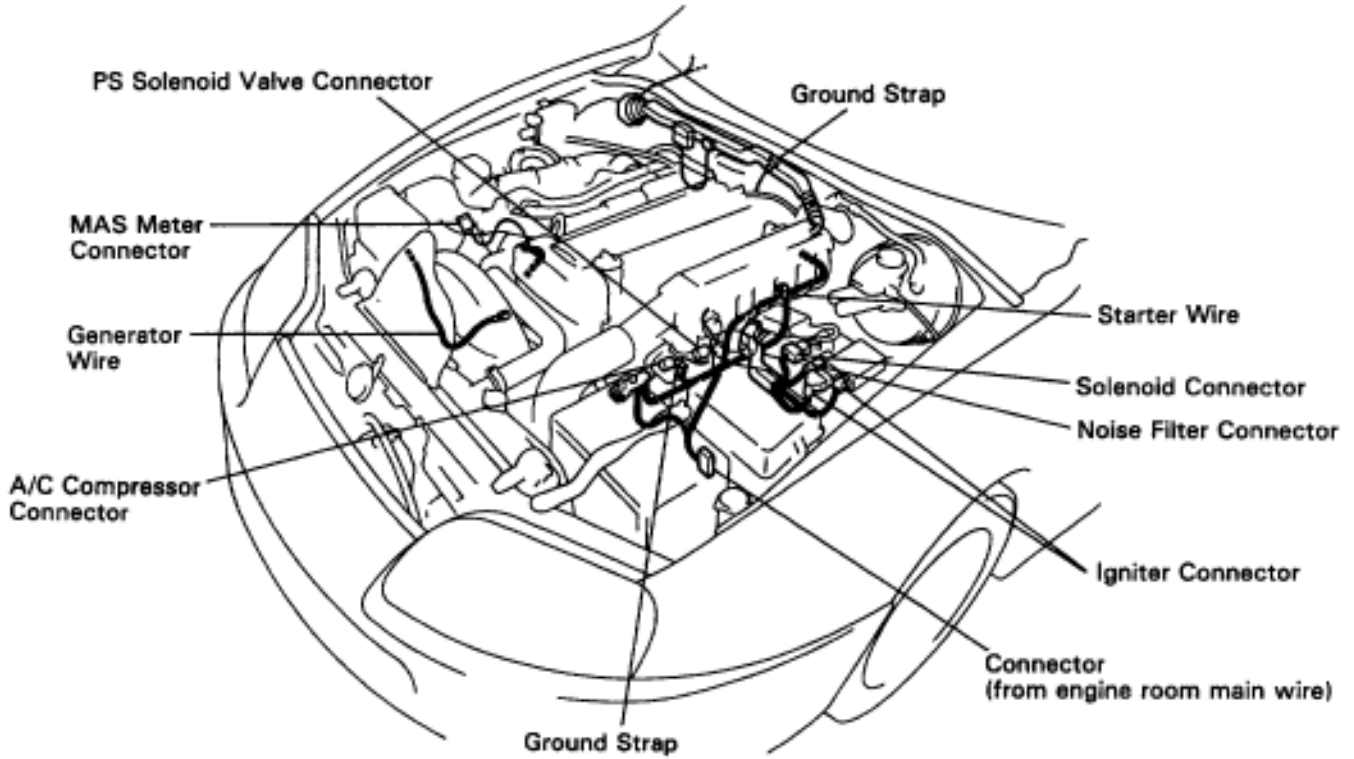

P13078

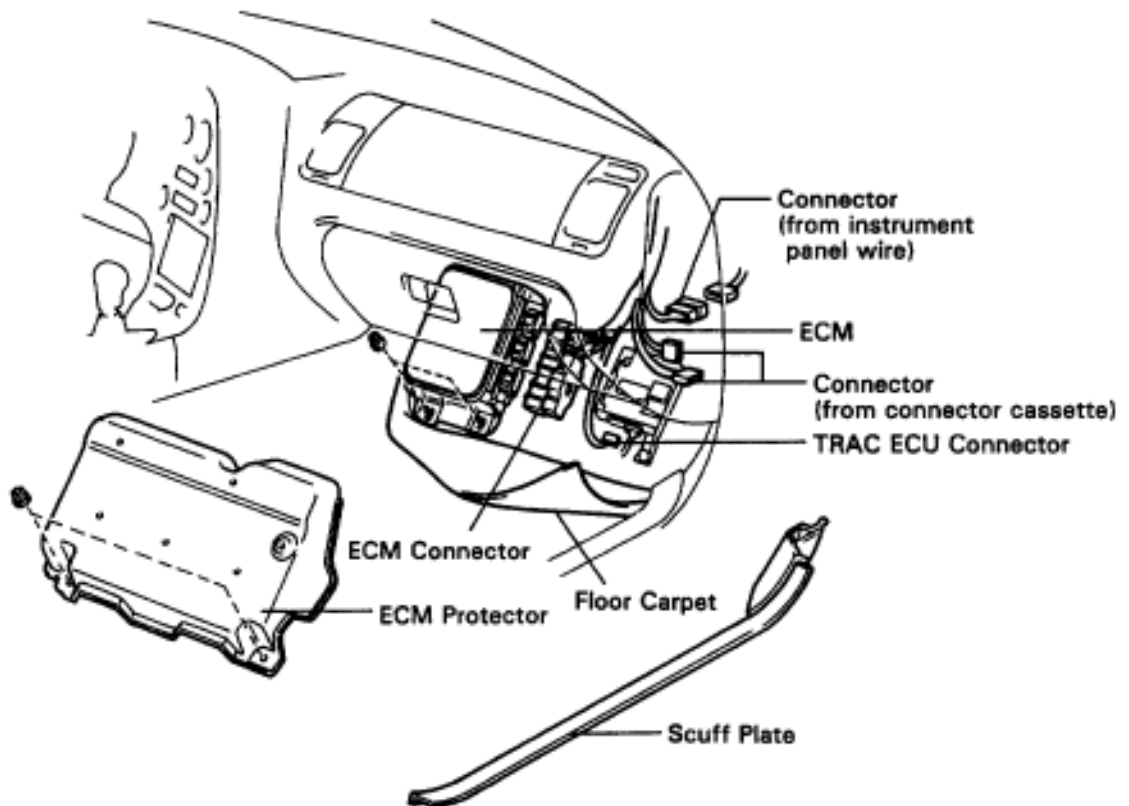

P13167

2JZ-GTE

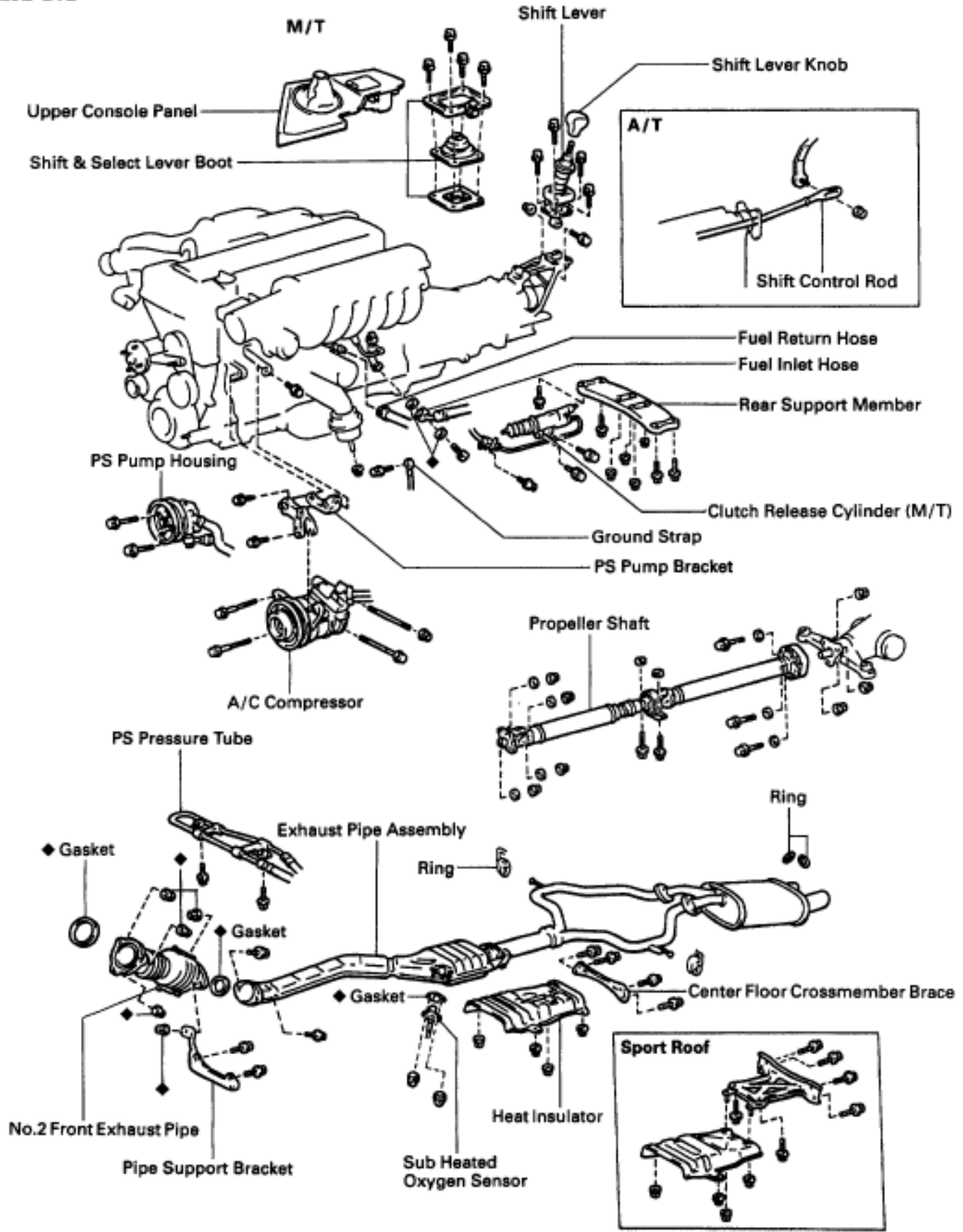

◆ Non-reusable part

ENGINE REMOVAL (2JZ-GE)

1. REMOVE HOOD
2. REMOVE RADIATOR ASSEMBLY
(See radiator removal in Cooling System)
3. DRAIN ENGINE OIL
4. DRAIN FUEL FROM FUEL TANK
5. DISCONNECT CONTROL CABLES FROM THROTTLE BODY

Disconnect these cables:

- Accelerator cable
- Cruise control actuator cable

6. REMOVE AIR CLEANER, VAF METER AND INTAKE AIR CONNECTOR PIPE ASSEMBLY

- (a) Disconnect the high-tension cord from the ignition coil.
- (b) Disconnect the high-tension cord from the clamp on the air cleaner.
- (c) Disconnect the VAF meter connector.
- (d) Disconnect the engine wire from the VAF meter.
- (e) Disconnect these hoses:
 - (1) PS air hose from No.4 timing belt cover
 - (2) PCV hose from No.2 cylinder head cover
- (f) Loosen the hose clamp bolt holding the intake air connector pipe to the throttle body.
- (g) Remove the 3 bolts, air cleaner, VAF meter and intake air connector pipe assembly.

7. REMOVE DRIVE BELT, FAN, FLUID COUPLING ASSEMBLY AND WATER PUMP PULLEY
(See step 6 in water pump removal in Cooling System)

8. REMOVE CHARCOAL CANISTER

9. DISCONNECT HEATER WATER HOSES

10. DISCONNECT BRAKE BOOSTER VACUUM HOSE

11. DISCONNECT EVAP HOSE

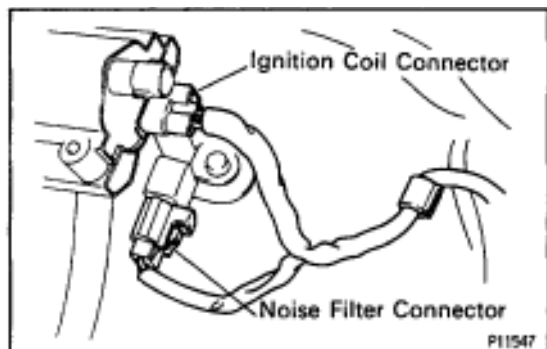
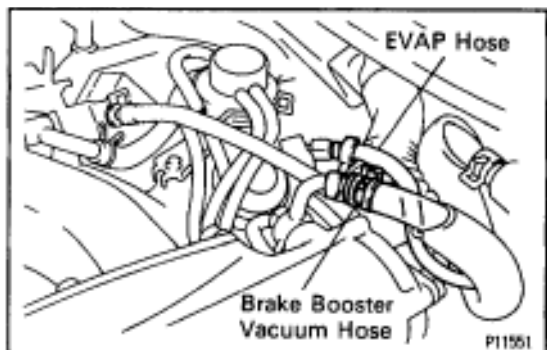
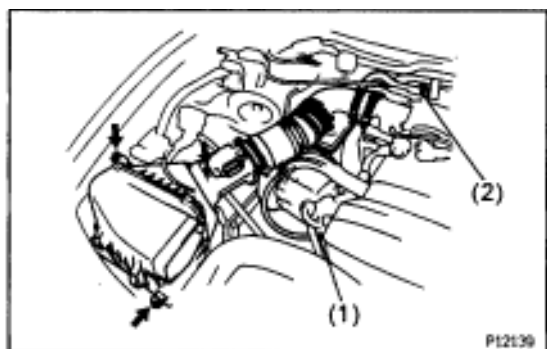
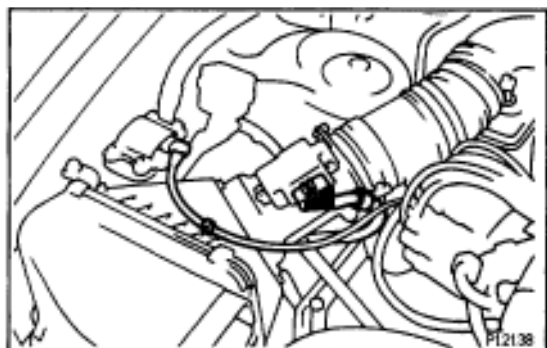

12. DISCONNECT WIRES AND CONNECTORS

- (a) Disconnect the noise filter connector.
- (b) Disconnect the ignition coil connector.
- (c) Disconnect the engine wire from the wire clamp.

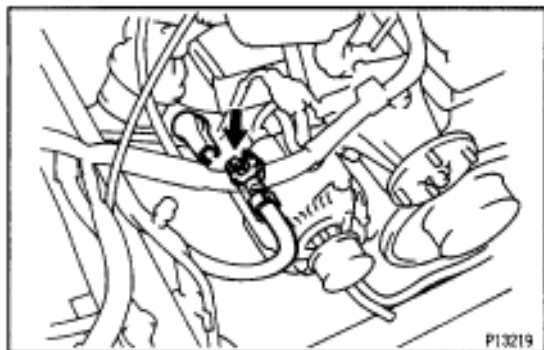

- (d) Remove the rubber cap and nut, and disconnect the generator wire.

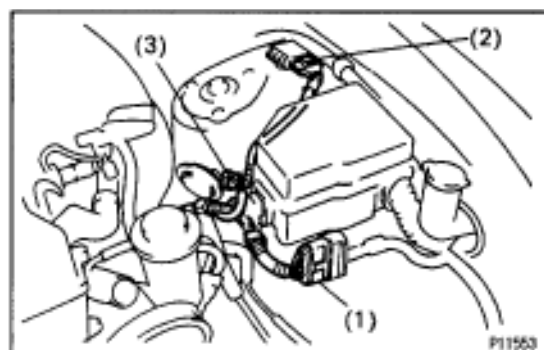

- (e) Disconnect these connectors:
 (1) Connector from engine room main wire
 (2) Igniter connector
 (3) Theft deterrent horn connector
 (f) Disconnect the engine wire from the 2 wire clamps.

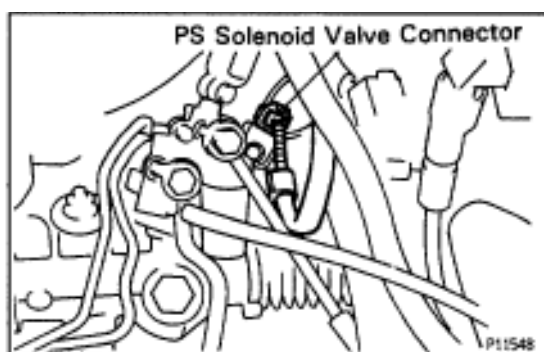

- (g) Disconnect the wire clamp and PS solenoid valve connector.

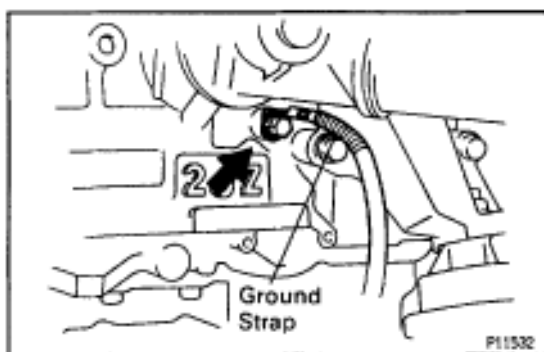

- (h) Remove the bolt, and disconnect the ground strap from the cylinder block.

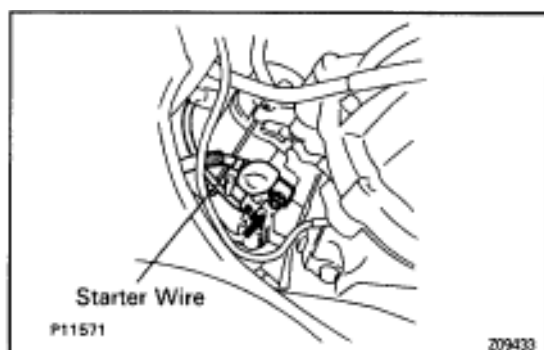

- (i) Remove the rubber cap and nut, and disconnect the starter wire.

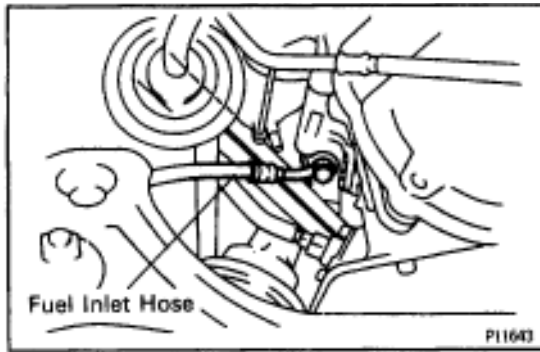

13. DISCONNECT FUEL HOSES

- (a) Remove the union bolt and 2 gaskets, disconnect the fuel inlet hose.

HINT:

- Put a suitable container or shop rag under the fuel pipe support.
- Slowly loosen the union bolt.

- (b) Suspend the hose union end upward.

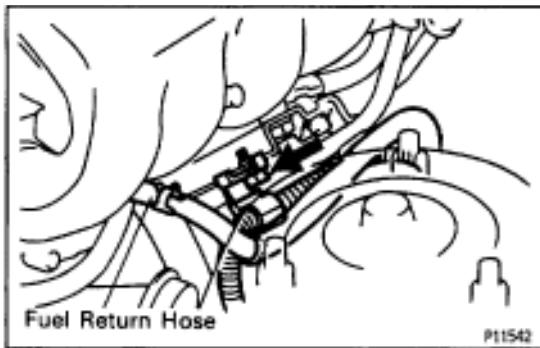

- (c) Disconnect the fuel return hose from the oil dipstick guide.
 (d) Disconnect the fuel return hose from the fuel return hose. Plug the hose end.

14. REMOVE ENGINE WIRE BRACKET

Remove the bolt and bracket, and disconnect the engine wire from the intake manifold stay.

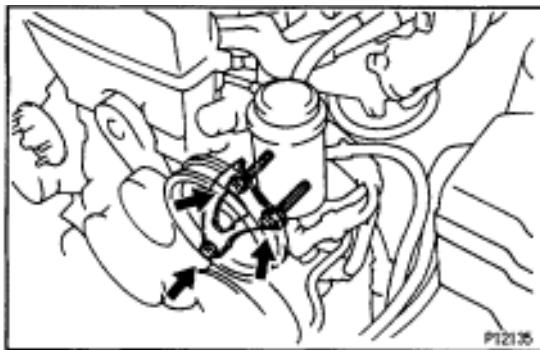

15. DISCONNECT PS PUMP WITHOUT DISCONNECTING HOSES

- (a) Remove the 3 bolts, plate washer and pump front bracket.

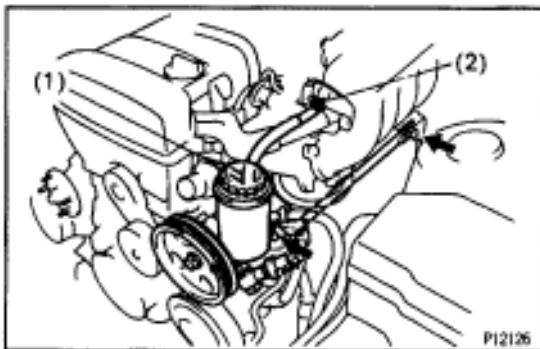

- (b) Disconnect these hoses:
 (1) Air hose from No.4 timing belt cover
 (2) Air hose from air intake chamber
 (c) Disconnect the pump housing from the pump bracket.
HINT: Put aside the pump housing, and suspend it.
 (d) Remove the 2 bolts and pump rear stay.

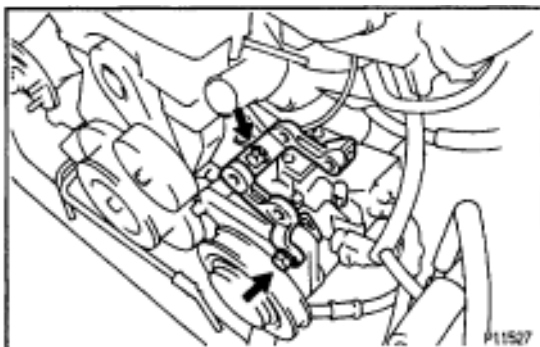

- (e) Remove the 2 bolts and pump bracket.

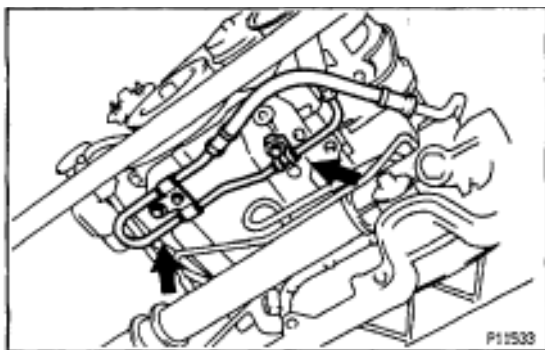
**16. DISCONNECT PS PRESSURE TUBE FROM ENGINE**

Remove the 2 clamp bolts, and disconnect the pressure tube.

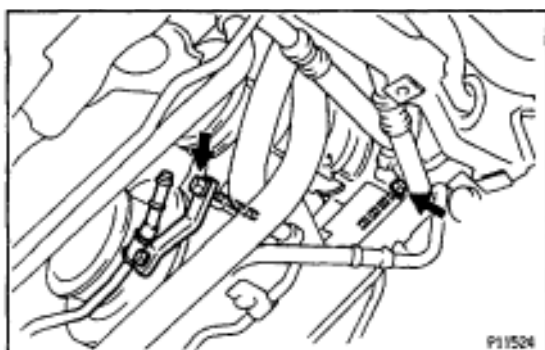
**17. DISCONNECT A/C COMPRESSOR WITHOUT DISCONNECTING HOSES**

(a) Remove the 2 bolts.

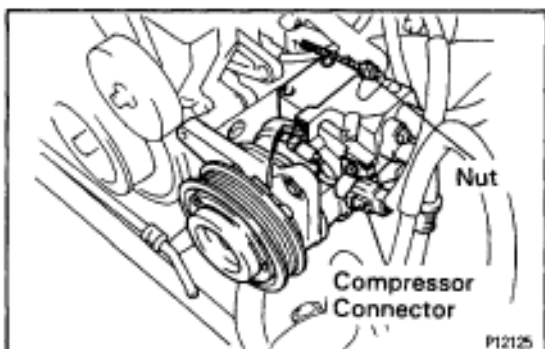

(b) Disconnect the compressor connector.

(c) Remove the nut.

(d) Using a torx socket (E10), remove the stud bolt, and disconnect the compressor from the engine.

HINT: Put aside the compressor, and suspend it securely.

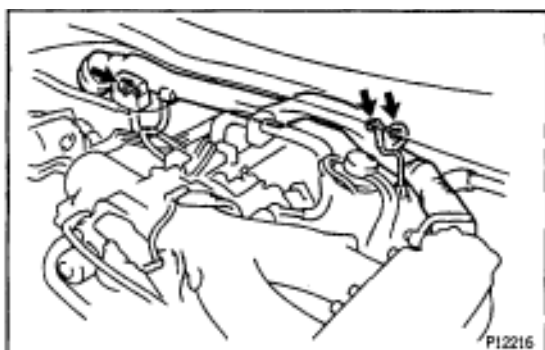
**18. DISCONNECT ENGINE WIRE FROM COWL PANEL**

(a) Remove the bolt, and disconnect the ground strap.

(b) Remove the 2 bolt, and disconnect the engine wire protector.

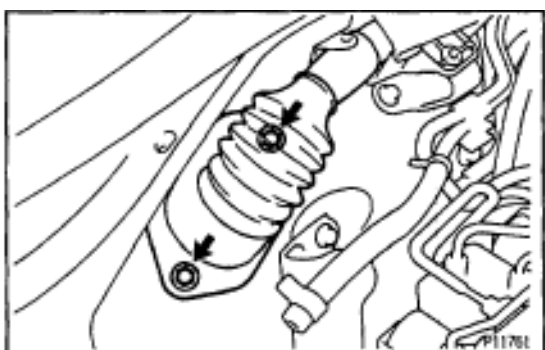

(c) Remove the 2 bolts holding the engine wire retainer to the cowl panel.

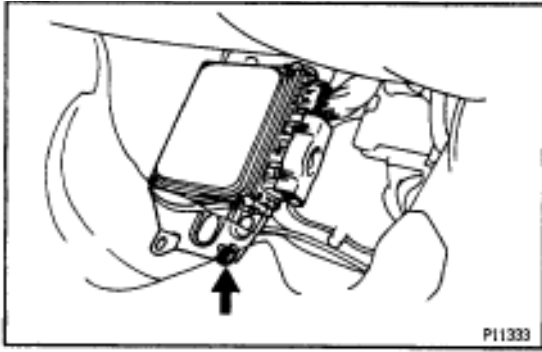

19. DISCONNECT ENGINE WIRE FROM CABIN

- (a) Remove the scuff plate.
- (b) Take out the front side of the floor carpet.
- (c) Remove the 2 nuts and ECM protector.
- (d) Remove the nut, and disconnect the ECM from the floor panel.

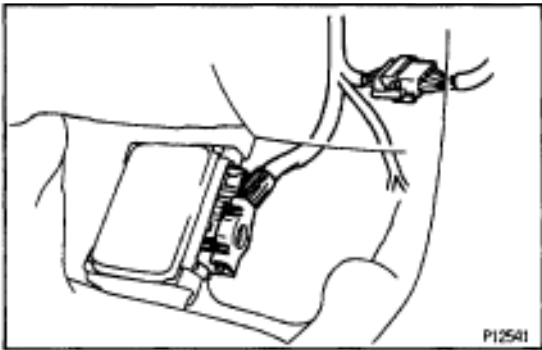

- (e) Disconnect the 2 connectors from the ECM.
- (f) Disconnect the connector from the instrument panel wire.



- (g) Disconnect the connector from the connector cassette.

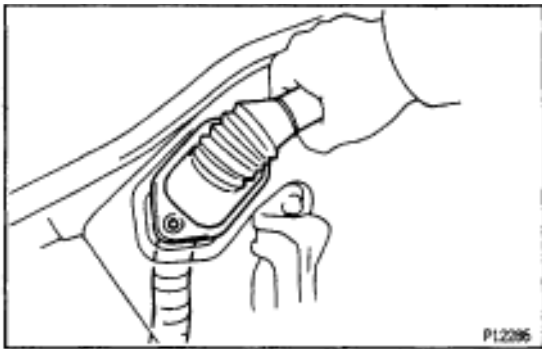

- (h) Pull out the engine wire from the cabin.

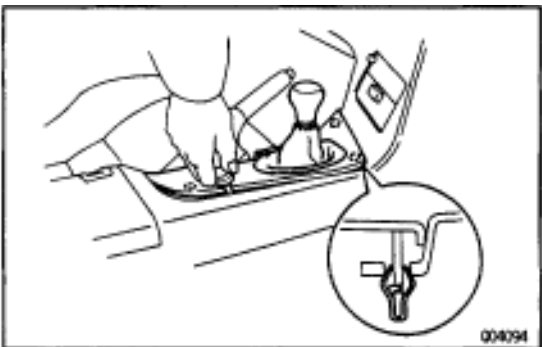

20. M/T:

REMOVE UPPER CONSOLE PANEL, SHIFT LEVER BOOTS AND HOLDING BOLTS

- (a) Remove the shift lever knob.
- (b) Using a screwdriver, pry out the upper console panel.

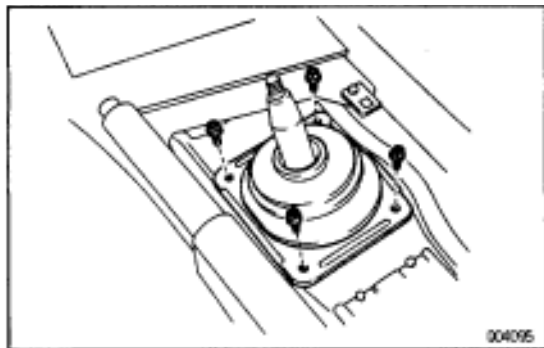

- (c) Remove the 4 bolts holding the lever boot to the transmission cover.
- (d) Remove the shift and select lever boots.

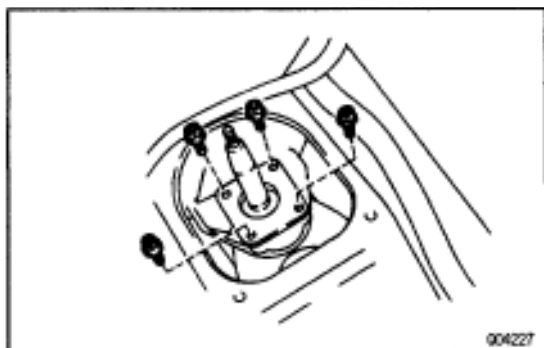

- (e) Remove the 4 bolts holding the shift lever to the shift lever retainer.

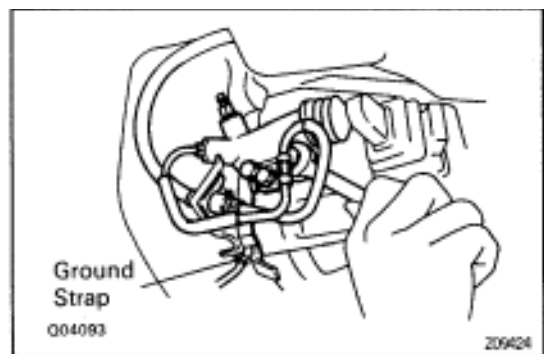

**21. M/T:
DISCONNECT CLUTCH RELEASE CYLINDER AND
GROUND STRAP FROM TRANSMISSION**

- (a) Remove the 2 bolts and clutch release cylinder.
- (b) Remove the bolt, and disconnect the ground strap.

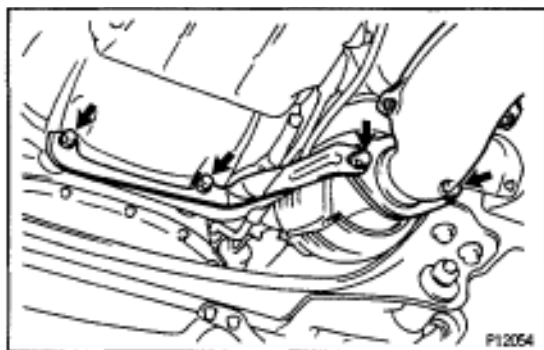

22. REMOVE NO.2 EXHAUST PIPE

- (a) Remove the 2 bolts and nuts holding the No.2 front exhaust pipe to the front exhaust pipe.
- (b) Remove the 2 bolts and pipe support bracket.
- (c) Remove the gasket, and disconnect the front exhaust pipe.

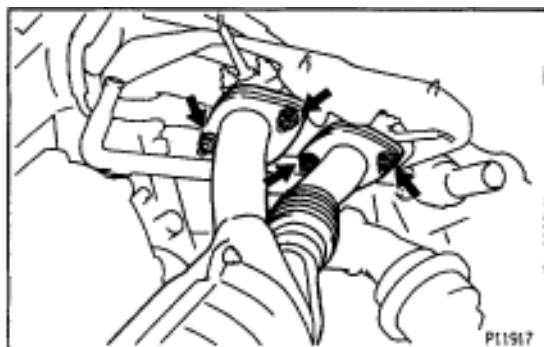

- (d) Remove the 4 nuts, No.2 front exhaust pipe and 2 gaskets.

23. REMOVE EXHAUST PIPE HEAT INSULATOR

24. REMOVE PROPELLER SHAFT

(See propeller shaft removal in Propeller Shaft)

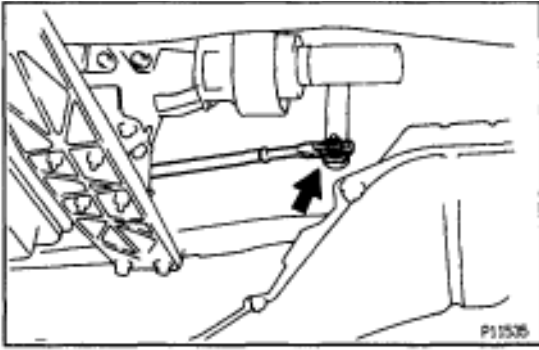

- 25. A/T:**
DISCONNECT TRANSMISSION CONTROL ROD
 Remove the nut, and disconnect the control rod from the shift lever.

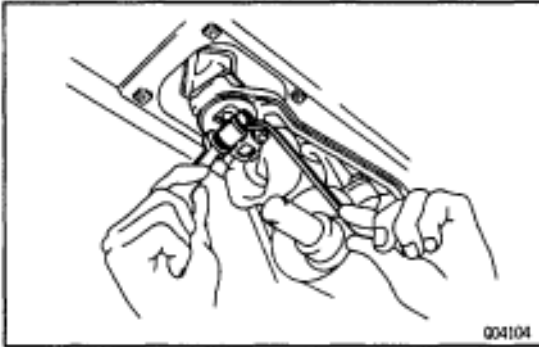

- 26. M/T:**
REMOVE TRANSMISSION SHIFT LEVER
 (a) Remove the bolt and nut.
 (b) Remove the transmission shift lever, inside of vehicle.

- 27. PLACE JACK UNDER TRANSMISSION**
NOTICE (A/T): Be sure to put a wooden block between the jack and the transmission oil pan to prevent damage.

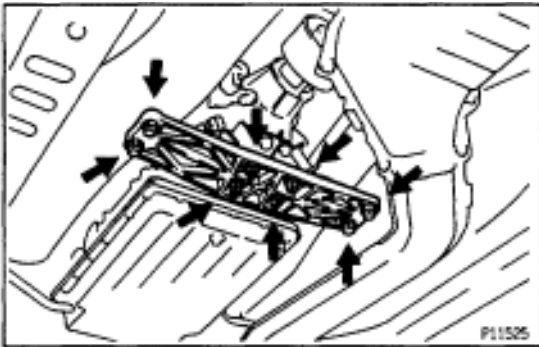

- 28. REMOVE REAR SUPPORT MEMBER**
 (a) Remove the 4 nuts holding the member to the engine rear mounting insulator.
 (b) Remove the 4 bolts and rear support member.

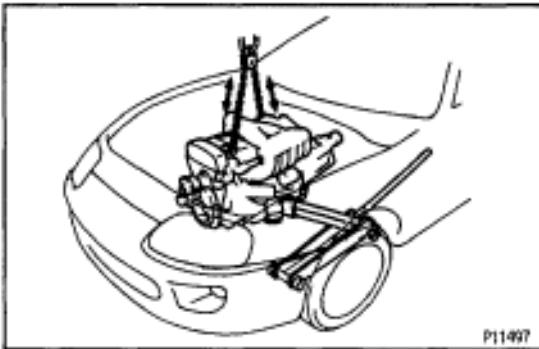

- 29. REMOVE ENGINE AND TRANSMISSION ASSEMBLY FROM VEHICLE**
 (a) Attach the engine hoist chain to the 2 engine hangers.

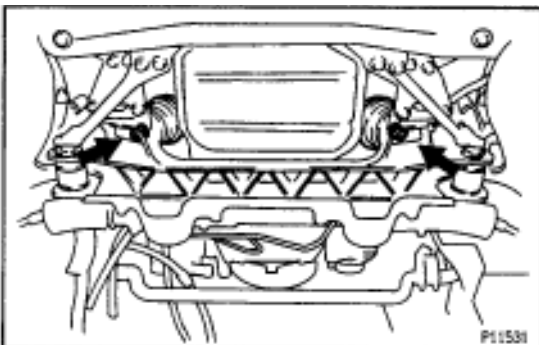

- (b) Remove the 2 nuts holding the engine front mounting insulators to the front suspension crossmember.

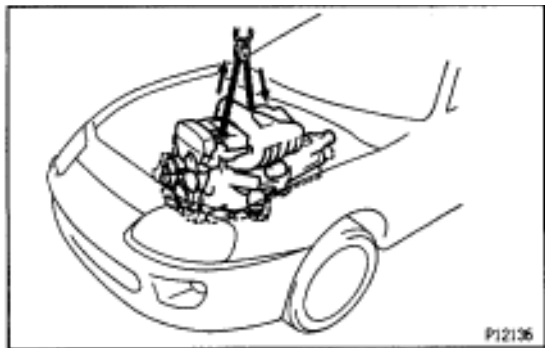

- (c) Lift the engine out of the vehicle slowly and carefully.
NOTICE: Remove the engine and transmission assembly carefully without damaging the shift lever retainer (M/ T), A/C compressor or PS solenoid valve.
- (d) Make sure the engine is clear of all wiring, hoses and cables.
- (e) Place the engine and transmission assembly onto the stand.

ENGINE REMOVAL (2JZ-GTE)

1. REMOVE HOOD
2. REMOVE RADIATOR ASSEMBLY
(See radiator removal in Cooling System)
3. DRAIN ENGINE OIL
4. DRAIN FUEL FROM FUEL TANK
5. REMOVE NO.1 AIR HOSE
6. DISCONNECT CONTROL CABLES FROM THROTTLE BODY

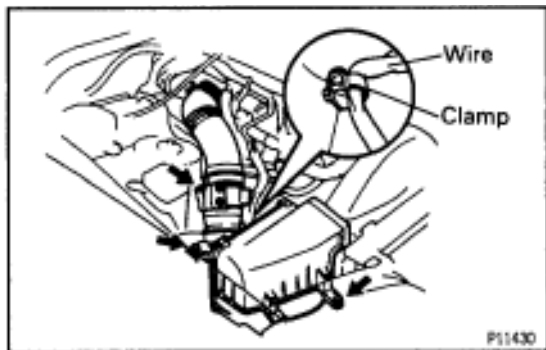

Disconnect these cables:

- Accelerator cable
- Cruise control actuator cable

7. REMOVE AIR CLEANER AND MAF METER ASSEMBLY
 - (a) Remove the 3 bolts.
 - (b) Loosen the hose clamp, disconnect the air hose from the intake air connector.
 - (c) Disconnect the MAF meter wire from the clamp on the air cleaner case.
 - (d) Disconnect the MAF meter connector, and remove the air cleaner and MAF meter assembly.
8. M/T:
REMOVE DRIVE BELT TENSIONER DAMPER
(See step 2 in timing belt removal)
9. REMOVE DRIVE BELT, FAN, FLUID COUPLING ASSEMBLY AND WATER PUMP PULLEY
(See step 6 in water pump removal in Cooling System)
10. REMOVE CHARCOAL CANISTER
11. DISCONNECT HEATER WATER HOSES
12. DISCONNECT BRAKE BOOSTER VACUUM HOSE
13. DISCONNECT EVAP HOSE

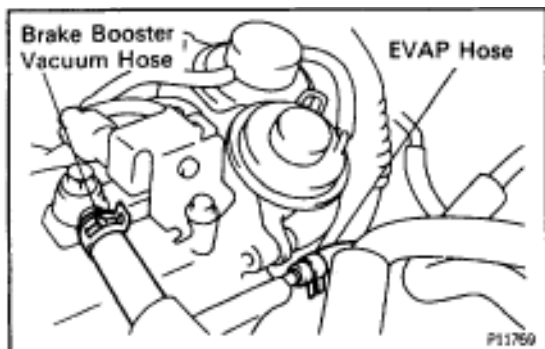

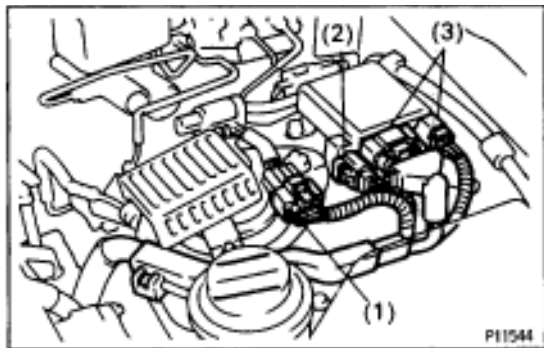

14. DISCONNECT WIRES AND CONNECTORS

- (a) Disconnect these connectors:
 - (1) Solenoid resistor connector
 - (2) Noise filter connector
 - (3) Igniter connectors
- (b) Disconnect the engine wire from the PS reservoir tank protector.

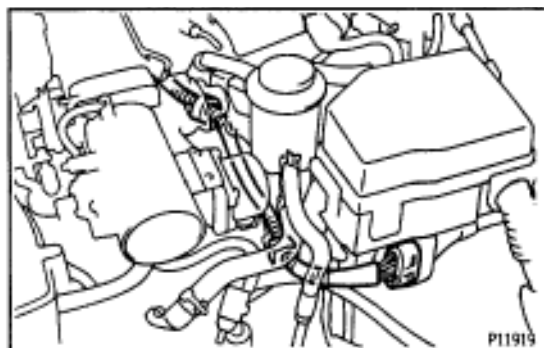

- (c) Disconnect the connector from the engine room main wire.
- (d) Disconnect the engine wire from the 2 wire clamps.

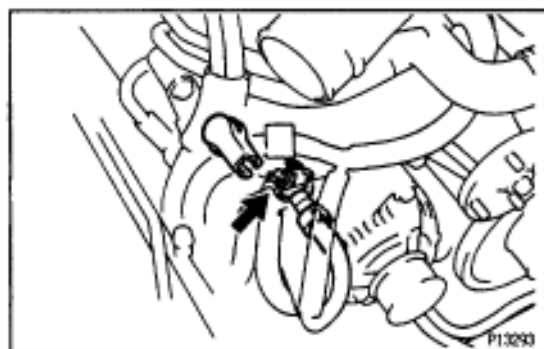

- (e) Remove the rubber cap and nut, and disconnect the generator wire.

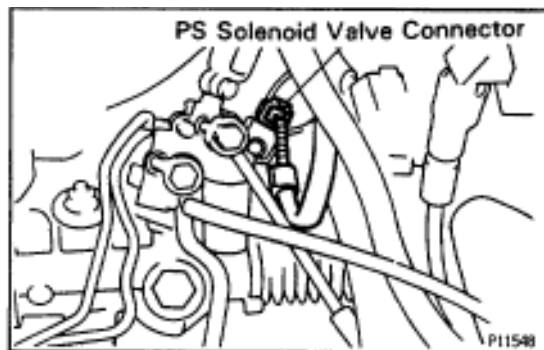

- (f) Disconnect the wire clamp and PS solenoid valve connector.

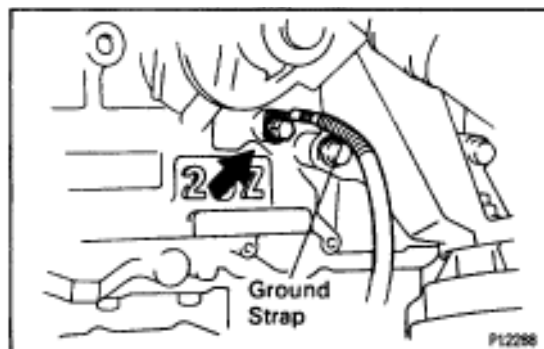

- (g) Remove the bolt and disconnect the ground strap from the cylinder block.

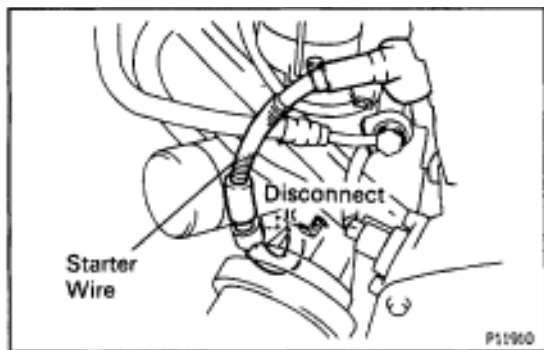

- (h) Disconnect the starter wire from the LH engine mounting bracket.
- (i) Remove the rubber cap and nut, and disconnect the starter wire.

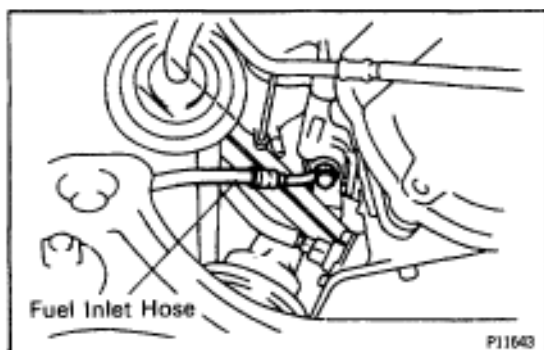

15. DISCONNECT FUEL HOSES

- (a) Remove the union bolt and 2 gaskets, and disconnect the fuel inlet hose.

HINT:

- Put a suitable container or shop rag under the fuel pipe support.
 - Slowly loosen the union bolt.
- (b) Suspend the hose union end upward.

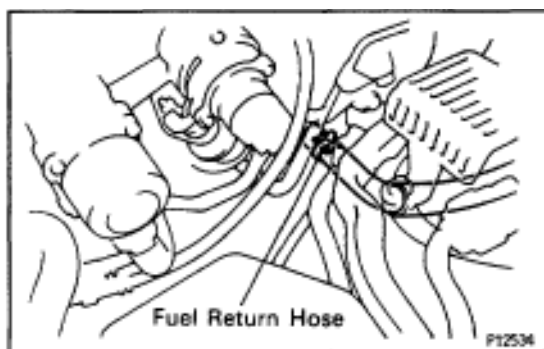

- (c) Disconnect the fuel return hose from the clamp of the dipstick guide.
- (d) Disconnect the fuel return hose from the fuel return pipe. Plug the hose end.

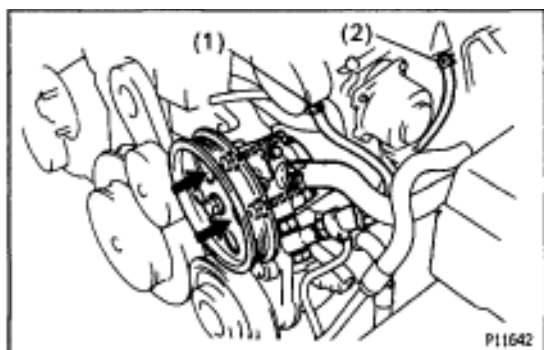

16. DISCONNECT PS PUMP WITHOUT DISCONNECTING HOSES

- (a) Disconnect these hoses:
 - (1) Air hose from throttle body
 - (2) Air hose from air intake chamber
- (b) Remove the 2 bolts, and disconnect the pump housing from the pump bracket.

HINT: Put aside the pump housing, and suspend it securely.

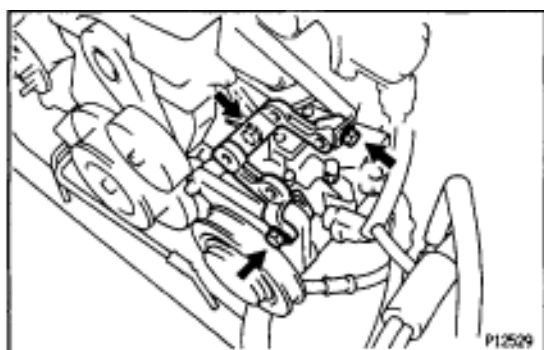

- (c) Remove the 3 bolts and pump bracket.

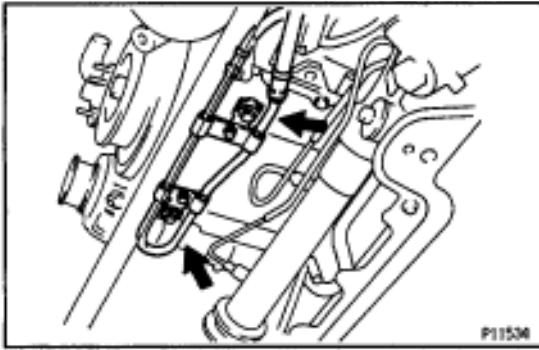

- 17. DISCONNECT PS PRESSURE TUBE FROM ENGINE**
Remove the 2 clamp bolts and disconnect the pressure tube.

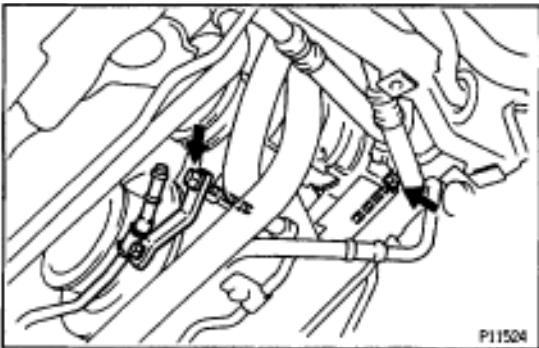

- 18. DISCONNECT A/C COMPRESSOR WITHOUT DISCONNECTING HOSES**

(a) Remove the 2 bolts.

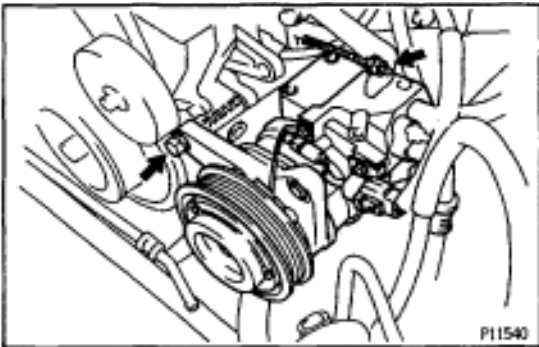

(b) Disconnect the compressor connector.

(c) Remove the bolt and nut.

(d) Using a torx socket (E10), remove the stud bolt, and disconnect the compressor from the engine.

HINT: Put aside the compressor, and suspend it securely.

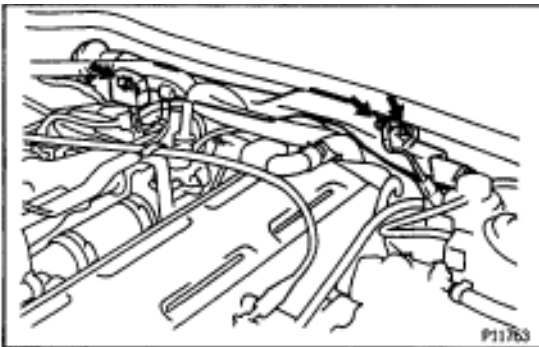

- 19. DISCONNECT ENGINE WIRE FROM COWL PANEL**

(a) Remove the bolt, and disconnect the ground strap.

(b) Remove the 2 bolts, and disconnect the engine wire protector.

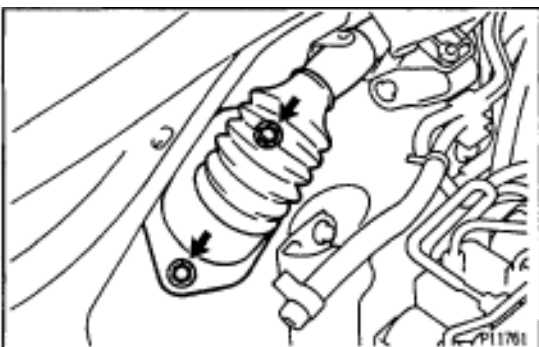

(c) Remove the 2 bolts holding the engine wire retainer to the cowl panel.

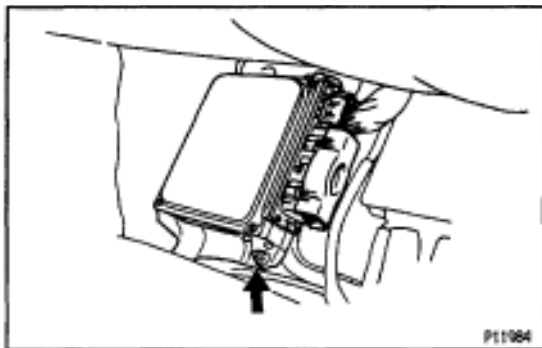
**20. DISCONNECT ENGINE WIRE FROM CABIN**

- (a) Remove the scuff plate.
- (b) Take out the front side of the floor carpet.
- (c) Remove the 2 nuts and ECM protector.
- (d) Remove the nut, and disconnect the ECM from the floor panel.

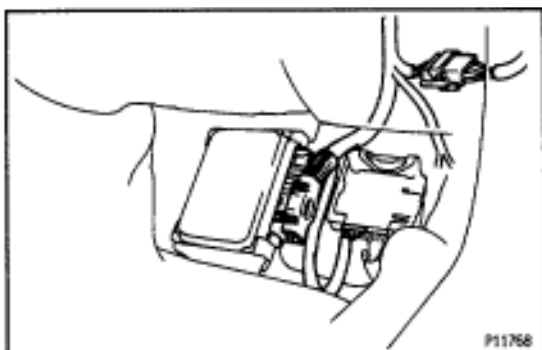

- (e) Disconnect the 2 connectors from the ECM.
- (f) Disconnect the connector from the TRAC ECU.
- (g) Disconnect the connector from the instrument panel wire.

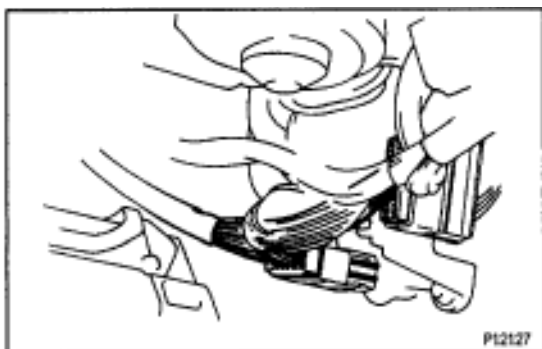

- (h) Disconnect the connectors from the connector cassette.

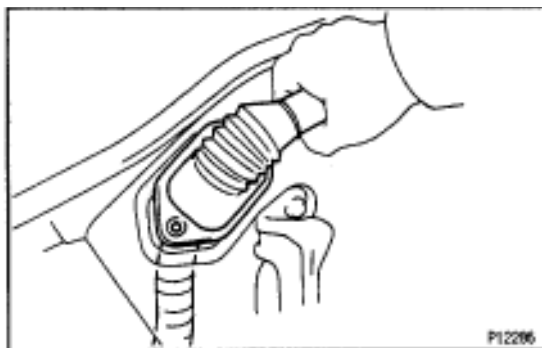

- (i) Pull out the engine wire from the cabin.

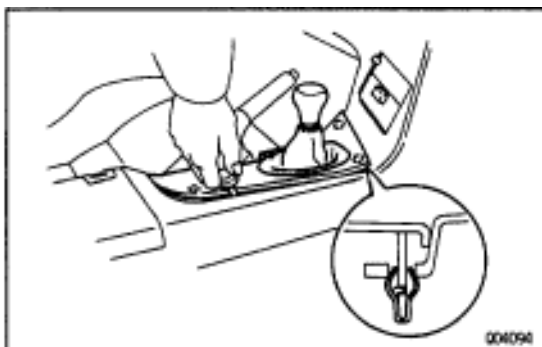
**21. M/T:
REMOVE UPPER CONSOLE PANEL, SHIFT LEVER
BOOTS AND HOLDING BOLTS**

- (a) Remove the shift lever knob.
- (b) Using a screwdriver, pry out the upper console panel.

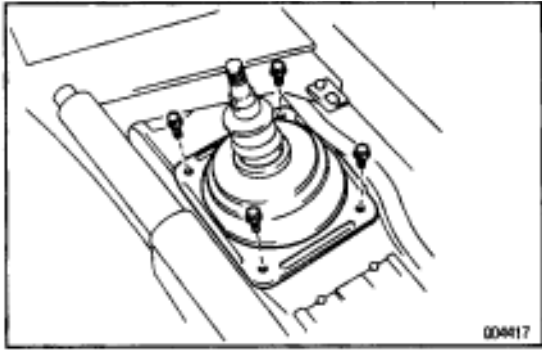

- (c) Remove the 4 bolts holding the lever boot to the transmission cover.
- (d) Remove the shift & select lever boots.

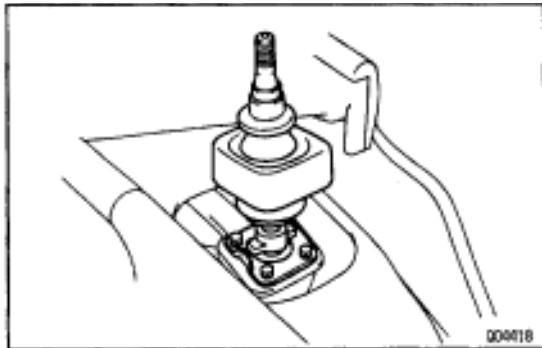

- (e) Remove the 4 bolts holding the shift lever to the shift lever retainer.

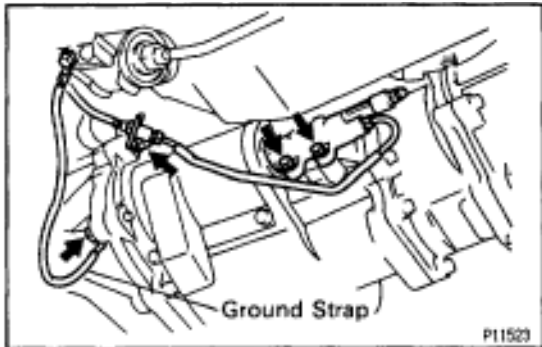

**22. M/T:
DISCONNECT CLUTCH RELEASE CYLINDER AND
GROUND STRAP FROM TRANSMISSION**

- (a) Remove the 2 bolts, and disconnect clutch release cylinder.
- (b) Remove the bolt, and disconnect the clutch line tube.
- (c) Remove the bolt, and disconnect ground strap.

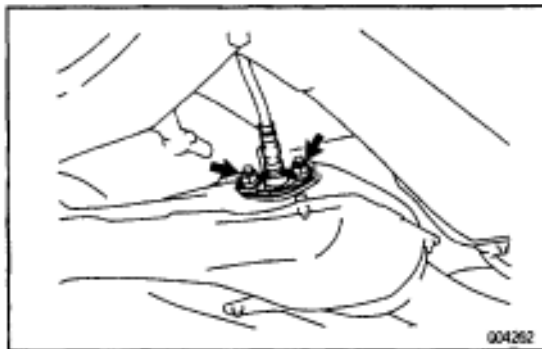

**23. DISCONNECT SUB HEATED OXYGEN SENSOR FROM
FRONT EXHAUST PIPE**

Remove the 2 nuts and sensor cover, and disconnect oxygen sensor and gasket.

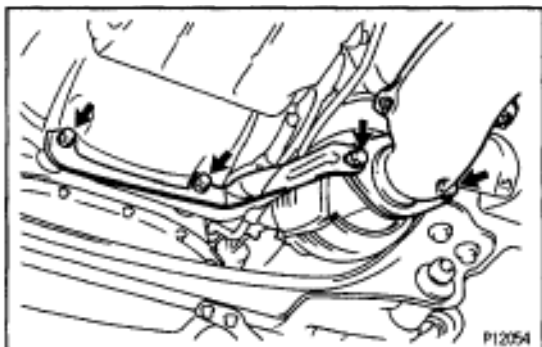

24. REMOVE EXHAUST PIPE ASSEMBLY

- (a) Remove the 2 bolts and nuts holding the front exhaust pipe to the No.2 front exhaust pipe.
- (b) Remove the 2 bolts and pipe support bracket.
- (c) Remove the gasket, and disconnect the front exhaust pipe.

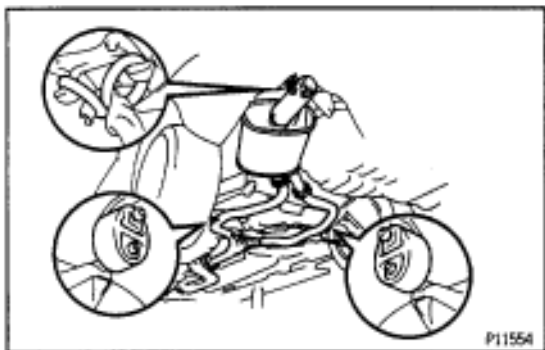

- (d) Disconnect the hook of the tailpipe from the 2 rings.
- (e) Disconnect the 2 rings on the exhaust pipe from the exhaust pipe brackets, and remove the exhaust pipe assembly.



25. REMOVE NO.2 FRONT EXHAUST PIPE

Remove the 3 nuts, front exhaust pipe and gasket.

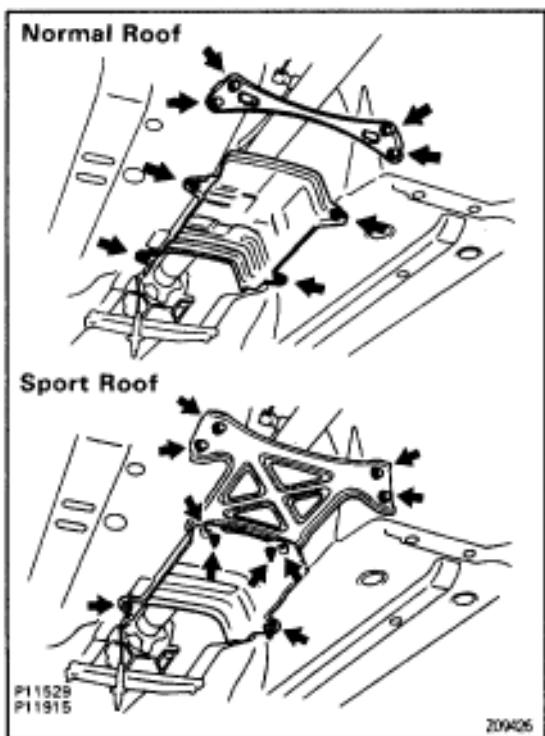

26. REMOVE EXHAUST PIPE HEAT INSULATOR

Remove the 4 nuts and heat insulator.

27. REMOVE REAR CENTER FLOOR CROSSMEMBER BRACE

Remove the 4 bolts (Normal roof) or 6 bolts (Sport Roof) and crossmember brace.

28. REMOVE PROPELLER SHAFT

(See propeller shaft removal in Propeller Shaft)



29. A/T:

DISCONNECT TRANSMISSION CONTROL ROD

Remove the nut, and disconnect the control rod from the shift lever.

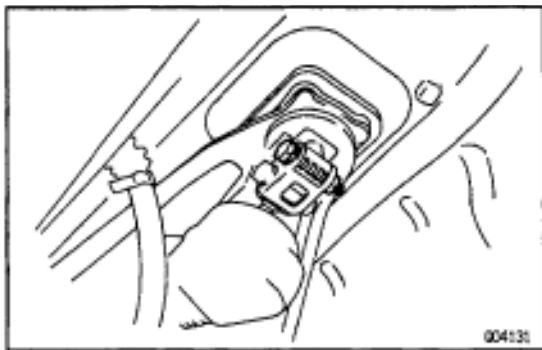

**30. M/T:
REMOVE TRANSMISSION SHIFT LEVER**

- (a) Remove the bolt and nut.
- (b) Remove the transmission shift lever, inside of vehicle.

31. PLACE JACK UNDER TRANSMISSION

NOTICE (A/T): Be sure to put a wooden block between the jack and the transmission oil pan to prevent damage.

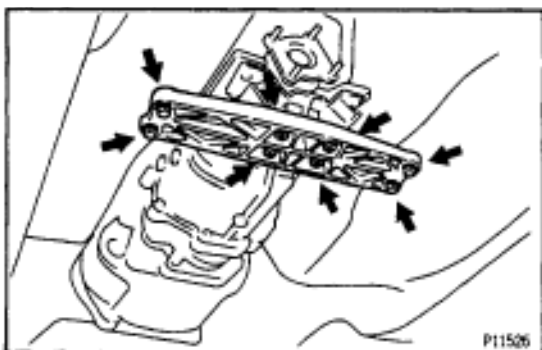

32. REMOVE REAR SUPPORT MEMBER

- (a) Remove the 4 nuts holding the member to the engine rear mounting insulator.
- (b) Remove the 4 bolts and rear support member.

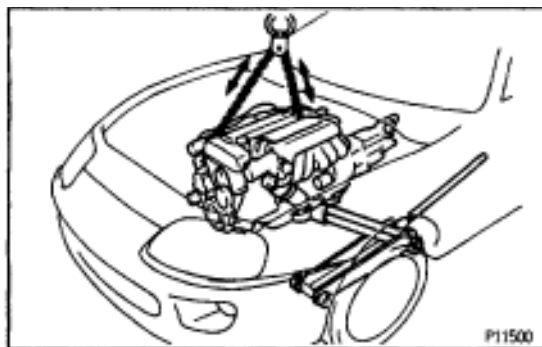

33. REMOVE ENGINE AND TRANSMISSION ASSEMBLY FROM VEHICLE

- (a) Attach the engine hoist chain to the 2 engine hangers.

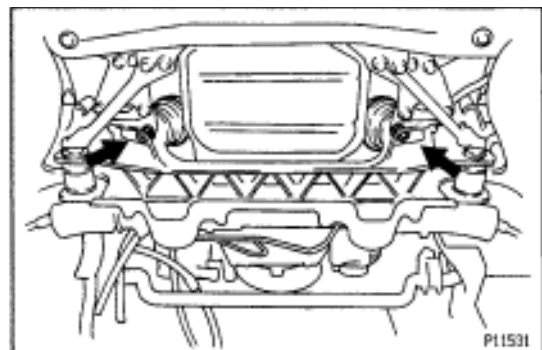

- (b) Remove the 2 nuts holding the engine front mounting insulators to the front suspension crossmember.

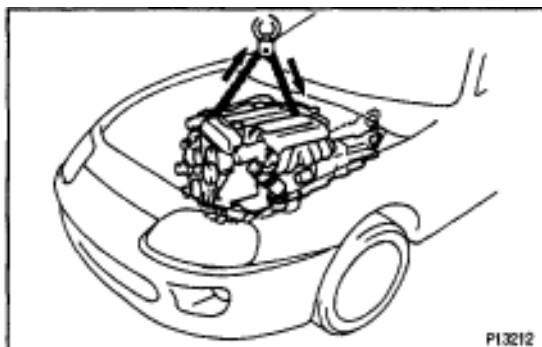

- (c) Lift the engine out of the vehicle slowly and carefully.
NOTICE: Remove the engine and transmission assembly carefully without damaging the shift lever retainer (M/ T), A/C compressor or PS solenoid valve
- (d) Make sure the engine is clear of all wiring, hoses and cables.
- (e) Place the engine and transmission assembly onto the stand.

COMPONENTS FOR ENGINE & TRANSMISSION SEPERATION AND ASSEMBLY

M/T 2JZ-GE

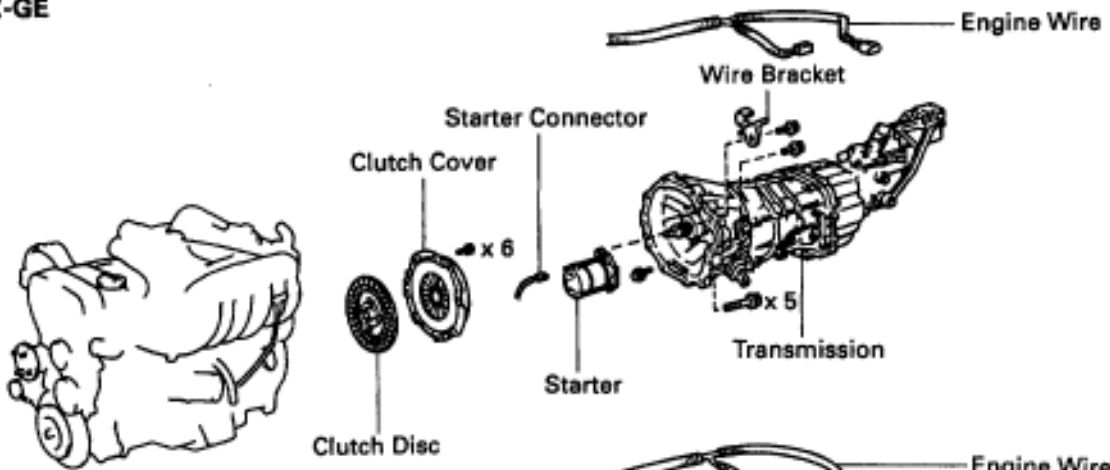

M/T 2JZ-GTE

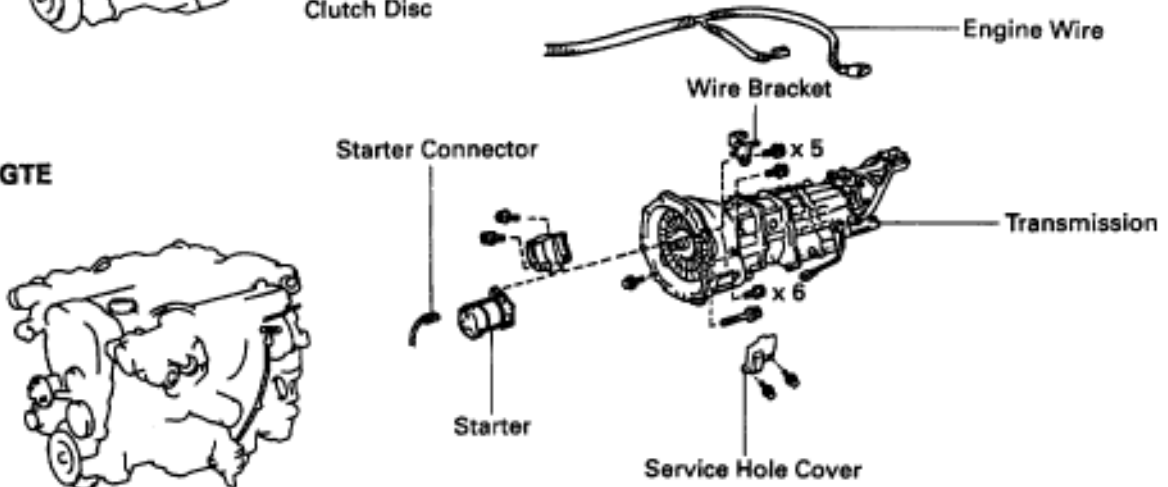

A/T

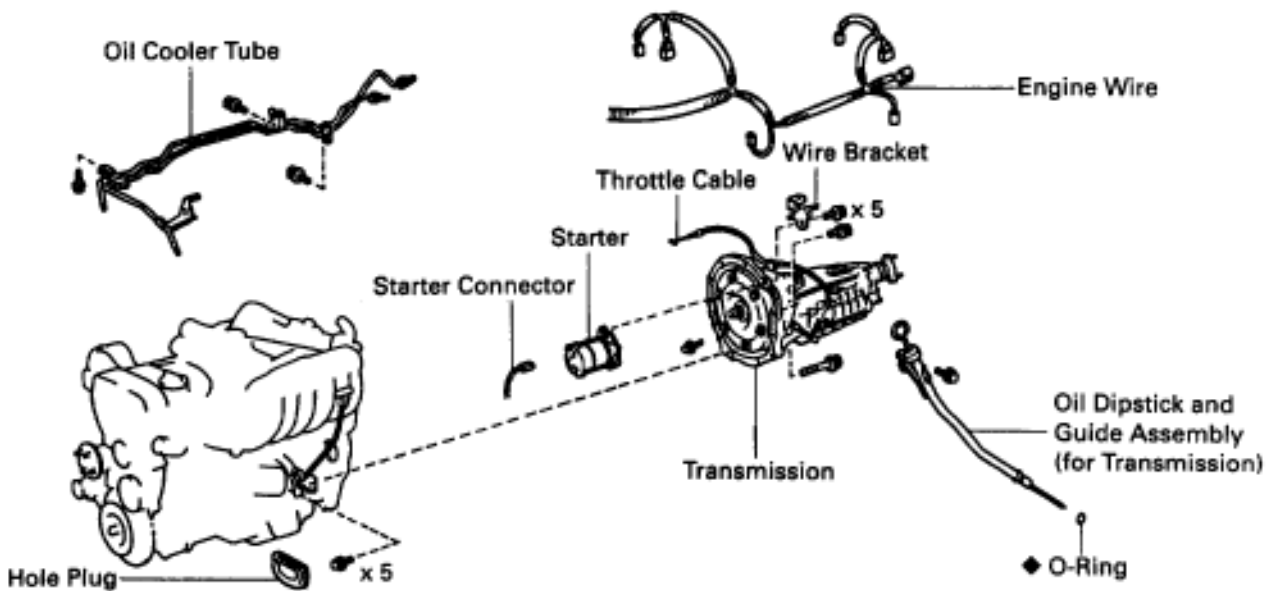

◆ Non-reusable part

ENGINE & TRANSMISSION SEPARATION

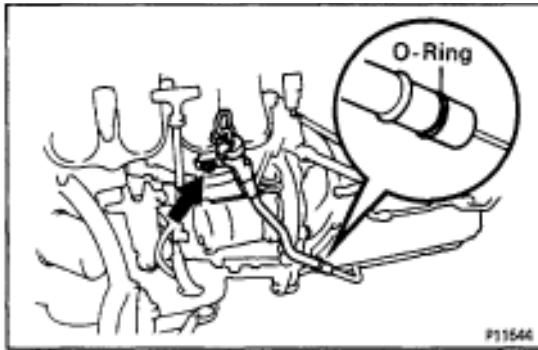

1. A/T: REMOVE OIL DIPSTICK GUIDE FOR TRANSMISSION

- (a) Remove the bolt.
- (b) Pull out the dipstick and guide from the transmission.
- (c) Remove the O-ring from the dipstick guide.

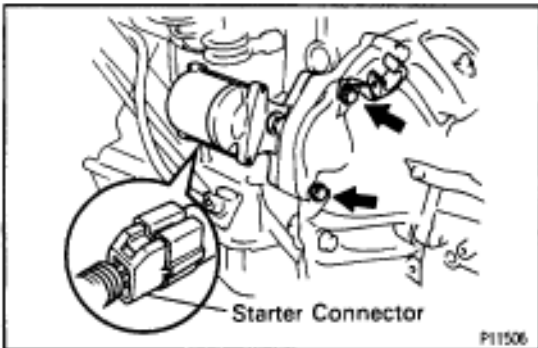

2. DISCONNECT ENGINE WIRE FROM TRANSMISSION

- (a) Disconnect the connectors.
- (b) Disconnect the wire clamps from the brackets.

3. REMOVE STARTER

- (a) Disconnect the starter connector.
- (b) Remove the 2 bolts, engine wire bracket and starter.

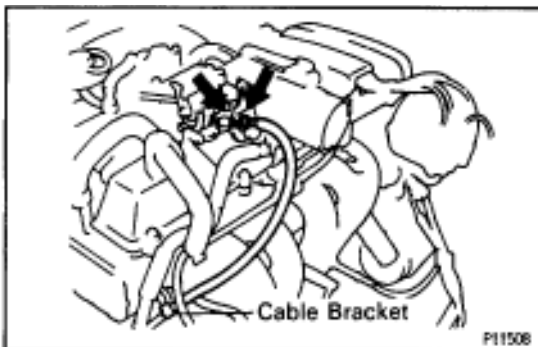

4. 2JZ-GE A/T: DISCONNECT THROTTLE CABLE

- (a) Disconnect the throttle cable from the throttle body.
- (b) Disconnect the throttle cable from the cable bracket on the cylinder head.

5. A/T:

REMOVE OIL COOLER TUBES FOR TRANSMISSION

- (a) Remove the 2 hose clamp bolts and tube clamp bolt.
- (b) Loosen the 2 union nuts, and remove the oil cooler tubes.

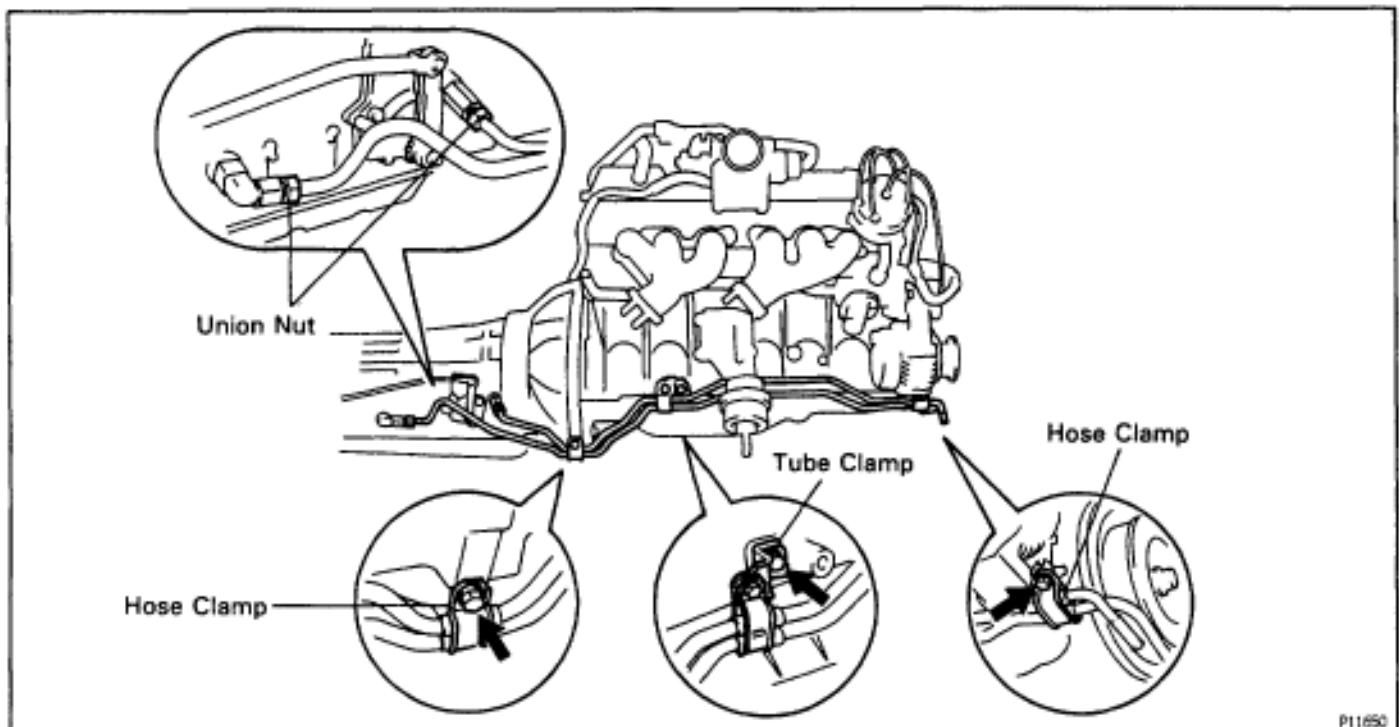

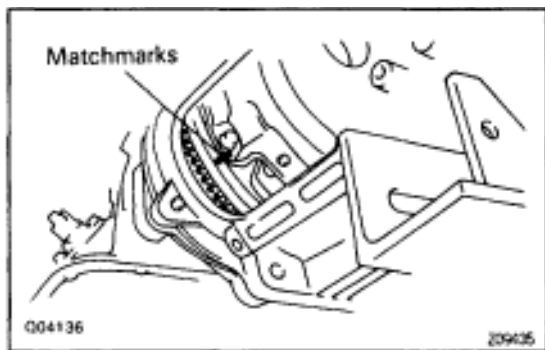
**6. 2JZ-GTE M/T:****REMOVE CLUTCH COVER SET BOLTS**

- (a) Remove the 2 bolts and service hole cover.
- (b) Place the matchmarks on the flywheel and clutch cover.
- (c) Remove the 6 bolts.

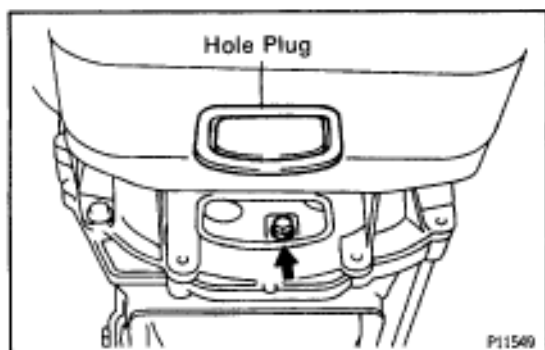
**7. A/T:****REMOVE TORQUE CONVERTER CLUTCH MOUNTING BOLTS**

- (a) Remove the hole plug.
- (b) Turn the crankshaft to gain access to each bolt. Remove the 6 bolts.

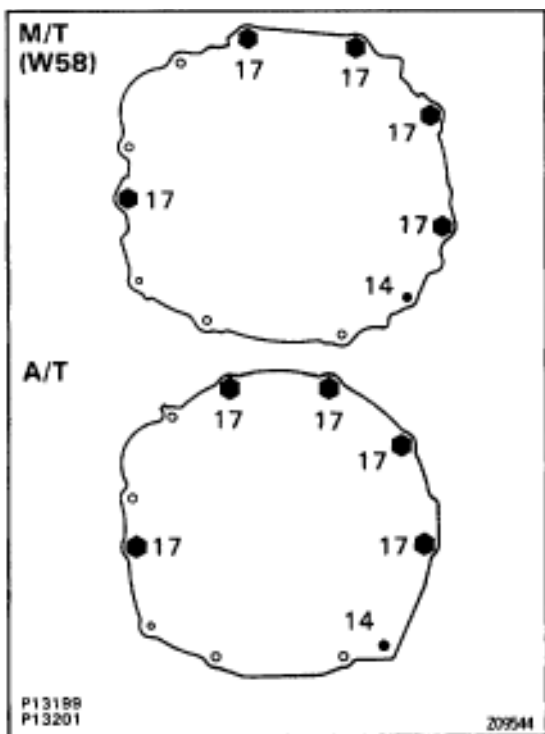
**8. SEPARATE ENGINE AND TRANSMISSION**

Remove the 6 bolts and transmission.

HINT: The "17" is 17 mm head bolt, and "14" is 14 mm head bolt.

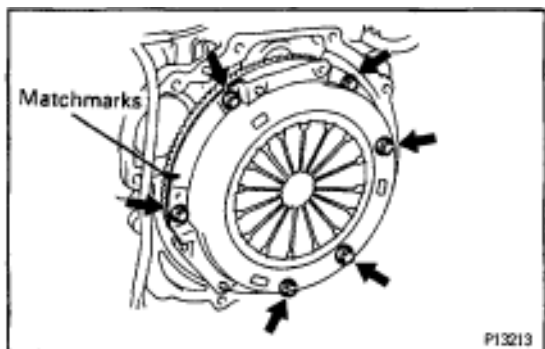
**9. 2JZ-GE M/T:****REMOVE CLUTCH COVER AND DISC**

- (a) Place matchmarks on the flywheel and clutch cover.
- (b) Loosen each bolt one turn at a time until spring tension is released.
- (c) Remove the bolts, and pull off the clutch cover with the clutch disc.

NOTICE: Do not drop the clutch disc.

COMPONENTS FOR CYLINDER BLOCK DISASSEMBLY AND ASSEMBLY

2JZ-GE

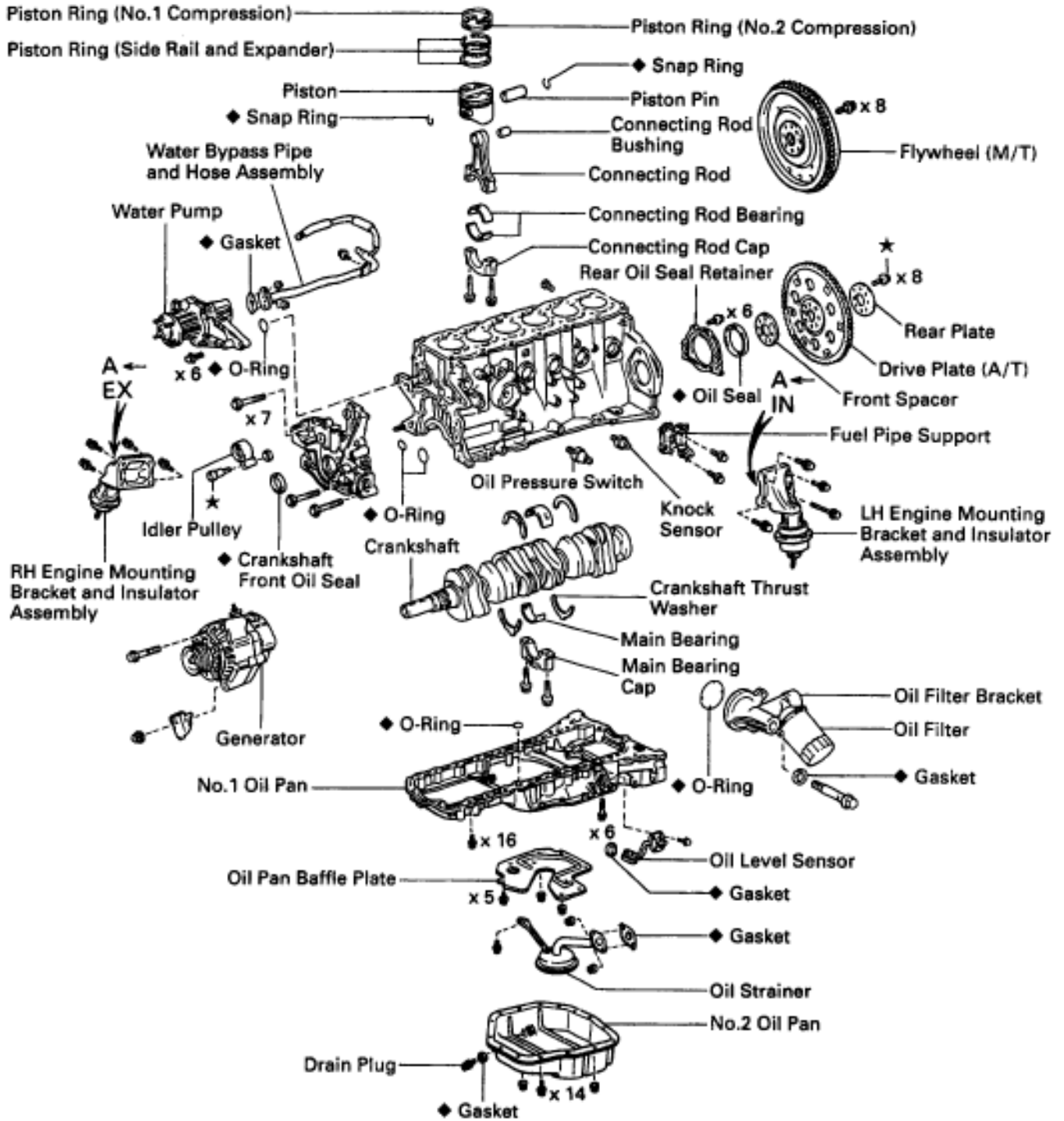

◆ Non-reusable part
 ★ Precoated part

2JZ-GTE

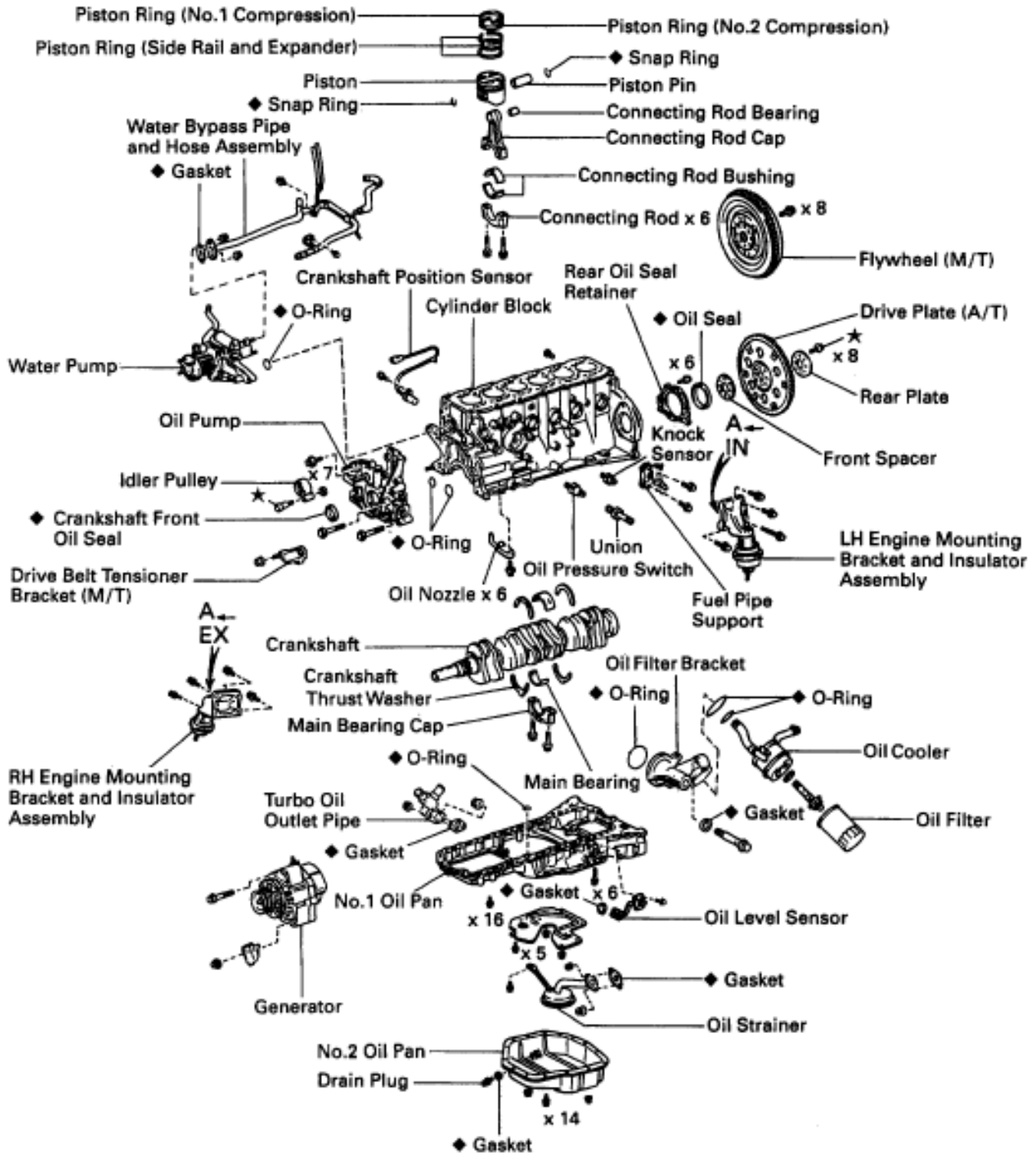

◆ Non-reusable part
 ★ Precoated part

PREPARATION FOR DISASSEMBLY

1. **M/T:**
REMOVE FLYWHEEL
2. **A/T:**
REMOVE DRIVE PLATE
3. **INSTALL ENGINE TO ENGINE STAND FOR DISASSEMBLY**
4. **REMOVE GENERATOR**
5. **REMOVE TIMING BELT AND PULLEYS**
(See timing belt removal)
6. **REMOVE CYLINDER HEAD**
(See cylinder head removal)
7. **REMOVE OIL FILTER**
(See oil and filter replacement in Lubrication System)
8. **2JZ-GTE:**
REMOVE OIL COOLER
(See oil cooler removal in Lubrication System)
9. **REMOVE NO.2 WATER BYPASS PIPE**
 - (a) **2JZ-GE:**
Remove the bolt, 2 nuts, water bypass pipe and gasket.
 - (b) **2JZ-GTE:**
Remove the 2 bolts, 2 nuts, water bypass pipe and gasket.

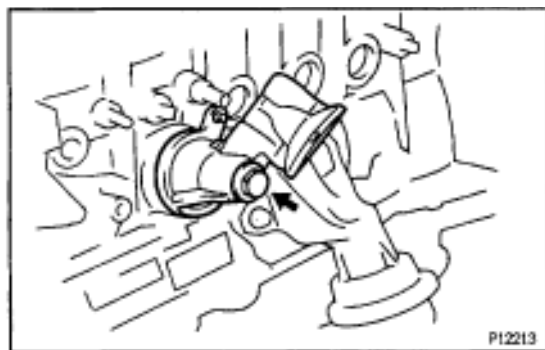
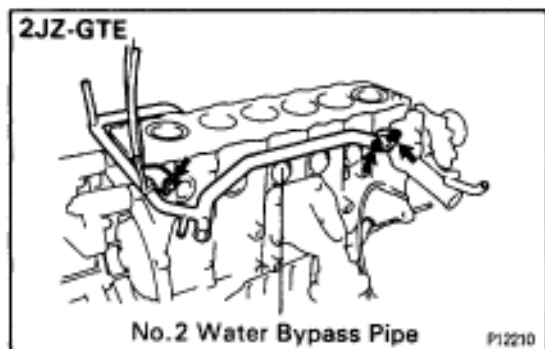
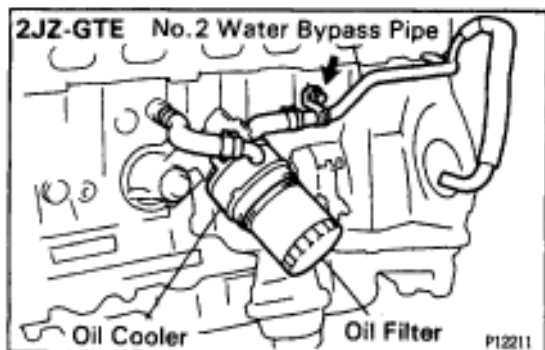

10. **REMOVE OIL FILTER BRACKET**
Remove the union bolt, gasket, oil filter bracket and O-ring.

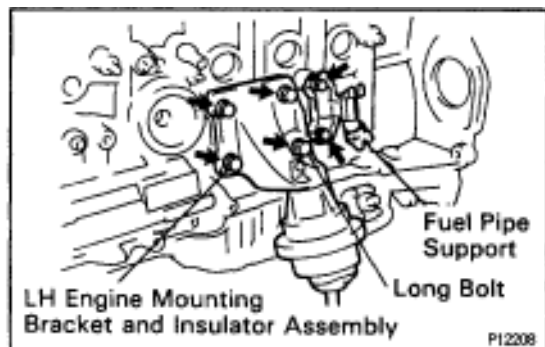

11. **REMOVE LH ENGINE MOUNTING BRACKET AND INSULATOR ASSEMBLY**
12. **REMOVE FUEL PIPE SUPPORT**

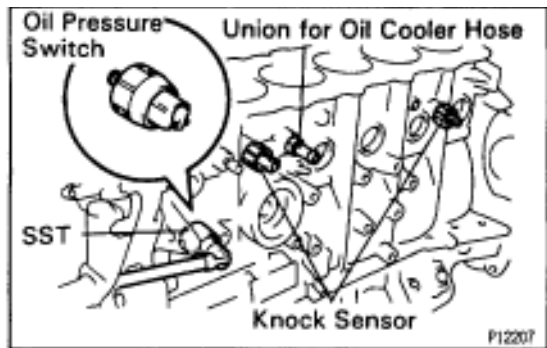

13. REMOVE OIL PRESSURE SWITCH AND KNOCK SENSORS

Using SST, remove the switch and sensors.
SST 09816-30010

14. 2JZ-GTE: REMOVE UNION FOR OIL COOLER HOSE

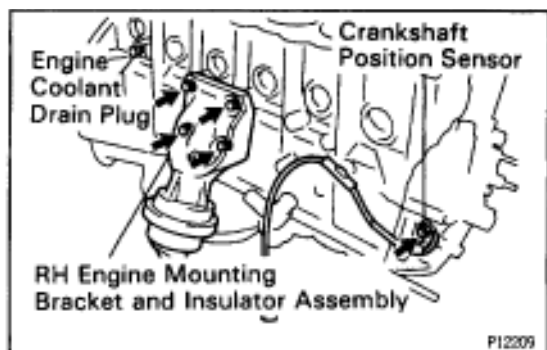

15. REMOVE ENGINE COOLANT DRAIN PLUG 16. REMOVE RH ENGINE MOUNTING BRACKET AND INSULATOR ASSEMBLY

17. 2JZ-GTE:
REMOVE CRANKSHAFT POSITION SENSOR
18. REMOVE WATER PUMP
(See water pump removal in Cooling System)
19. REMOVE OIL PUMP
(See oil pump removal in Lubrication System)

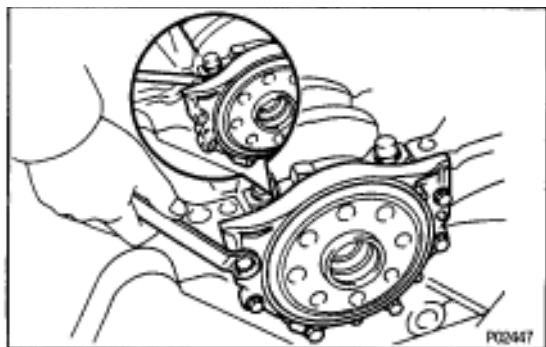

CYLINDER BLOCK DISASSEMBLY

1. REMOVE REAR OIL SEAL RETAINER

- Remove the 6 bolts.
- Remove the oil seal retainer by prying the area between the oil seal retainer and main bearing cap with a screwdriver.

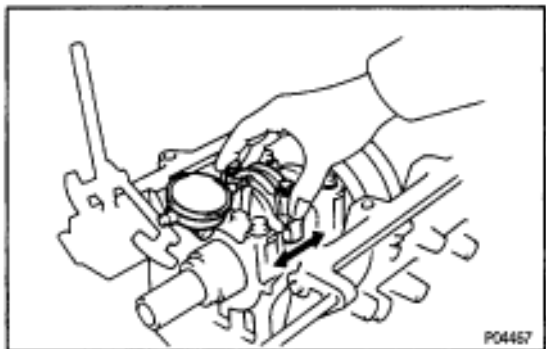

2. CHECK CONNECTING ROD THRUST CLEARANCE

Using a dial indicator, measure the thrust clearance while moving the connecting rods back and forth.

Standard thrust clearance:

0.250-0.402 mm (0.0098-0.0158 in.)

Maximum thrust clearance:

0.50 mm (0.0197 in.)

If the thrust clearance is greater than maximum, replace the connecting rod assembly(s). If necessary, replace the crankshaft.

Connecting rod thickness:

25.898-25.950 mm (1.0196-1.0217 in.)

3. REMOVE CONNECTING ROD CAPS AND CHECK OIL CLEARANCE

- Check the matchmarks on the connecting rod and cap to ensure correct reassembly.

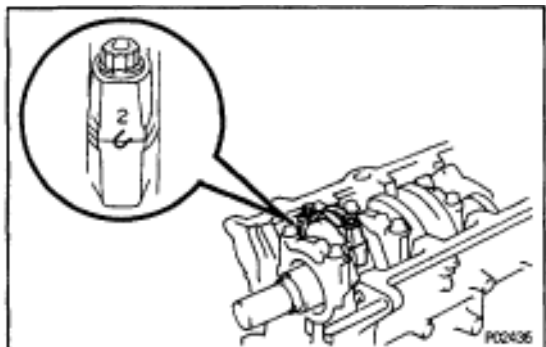

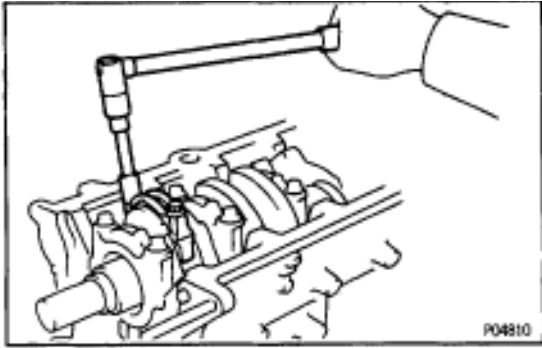

- (b) Remove the connecting rod cap bolts.

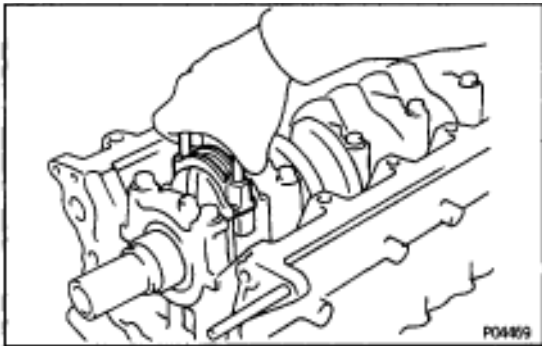

- (c) Using the 2 removed connecting rod bolts, remove the connecting rod cap and lower bearing by wiggling the connecting rod cap right and left.
HINT: Keep the lower bearing inserted with the connecting rod cap.

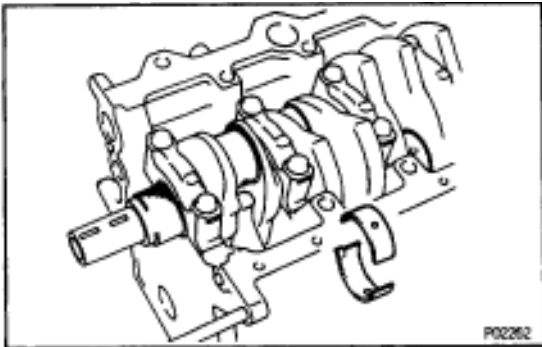

- (d) Clean the crank pin and bearings.
(e) Check the crank pin and bearing for pitting and scratches. If the crank pin or bearing is damaged, replace the bearings. If necessary, replace the crankshaft.

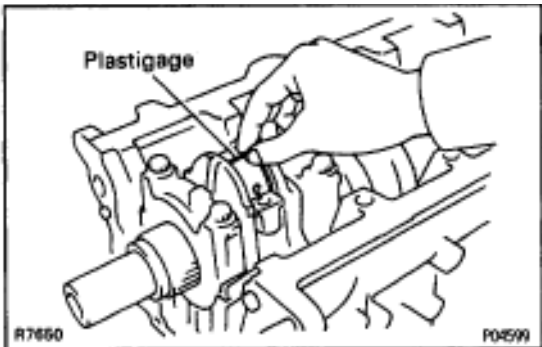

- (f) Lay a strip of Plastigage across the crank pin.

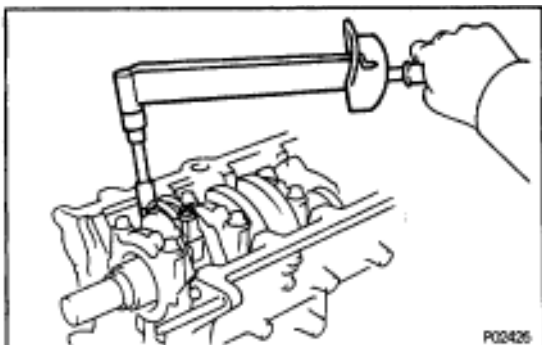

- (g) Install the connecting rod cap with the 2 bolts. (See step 8 in cylinder block assembly)

Torque:

1st

29 N·m (300 kgf·cm, 22 ft·lbf)

2nd

Turn 90°

NOTICE: Do not turn the crankshaft.

- (h) Remove the 2 bolts, connecting rod cap and lower bearing. (See procedure (b) and (c) above)

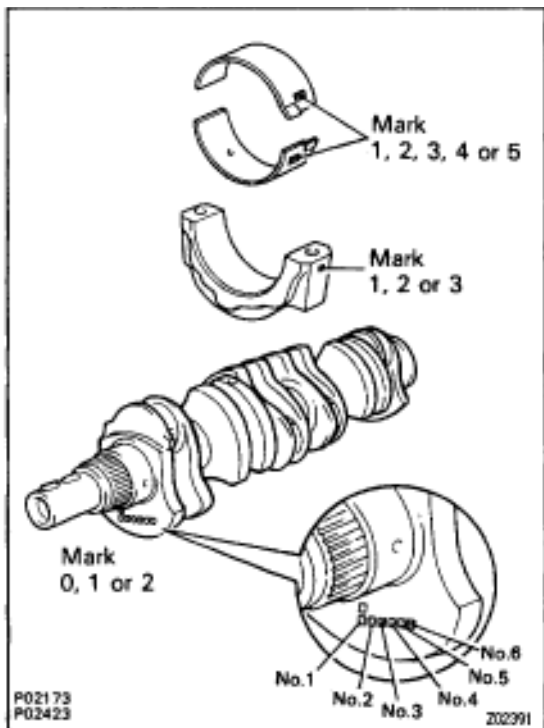
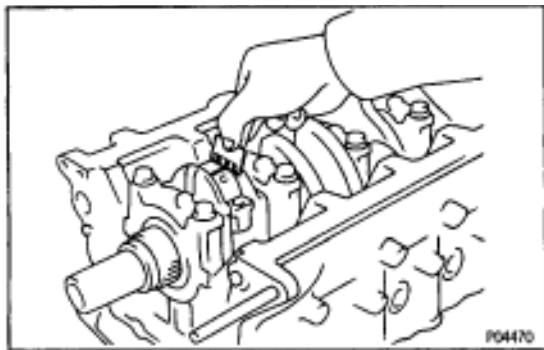

(i) Measure the Plastigage at its widest point.

Standard oil clearance:

STD

.035–0.053 mm (0.0014–0.0021 in.)

U/S 0.25

.040–0.078 mm (0.0016–0.0031 in.)

Maximum oil clearance.

STD

.08 mm (0.0031 in.)

U/S 0.25

.09 mm (0.0035 in.)

If the oil clearance is greater than maximum, replace the bearings. If necessary, grind or replace the crankshaft.

HINT: If using a standard bearing, replace with one having the same number. If the number of the bearing cannot be determined, select the correct bearing by adding together the numbers imprinted on the connecting rod cap and crankshaft, then selecting the bearing with the same number as the total. There are 5 sizes of standard bearings, marked "1", "2", "3", "4" and "5" accordingly.

	Number mark								
	1			2			3		
Connecting rod cap									
Crankshaft	0	1	2	0	1	2	0	1	2
Use bearing	1	2	3	2	3	4	3	4	5

EXAMPLE: Connecting rod cap "3" +Crankshaft "1" = Total number 4 (Use bearing "4")

Reference:

Connecting rod big end inside diameter:

Mark "1"

55.025–55.031 mm (2.1663–2.1666 in.)

Mark "2"

55.031–55.037 mm (2.1666–2.1668 in.)

Mark "3"

55.037–55.043 mm (2.1668–2.1670 in.)

Crankshaft crank pin diameter:

Mark "0"

51.994–52.000 mm (2.0470–2.0472 in.)

Mark "1"

51.988–51.994 mm (2.0468–2.0470 in.)

Mark "2"

51.982–51.988 mm (2.0465–2.0468 in.)

Bearing center wall thickness:**Mark "1"**

1.492–1.495 mm (0.0587–0.0589 in.)

Mark "2"

1.495–1.498 mm (0.0589–0.0590 in.)

Mark "3"

1.498–1.501 mm (0.0590–0.0591 in.)

Mark "4"

1.501–1.504 mm (0.0591–0.0592 in.)

Mark "5"

1.504–1.507 mm (0.0592–0.0593 in.)

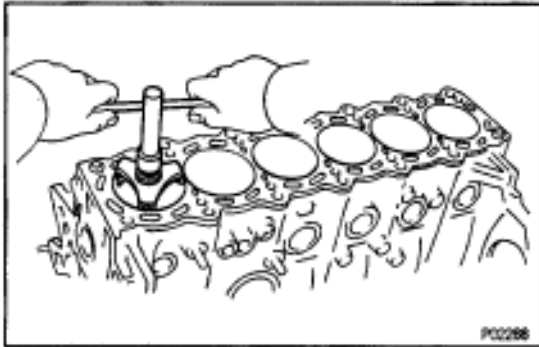

- (j) Completely remove the Plastigage.

4. REMOVE PISTON AND CONNECTING ROD ASSEMBLIES

- (a) Using a ridge reamer, remove all the carbon from the top of the cylinder.
- (b) Push the piston, connecting rod assembly and upper bearing through the top of the cylinder block.

HINT:

- Keep the bearings, connecting rod and cap together.
- Arrange the piston and connecting rod assemblies in correct order.

5. CHECK CRANKSHAFT THRUST CLEARANCE

Using a dial indicator, measure the thrust clearance while prying the crankshaft back and forth with a screwdriver.

Standard thrust clearance:

0.020–0.220 mm (0.0008–0.0087 in.)

Maximum thrust clearance:

0.30 mm (0.0118 in.)

If the thrust clearance is greater than maximum, replace the thrust washers as a set.

Thrust washer thickness:

1.940–1.990 mm (0.0764–0.0783 in.)

6. REMOVE MAIN BEARING CAPS AND CHECK OIL CLEARANCE

- (a) Uniformly loosen and remove the 14 main bearing cap bolts, in several passes, in the sequence shown.

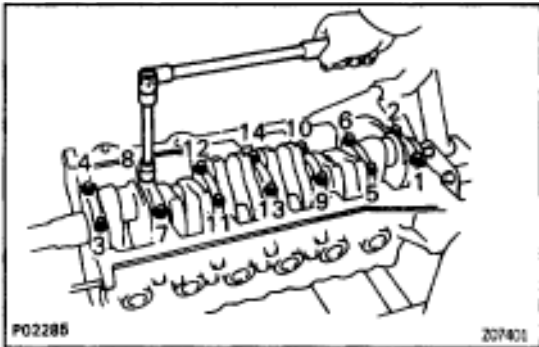

- (b) Using the removed main bearing cap bolts, pry the main bearing cap back and forth, and remove the main bearing caps, lower bearings and lower thrust washers (No.4 main bearing cap only).

HINT:

- Keep the lower bearing and main bearing cap together.
- Arrange the main bearing caps and lower thrust washers in correct order.

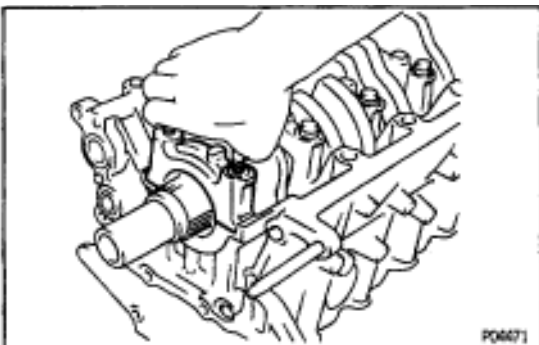

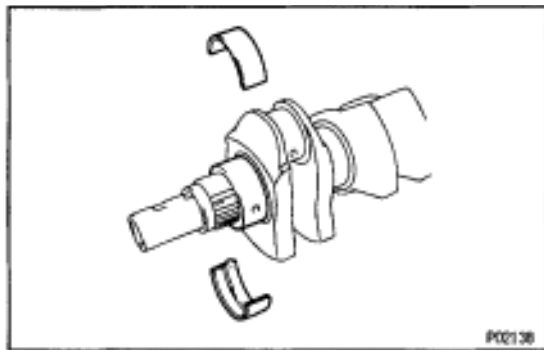

- (c) Lift out the crankshaft.
 HINT: Keep the upper bearing and upper thrust washers together with the cylinder block.
- (d) Clean each main journal and bearing.
- (e) Check each main journal and bearing for pitting and scratches.
 If the journal or bearing is damaged, replace the bearings. If necessary, grind or replace the crankshaft.

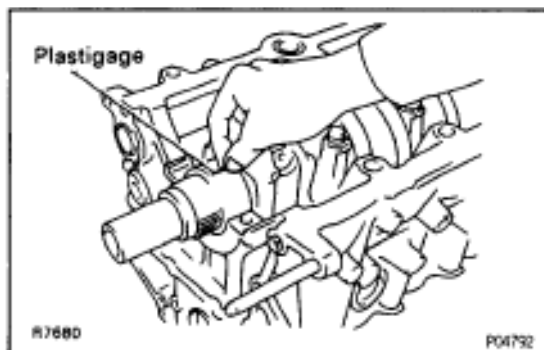

- (f) Place the crankshaft on the cylinder block.
- (g) Lay a strip of Plastigage across each journal.

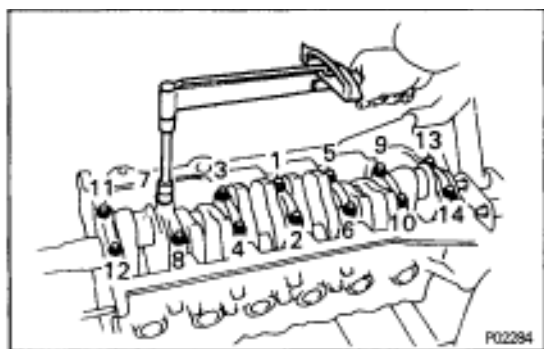

- (h) Install the main bearing caps.
 (See step 5 in cylinder block installation)
- Torque:**
- 1st
44 N·m (450 kgf·cm, 33 ft·lbf)
- 2nd
Turn 90°

NOTICE: Do not turn the crankshaft.

- (i) Remove the main bearing caps.
 (See procedures (a) and (b) above)
- (j) Measure the Plastigage at its widest point.

Standard clearance:

STD

.026–0.040 mm (0.0010–0.0016 in.)

U/S 0.25

.025–0.061 mm (0.0010–0.0024 in.)

Maximum clearance:

STD

.06 mm (0.0024 in.)

U/S 0.25

.08 mm (0.0031 in.)

If the oil clearance is greater than maximum, replace the bearings. If necessary, grind or replace the crankshaft.

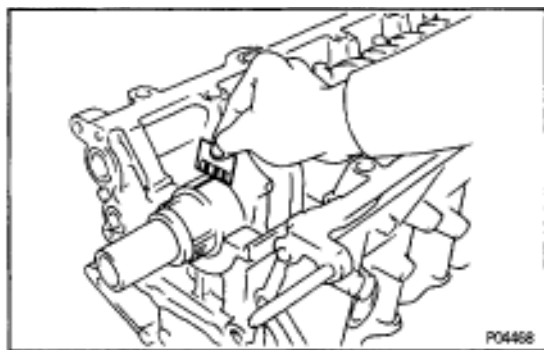

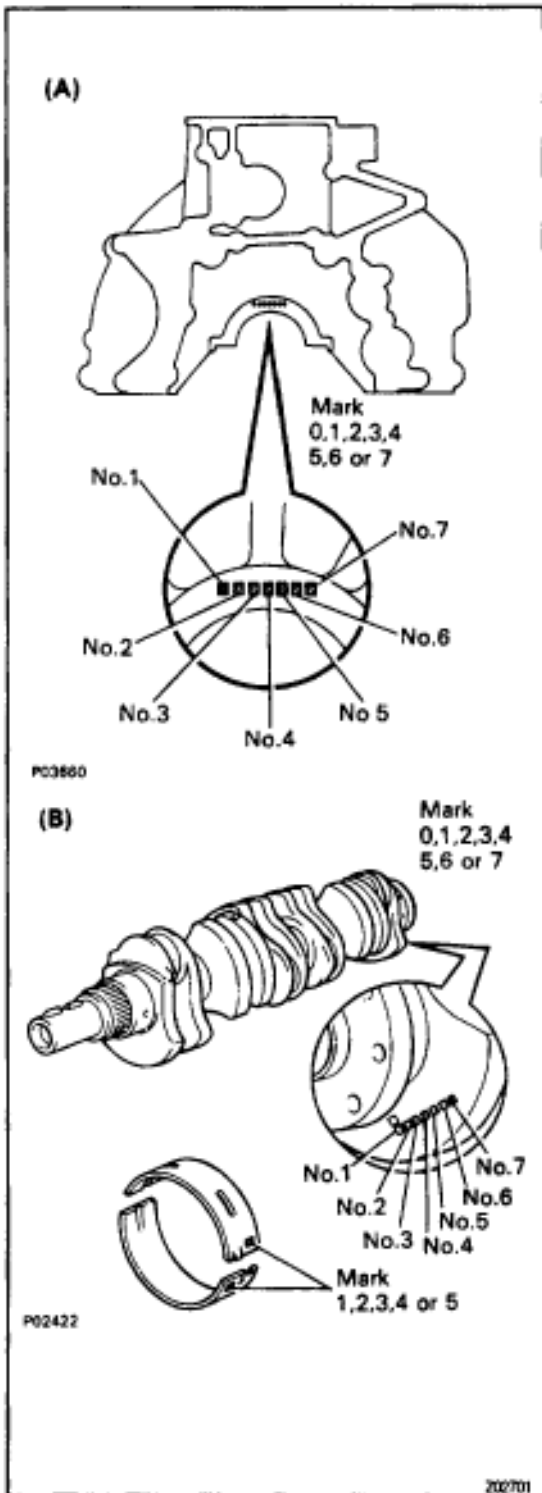

HINT: If using a standard bearing, replace with one having the same number. If the number of the bearing cannot be determined, select the correct bearing by adding together the numbers imprinted on the cylinder block and crankshaft, then refer to the table below for the appropriate bearing number. There are 5 sizes of standard bearings, marked "1", "2", "3", "4" and "5" accordingly.

	Total number " " :Number mark				
	0-2	3-5	6-8	9-11	12-14
Cylinder block (A) + Crankshaft (B) =					
Use bearing	"1"	"2"	"3"	"4"	"5"

EXAMPLE: Cylinder block "3" (A)
+ Crankshaft "4"(B)
= Total number 7 (Use bearing "3")

Reference:

Cylinder block main journal bore diameter (A):

- Mark "0"
66.020–66.022 mm (2.59922–2.59929 in.)
- Mark "1"
66.022–66.024 mm (2.59929–2.59936 in.)
- Mark "2"
66.024–66.026 mm (2.59936–2.59944 in.)
- Mark "3"
66.026–66.028 mm (2.59944–2.59952 in.)
- Mark "4"
66.028–66.030 mm (2.59952–2.59960 in.)
- Mark "5"
66.030–66.032 mm (2.59960–2.59968 in.)
- Mark "6"
66.032–66.034 mm (2.59968–2.59976 in.)
- Mark "7"
66.034–66.036 mm (2.59976–2.59984 in.)

Crankshaft main journal diameter (B):

- Mark "0"
61.998–62.000 mm (2.44086–2.44094 in.)
- Mark "1"
61.996–61.998 mm (2.44078–2.44086 in.)
- Mark "2"
61.994–61.996 mm (2.44070–2.44078 in.)
- Mark "3"
61.992–61.994 mm (2.44063–2.44070 in.)
- Mark "4"
61.990–61.992 mm (2.44055–2.44063 in.)
- Mark "5"
61.988–61.990 mm (2.44047–2.44055 in.)

Mark "6"

61.986–61.988 mm (2.44039–2.44047 in.)

Mark "7"

61.984–61.986 mm (2.44031–2.44039 in.)

Bearing center wall thickness:

Mark "1"

1.994–1.997 mm (0.0785–0.0786 in.)

Mark "2"

1.997–2.000 mm (0.0786–0.0787 in.)

Mark "3"

2.000–2.003 mm (0.0787–0.0789 in.)

Mark "4"

2.003–2.006 mm (0.0789–0.0790 in.)

Mark "5"

2.006–2.009 mm (0.0790–0.0791 in.)

Standard sized Bearing Selection chart

Crankshaft number mark	Cylinder block number mark							
	0	1	2	3	4	5	6	7
0	1	1	1	2	2	2	3	3
1	1	1	2	2	2	3	3	3
2	1	2	2	2	3	3	3	4
3	2	2	2	3	3	3	4	4
4	2	2	3	3	3	4	4	4
5	2	3	3	3	4	4	5	5
6	3	3	3	4	4	5	5	5
7	3	3	4	4	5	5	5	5

EXAMPLE: Cylinder block "3" Crankshaft "4"
= Use bearing "3"

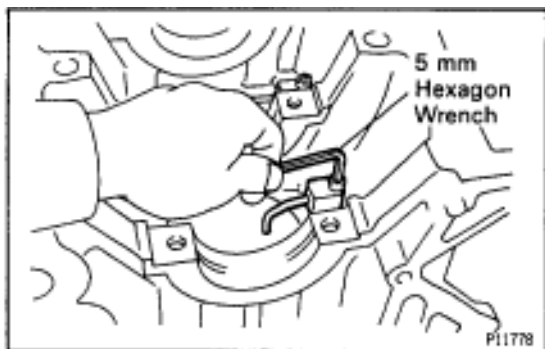
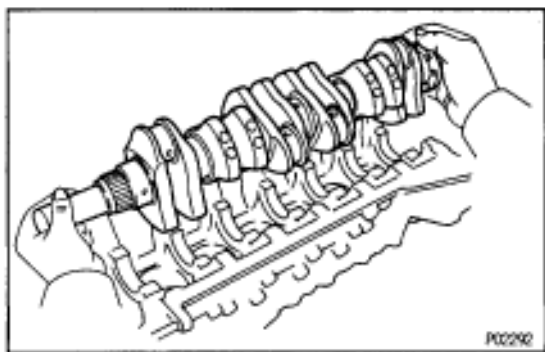

(k) Completely remove the Plastigage.

7. REMOVE CRANKSHAFT

(a) Lift out the crankshaft

(b) Remove the upper bearings and upper thrust washers from the cylinder block.

HINT: Arrange the main bearing caps, bearings and thrust washers in the correct order.

8. 2JZ-GTE:

REMOVE OIL NOZZLES (WITH RELIEF VALVES)

Using a 5 mm hexagon wrench, remove the bolt and oil nozzle. Remove the 6 oil nozzles.

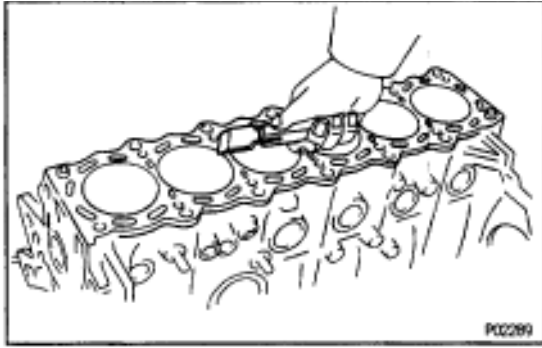

CYLINDER BLOCK INSPECTION

1. CLEAN CYLINDER BLOCK

A. Remove gasket material

Using a gasket scraper, remove all the gasket material from the cylinder block surface.

B. Clean cylinder block

Using a soft brush and solvent, thoroughly clean the cylinder block.

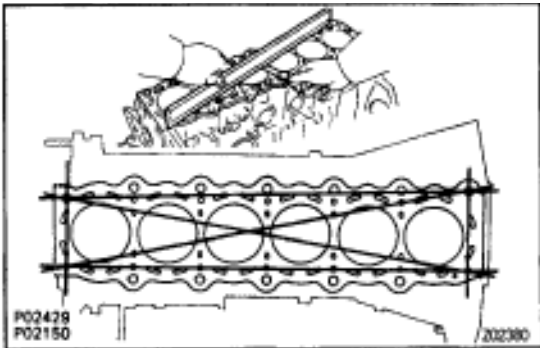

2. INSPECT CYLINDER BLOCK SURFACE FOR FLATNESS

Using precision straight edge and feeler gauge, measure the surfaces of the cylinder block for warpage.

Maximum warpage:

0.07 mm (0.0028 in.)

If warpage is greater than maximum, replace the cylinder block.

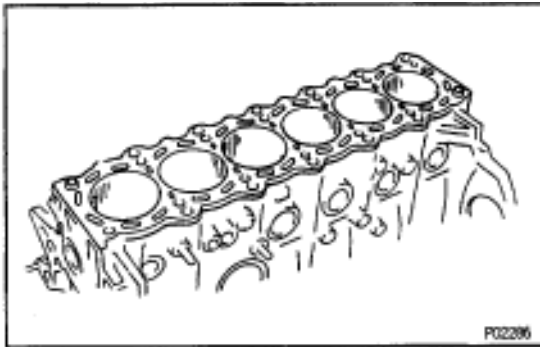

3. INSPECT CYLINDER FOR VERTICAL SCRATCHES

Visually check the cylinder for vertical scratches.

If deep scratches are present, replace the cylinder block.

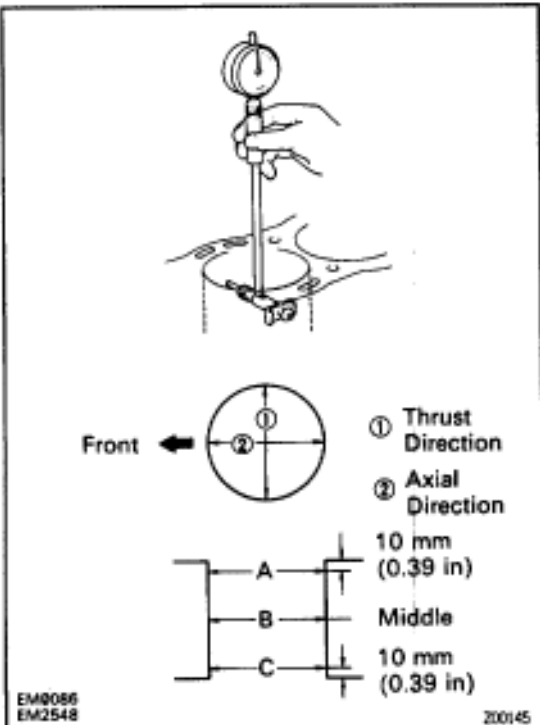

4. INSPECT CYLINDER BORE DIAMETER

Using a cylinder gauge, measure the cylinder bore diameter at positions A, B and C in the thrust and axial directions.

Standard diameter:

86.000–86.013 mm (3.3858–3.3863 in.)

Maximum diameter:

86.02 mm (3.3866 in.)

If the diameter is greater than maximum, replace the cylinder block.

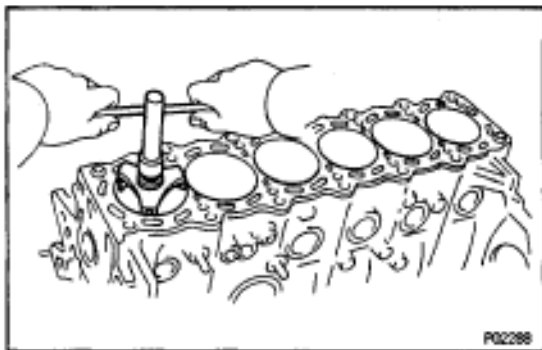

5. REMOVE CYLINDER RIDGE

If the wear is less than 0.2 mm (0.008 in.), using a ridge reamer, grind the top of the cylinder.

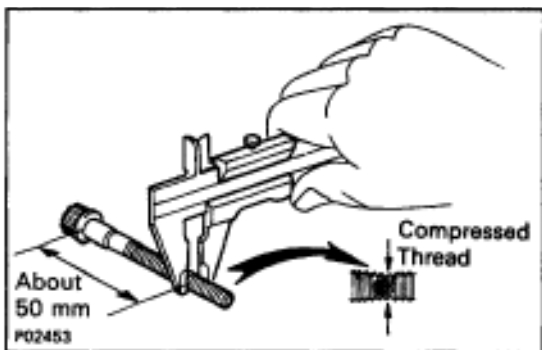

6. INSPECT MAIN BEARING CAP BOLTS

Using vernier calipers, measure the minimum diameter of the compressed thread at the measuring point.

Standard diameter:

9.96–9.97 mm (0.3921–0.3925 in.)

Minimum diameter:

9.7 mm (0.382 in.)

If the diameter is less than minimum, replace the bolt.

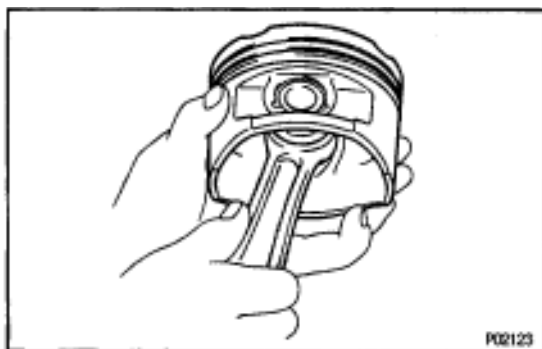

PISTON AND CONNECTING ROD DISASSEMBLY

1. CHECK FIT BETWEEN PISTON AND PISTON PIN

Try to move the piston back and forth on the piston pin.

If any movement is felt, replace the piston and pin as a set.

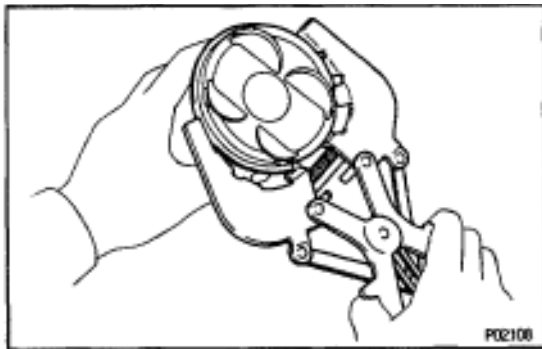

2. REMOVE PISTON RINGS

(a) Using a piston ring expander, remove the 2 compression rings.

(b) Remove the 2 side rails and oil ring expander by hand.
HINT: Arrange the piston rings in correct order only.

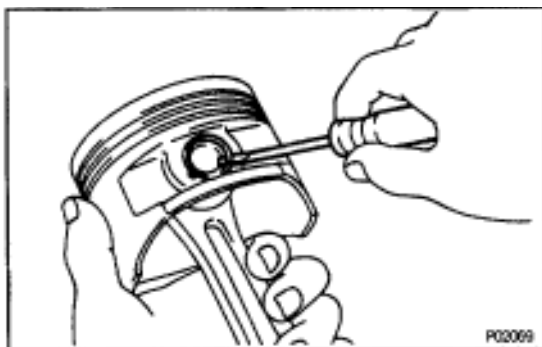

3. DISCONNECT CONNECTING ROD FROM PISTON

(a) Using a small screwdriver, remove the 2 snap rings.

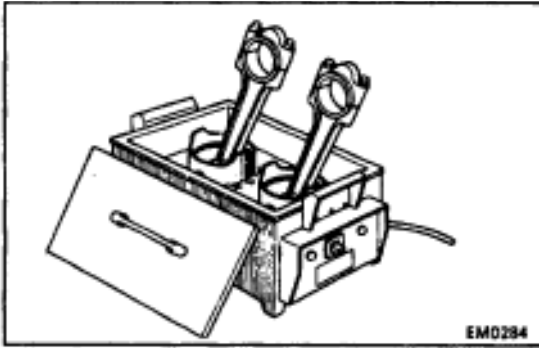

(b) Gradually heat the piston to about 80°C (176°F).

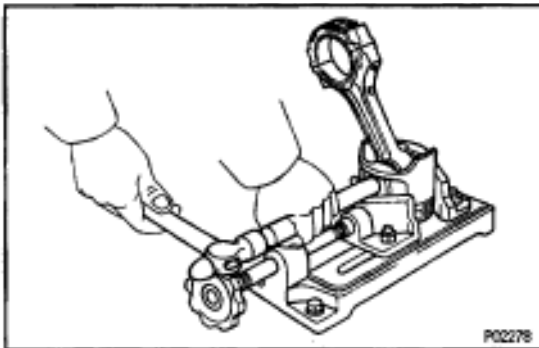

(c) Using a plastic-faced hammer and brass bar, lightly tap out the piston pin and remove the connecting rod.

HINT:

- The piston and pin are a matched set.
- Arrange the pistons, pins, rings, connecting rods and bearings in the correct order.

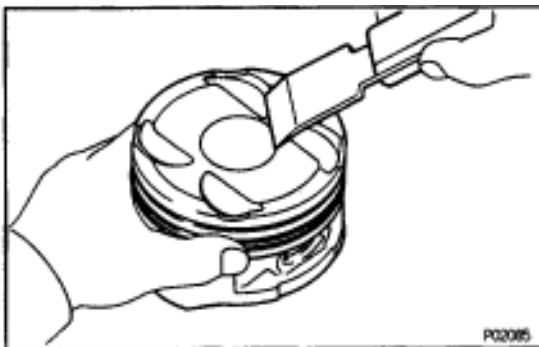

PISTON AND CONNECTING ROD INSPECTION

1. CLEAN PISTON

(a) Using a gasket scraper, remove the carbon from the piston top.

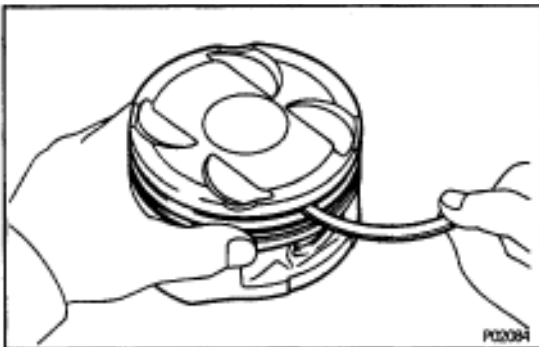

(b) Using a groove cleaning tool or broken ring, clean the piston ring grooves.

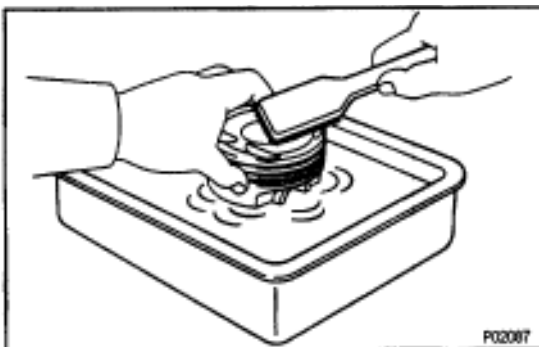

(c) Using solvent and a brush, thoroughly clean the piston.
NOTICE: Do not use a wire brush.

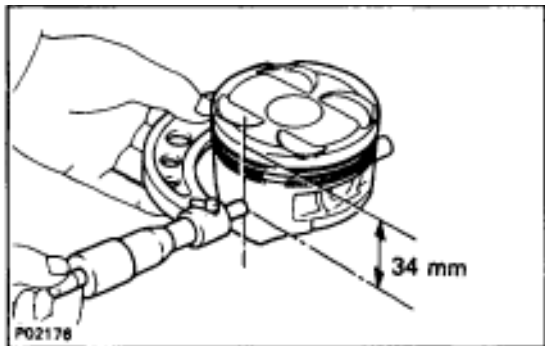

2. INSPECT PISTON

A. Inspect piston oil clearance

- (a) Using a micrometer, measure the piston diameter at right angles to the piston pin center line, 34 mm (1.34 in.) from the piston head.

Piston diameter:

2JZ-GE

85.935–85.945 mm (3.3833–3.3837 in.)

2JZ-GTE

85.917–85.927 mm (3.3826–3.3830 in.)

- (b) Measure the cylinder bore diameter in the thrust directions. (See step 4 in cylinder block inspection)
- (c) Subtract the piston diameter measurement from the cylinder bore diameter measurement.

Standard oil clearance:

2JZ-GE

.055–0.078 mm (0.0022–0.0031 in.)

2JZ-GTE

.073–0.096 mm (0.0029–0.0038 in.)

Maximum oil clearance:

2JZ-GE

.10 mm (0.0039 in.)

2JZ-GTE

.12 mm (0.0047 in.)

If the oil clearance is greater than maximum, replace all the 6 pistons. If necessary, replace the cylinder block.

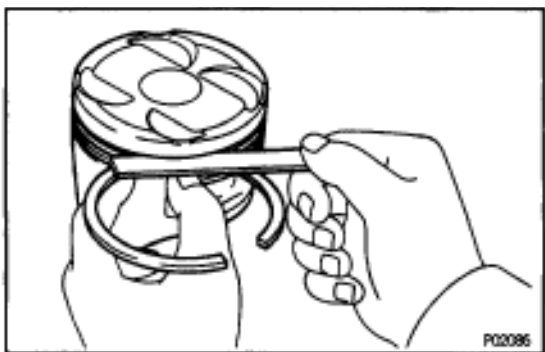

B. Inspect piston ring groove clearance

Using a feeler gauge, measure the clearance between new piston ring and the wall of the piston ring groove.

Ring groove clearance:

No.1

2JZ-GE

0.011–0.070 mm (0.0004–0.0028 in.)

2JZ-GTE

0.040–0.080 mm (0.0016–0.0031 in.)

No.2

.030–0.070 mm (0.0012–0.0028 in.)

If the clearance is not as specified, replace the piston.

C. Inspect piston ring end gap

- (a) Insert the piston ring into the cylinder bore.
- (b) Using a piston, push the piston ring a little beyond the bottom of the ring travel, 105 mm (4.13 in.) from the top of the cylinder block.

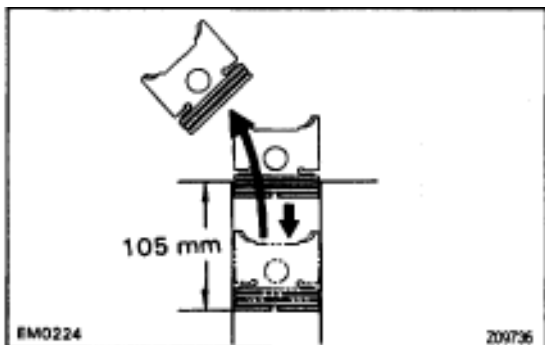

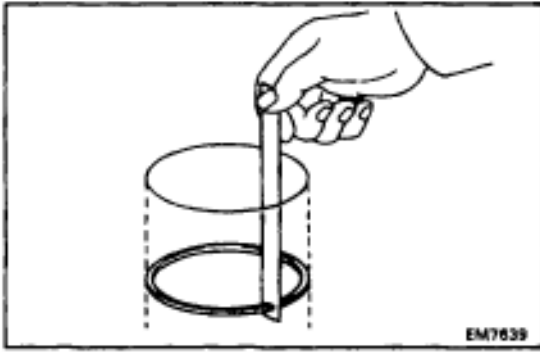

(c) Using a feeler gauge, measure the ring end gap.

Standard ring end gap:

No.1

2JZ-GE

0.300–0.470 mm (0.0118–0.0185 in.)

2JZ-GTE

0.300–0.400 mm (0.0118–0.0157 in.)

No.2

2JZ-GE

0.350–0.520 mm (0.0138–0.0205 in.)

2JZ-GTE

0.350–0.450 mm (0.0138–0.0178 in.)

Oil (Side rail)

2JZ-GE

0.130–0.450 mm (0.0051–0.0177 in.)

2JZ-GTE

0.130–0.380 mm (0.0051–0.0150 in.)

Maximum ring end gap:

No.1

2JZ-GE

1.07 mm (0.0421 in.)

2JZ-GTE

1.00 mm (0.0394 in.)

No.2

2JZ-GE

1.12 mm (0.0441 in.)

2JZ-GTE

1.05 mm (0.0413 in.)

Oil (Side rail)

2JZ-GE

1.05 mm (0.0413 in.)

2JZ-GTE

0.98 mm (0.0386 in.)

If the end gap is greater than maximum, replace the piston ring. If the end gap is greater than maximum, even with a new piston ring, replace the cylinder block.

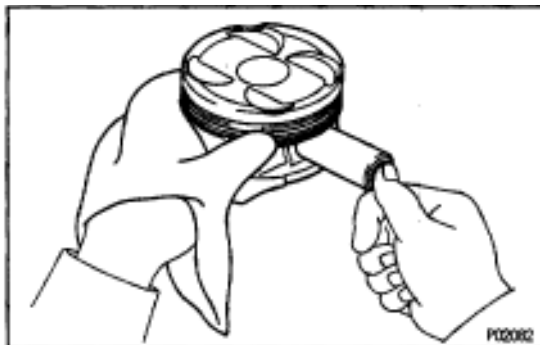

D. Inspect piston pin fit

At 80°C (176°F), you should be able to push the piston pin into the piston pin hole with your thumb.

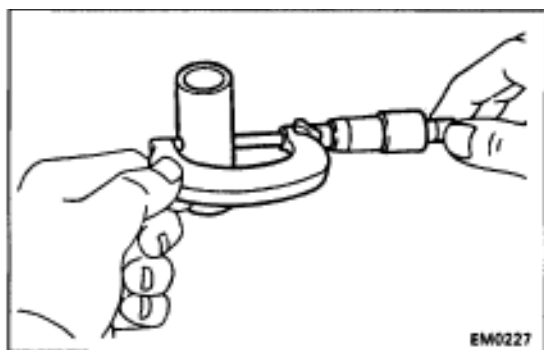
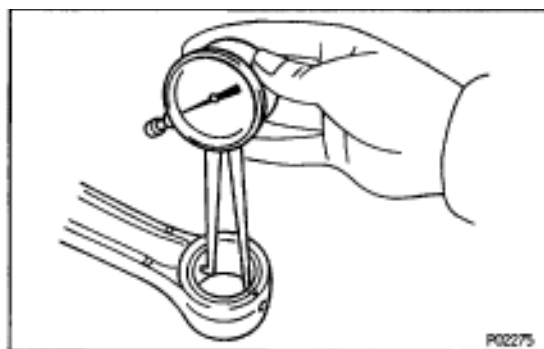
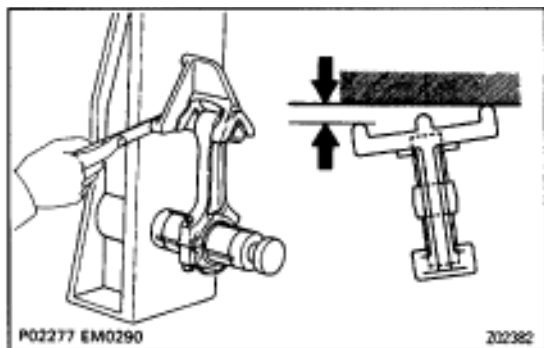
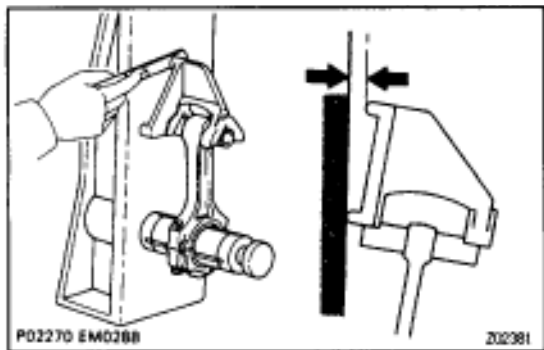

3. INSPECT CONNECTING ROD

A. Inspect connecting rod alignment

Using a feeler gauge and rod aligner, check the connecting rod alignment.

- Check for out-of-alignment

Maximum out-of-alignment:

0.05 mm (0.0020 in.) per 100 mm (3.94 in.)

If out-of-alignment is greater than maximum, replace the connecting rod assembly.

- Check for twist

Maximum twist:

0.15 mm (0.0059 in.) per 100 mm (3.94 in.)

If twist is greater than maximum, replace the connecting rod assembly.

B. Inspect piston pin oil clearance

- (a) Using a caliper gauge, measure the inside diameter of the connecting rod bushing.

Bushing inside diameter:

22.005–22.014 mm (0.8663–0.8667 in.)

- (b) Using a micrometer, measure the piston pin diameter.

Piston pin diameter:

21.997–22.006 mm (0.8660–0.8664 in.)

- (c) Subtract the piston pin diameter measurement from the bushing inside diameter measurement.

Standard oil clearance:

0.005–0.011 mm (0.0002–0.0004 in.)

Maximum oil clearance:

0.05 mm (0.0020 in.)

If the oil clearance is greater than maximum, replace the bushing. If necessary, replace the piston and piston pin as a set.

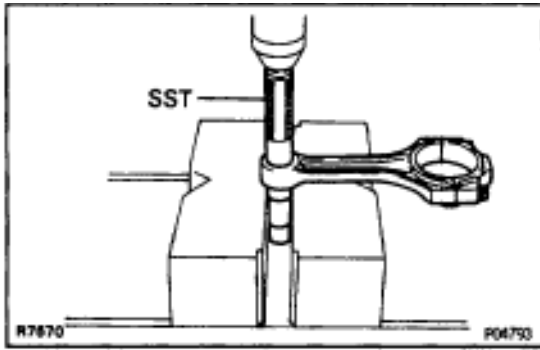

C. If necessary, replace connecting rod bushing

- (a) Using SST and a press, press out the bushing.
SST 09222-30010

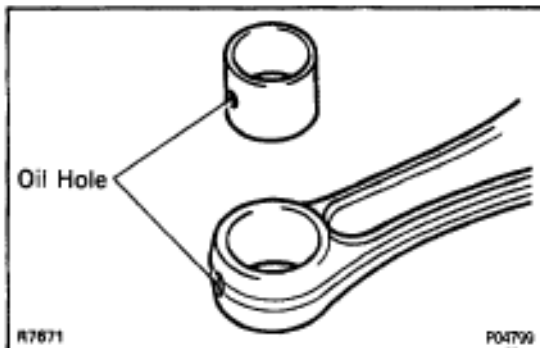

- (b) Align the oil holes of a new bushing and the connecting rod.
(c) Using SST and a press, press in the bushing.
SST 09222-30010

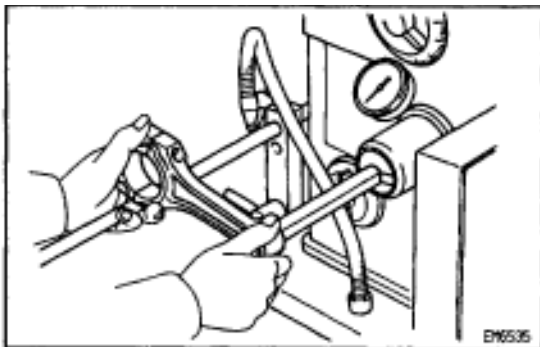

- (d) Using a pin hole grinder, bore the bushing to obtain the standard specified clearance (see step B) between the bushing and piston pin.

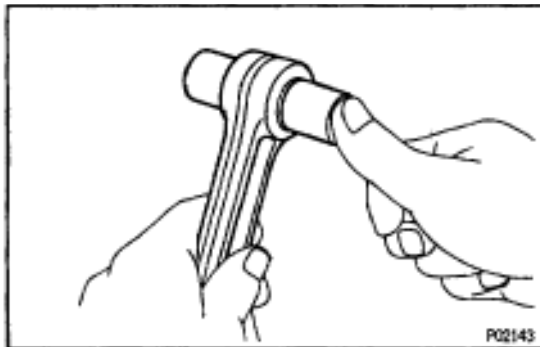

- (e) Check the piston pin fit at room temperature.
Coat the piston pin with engine oil and push it into the connecting rod with your thumb.

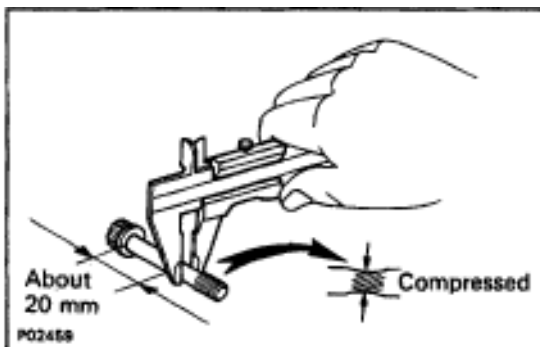

D. Inspect connecting rod bolts

Using vernier calipers, measure the minimum diameter of the compressed bolt at the measuring point.

Standard diameter:

8.1–8.3 mm (0.319–0.327 in.)

Minimum diameter:

8.0 mm (0.315 in.)

If the diameter is less than minimum, replace the connecting rod bolt.

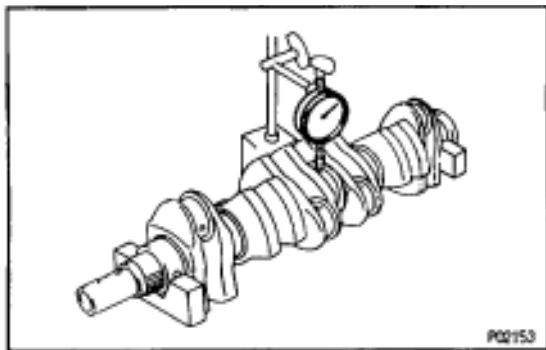

CRANKSHAFT INSPECTION

1. INSPECT CRANKSHAFT FOR RUNOUT

- (a) Place the crankshaft on V-blocks.
- (b) Using a dial indicator, measure the circle runout at the center journal.

Maximum circle runout:

0.06 mm (0.0024 in.)

If the circle runout is greater than maximum, replace the crankshaft.

2. INSPECT MAIN JOURNALS AND CRANK PINS

- (a) Using a micrometer, measure the diameter of each main journal and crank pin.

Main journal diameter:

STD

61.984–62.000 mm (2.4403–2.4409 in.)

U/S 0.25

61.745–61.755 mm (2.4309–2.4313 in.)

Crank pin diameter:

STD

51.982–52.000 mm (2.0465–2.0472 in.)

U/S 0.25

51.745–51.755 mm (2.0372–2.0376 in.)

If the diameter is not as specified, check the oil clearance. (See steps 3 and 6 in cylinder block disassembly)

- (b) Check each main journal and crank pin for taper and out-of-round as shown.

Maximum taper and out-of-round:

0.02 mm (0.0008 in.)

If the taper or out-of-round is greater than maximum, grind or replace the crankshaft.

3. IF NECESSARY, GRIND AND HONE MAIN JOURNALS AND/OR CRANK PINS

Grind and hone the main journals and/or crank pins to the finished undersized diameter (See procedure step 2).

Install new main journal and/or crank pin undersized bearings.

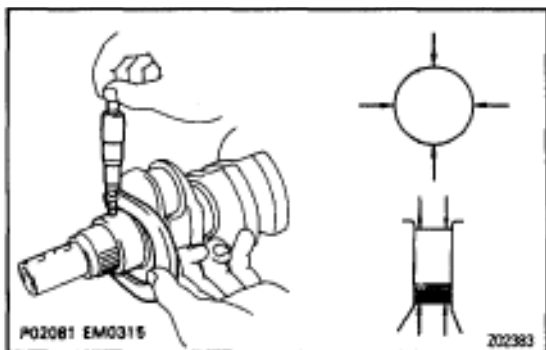

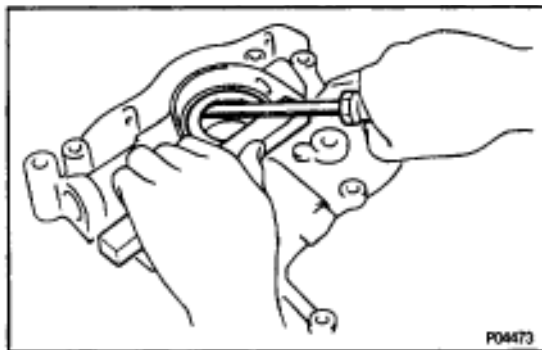

CRANKSHAFT OIL SEALS REPLACEMENT

HINT: There are 2 methods A and B to replace the oil seal as follows:

1. REPLACE CRANKSHAFT FRONT OIL SEAL

A. If oil pump is removed from cylinder block:

- (a) Using a screwdriver, pry out the oil seal.
- (b) Using SST and a hammer, tap in a new oil seal until its surface is flush with the oil pump body edge.
SST 09316-60010 (09316-00010)
- (c) Apply MP grease to the oil seal lip.

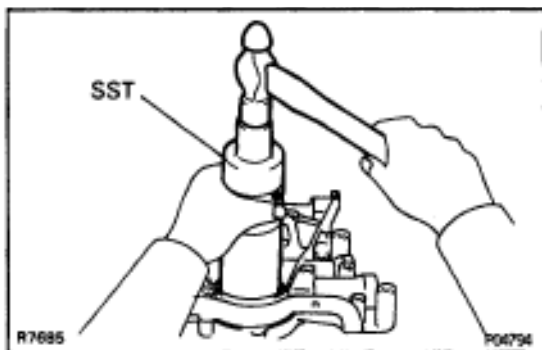

B. If oil pump is installed on cylinder block:

- (a) Using a knife, cut off the oil seal lip.
- (b) Using a screwdriver, pry out the oil seal.
NOTICE: Be careful not to damage the crankshaft. Tape the screwdriver tip.

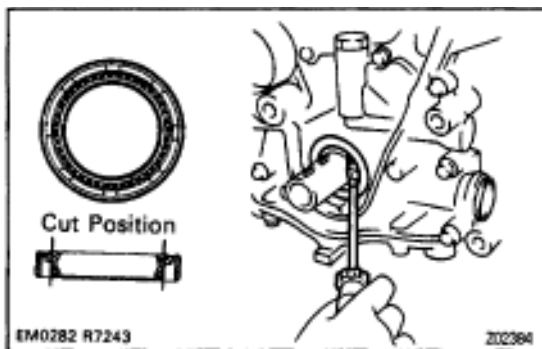

- (c) Apply MP grease to a new oil seal lip.
- (d) Using SST and a hammer, tap in the oil seal until its surface is flush with the oil pump body edge.
SST 09316-60010 (09316-00010)

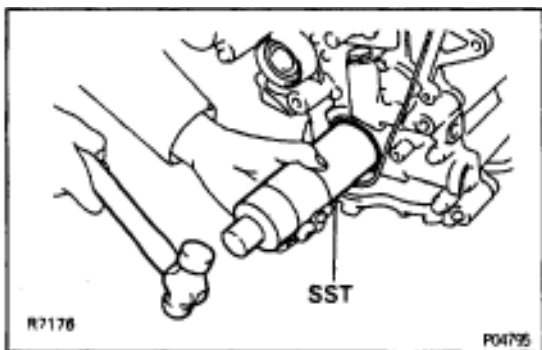

2. REPLACE CRANKSHAFT REAR OIL SEAL

A. If rear oil seal retainer is removed from cylinder block:

- (a) Using a screwdriver and hammer, tap out the oil seal.

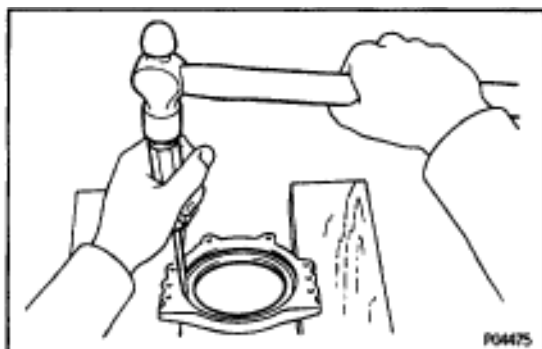

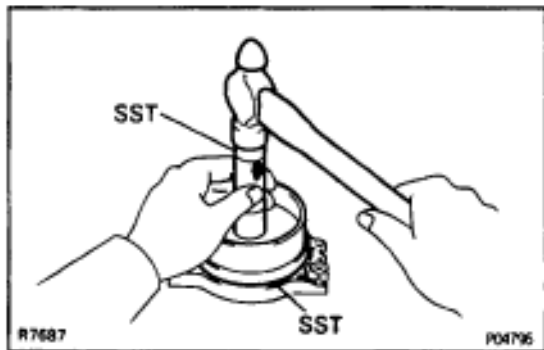

- (b) Using SST and a hammer, tap in a new oil seal until its surface is flush with the rear oil seal retainer edge.
SST 09223-15030, 09608-30022 (09608-05010)
- (c) Apply MP grease to the oil seal lip.

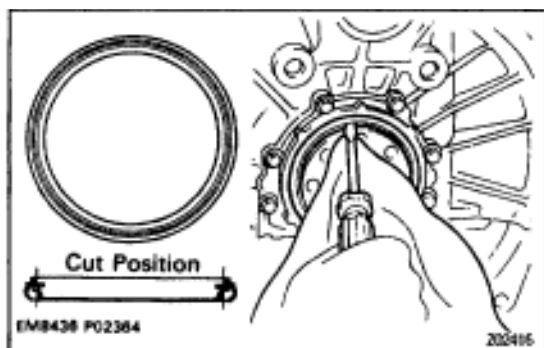

- B. If rear oil seal retainer is installed on cylinder block:**
- (a) Using a knife, cut off the oil seal lip.
 - (b) Using a screwdriver, pry out the oil seal.
NOTICE: Be careful not to damage the crankshaft. Tape the screwdriver tip.

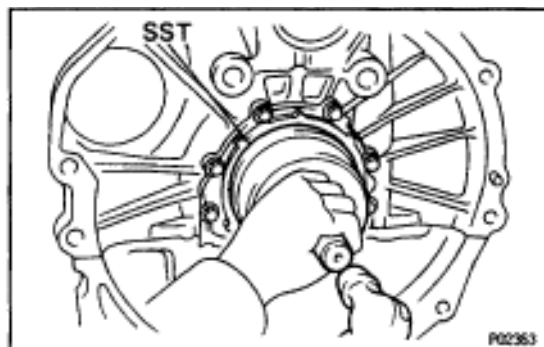

- (c) Apply MP grease to a new oil seal lip.
- (d) Using SST and a hammer, tap in the oil seal until its surface is flush with the rear oil seal retainer edge.
SST 09223-15030, 09608-30022 (09608-05010)



PISTON AND CONNECTING ROD ASSEMBLY

1. ASSEMBLE PISTON AND CONNECTING ROD

- (a) Install a new snap ring at one end of the piston pin hole.
HINT: Be sure that end gap of the snap ring is not aligned with the pin hole cutout portion of the piston.

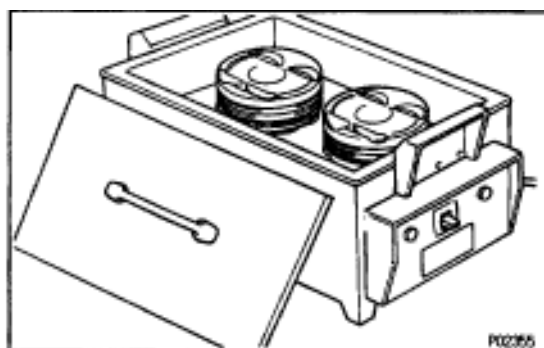

- (b) Gradually heat the piston to about 80°C (176°F).

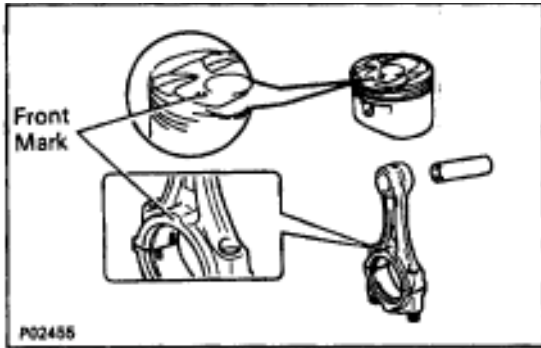

- (c) Coat the piston pin with engine oil.
- (d) Align the front marks of the piston and connecting rod, and push in the piston pin with your thumb.



- (e) Install a new snap ring at the other end of the piston pin hole.
HINT: Be sure that end gap of the snap ring is not aligned with the pin hole cutout portion of the piston.

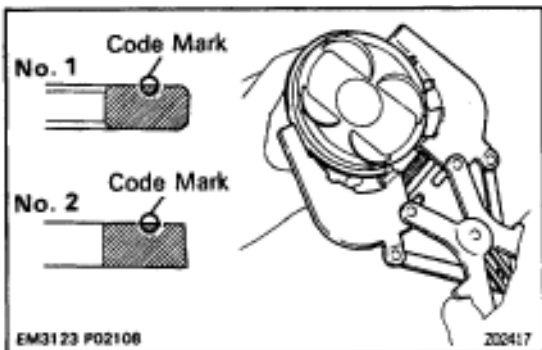

2. INSTALL PISTON RINGS

- (a) Install the oil ring expander and 2 side rails by hand.
- (b) Using a piston ring expander, install the 2 compression rings with the code mark facing up.

Code mark:

2JZ-GE

No.1 1T

No.2 2T

2JZ-GTE

No.1 1N

No.2 2N

- (c) Position the piston rings so that the ring ends are as shown.
NOTICE: Do not align the piston ring ends.

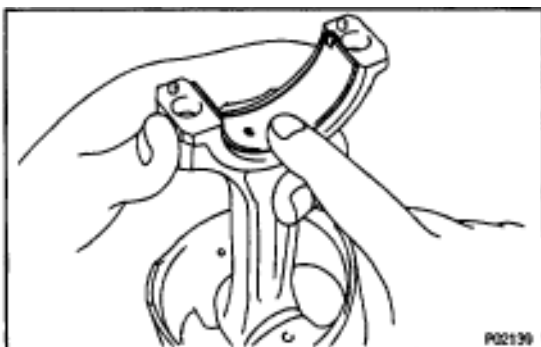
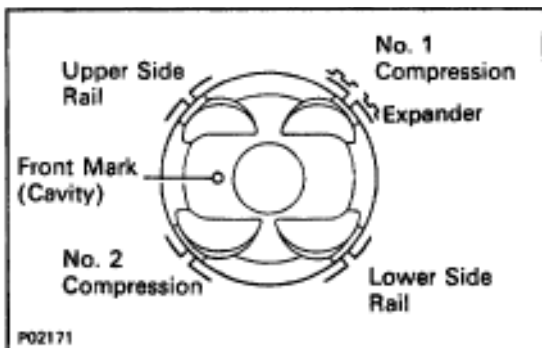

3. INSTALL BEARINGS

- (a) Align the bearing claw with the groove of the connecting rod and connecting cap.
- (b) Install the bearings in the connecting rod and connecting rod cap.

CYLINDER BLOCK ASSEMBLY

HINT:

- Thoroughly clean all parts to be assembled.
- Before installing the parts, apply new engine oil to all sliding and rotating surfaces.
- Replace all gaskets, O-rings and oil seals with new parts.

NOTICE: Apply a generous amount of oil on the sliding surface of the bearing, and not on the back of it or on the surface to which it is installed.

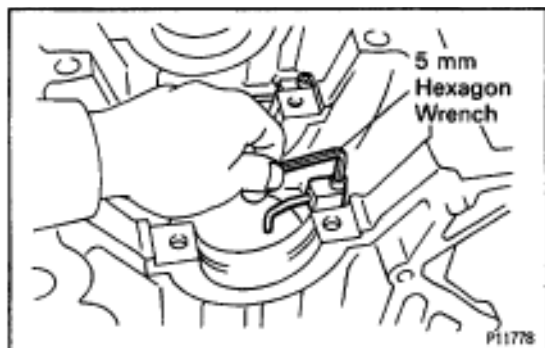

1. 2JZ-GTE:

INSTALL OIL NOZZLES (WITH RELIEF VALVES)

Using a 5 mm hexagon wrench, install the oil nozzle with the bolt. Install the 6 oil nozzles.

Torque: 8.8 N·m (90 kgf·cm, 78 in·lbf)

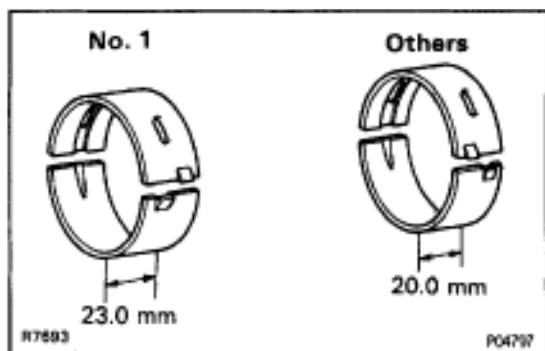

2. INSTALL MAIN BEARINGS

HINT:

- Main bearings come in widths of 20.0 mm (0.787 in.) and 23.0 mm (0.906 in.). Install the 23.0 mm bearings in the No.1 cylinder block journal position with the main bearing cap. Install the 20.0 mm bearings in the other positions.
- Upper bearings have an oil groove and oil holes; lower bearings do not.

- (a) Align the bearing claw with the claw groove of the main bearing cap or cylinder block.

NOTICE: Install the bearing with the oil hole in the cylinder block.

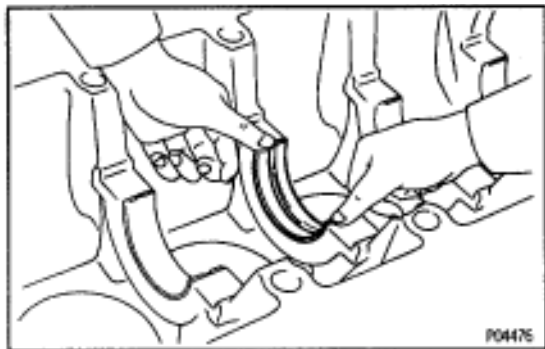

- (b) Install the bearings in the cylinder block and main bearing caps.

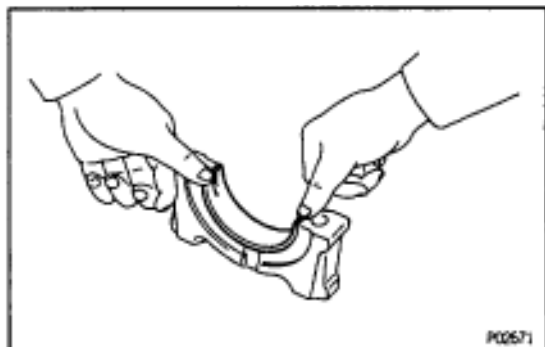

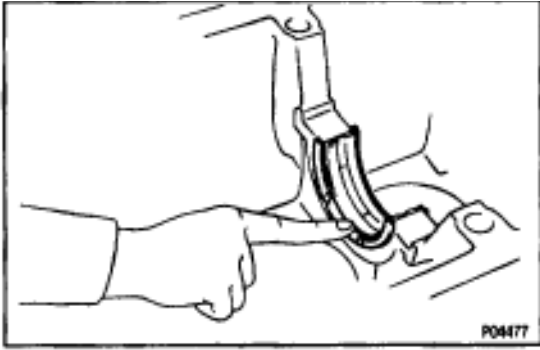

3. INSTALL UPPER THRUST WASHERS

Install the 2 thrust washers under the No.4 main journal position of the cylinder block with the oil grooves facing outward.

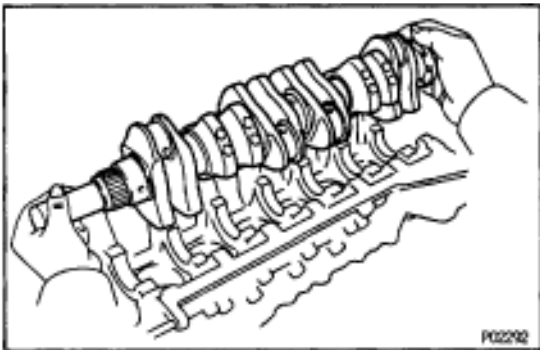

4. PLACE CRANKSHAFT ON CYLINDER BLOCK

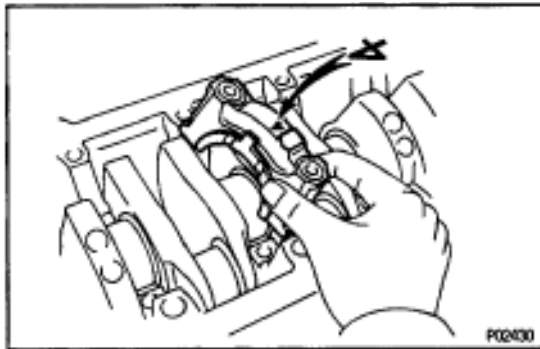

5. INSTALL MAIN BEARING CAP AND LOWER THRUST WASHERS

A. Place main bearing cap and lower thrust washers on cylinder block

(a) Install the lower thrust washers on the No.4 main bearing with the grooves facing outward.

(b) Install the main bearing caps in numerical order with the arrows facing forward.

B. Install main bearing cap bolts

HINT:

- The main bearing cap bolts are tightened in 2 progressive steps (steps (b) and (d)).
- If any of the main bearing bolts break or deform, replace them.

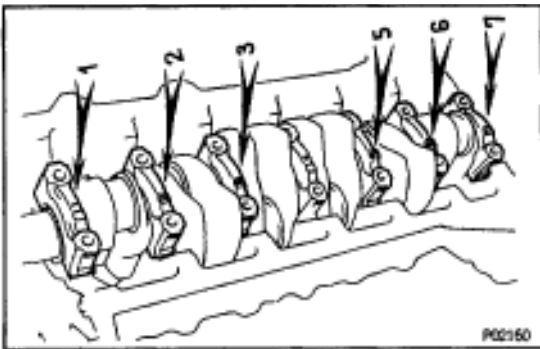

(a) Apply a light coat of engine oil on the threads and under the heads of the main bearing cap bolts.

(b) Install and uniformly tighten the 14 main bearing cap bolts, in several passes, in the sequence shown.

Torque: 44 N·m (450 kgf·cm, 33 ft·lbf)

If any one of the main bearing cap bolts does not meet the torque specification, replace the main bearing cap bolt.

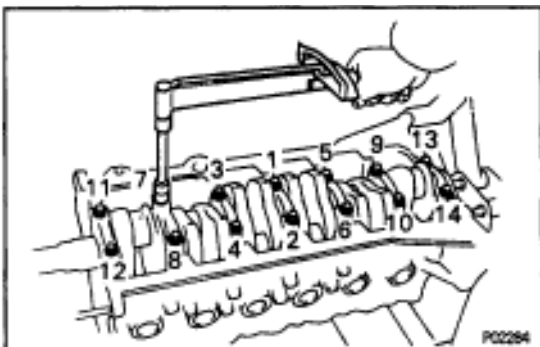

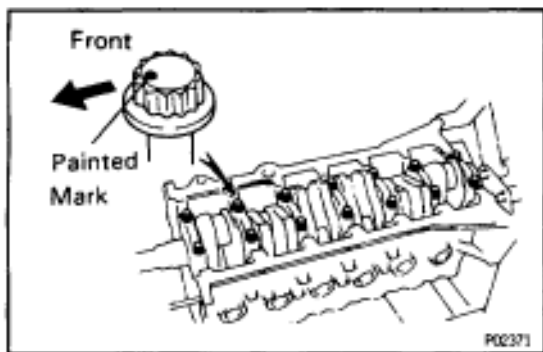

(c) Mark the front of the main bearing cap bolt head with paint.

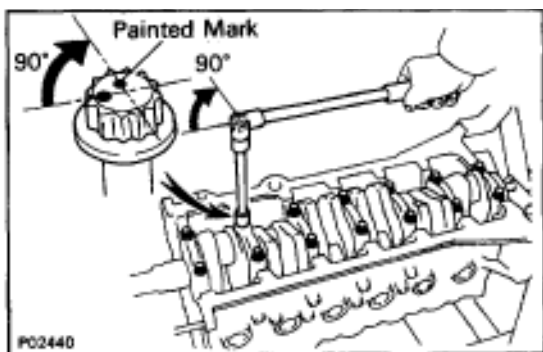

(d) Retighten the main bearing cap bolts 90° in the numerical order shown above.

(e) Check that the painted mark is now at a 90° angle to the front.

(f) Check that the crankshaft turns smoothly.

6. CHECK CRANKSHAFT THRUST CLEARANCE
(See step 5 in cylinder block disassembly)

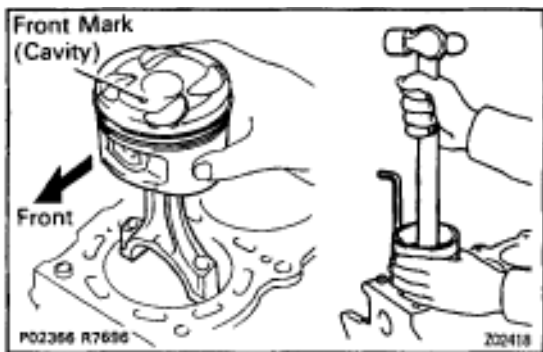

7. INSTALL PISTON AND CONNECTING ROD ASSEMBLIES

Using a piston ring compressor, push the correctly numbered piston and connecting rod assemblies into each cylinder with the front mark of the piston facing forward.

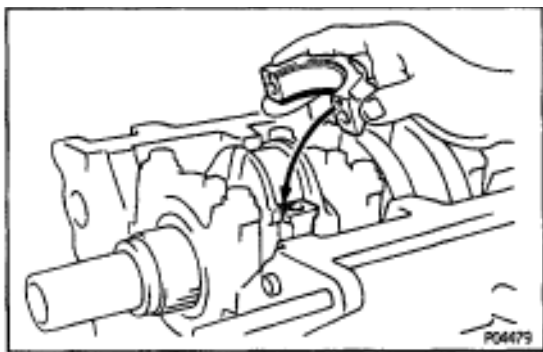

8. INSTALL CONNECTING ROD CAPS

A. Place connecting rod cap on connecting rod

(a) Match the numbered connecting rod cap with the connecting rod.

(b) Install the connecting rod cap with by aligning the dowel pin to the corresponding hole.

B. Install connecting rod cap bolts

HINT:

- The connecting rod cap bolts are tightened in 2 progressive steps (steps (b) and (d)).
- If any of the connecting rod bolts break or deform, replace them.

(a) Apply a light coat of engine oil on the threads and under the heads of the connecting rod cap bolts.

(b) At first, install and alternately tighten the bolts of the connecting rod cap in several passes.

Torque: 29 N·m (300 kgf·cm, 22 ft·lbf)

If any one of the connecting rod cap bolts does not meet the torque specification, replace the cap bolt.

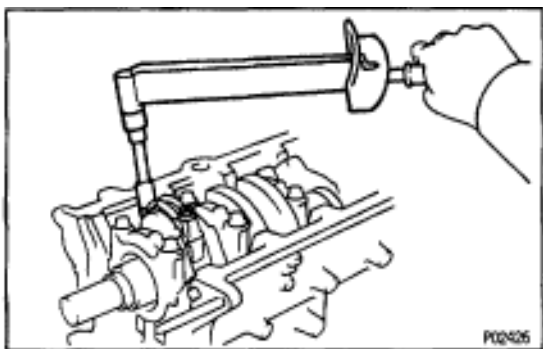

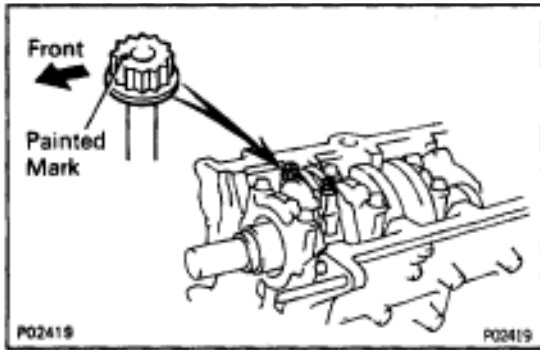

(c) Mark the front of the connecting rod cap bolt with paint.

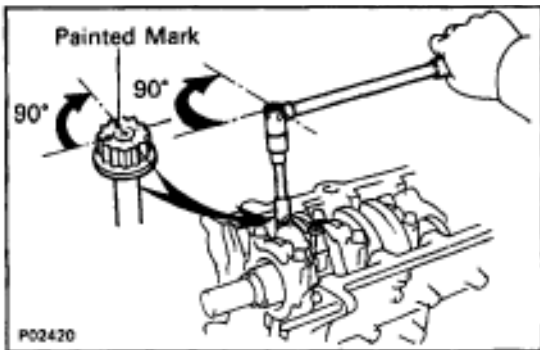

(d) Retighten the connecting rod cap bolts 90° in the numerical order shown.

(e) Check that the painted mark is now at a 90° angle to the front.

(f) Check that the crankshaft turns smoothly.

9. CHECK CONNECTING ROD THRUST CLEARANCE (See step 2 in cylinder block disassembly)

10. INSTALL REAR OIL SEAL RETAINER

(a) Remove any old packing (FIPG) material and be careful not to drop any oil on the contact surfaces of the retainer and cylinder block.

- Using a razor blade and gasket scraper, remove all the old packing (FIPG) material from the gasket surfaces and sealing groove.
- Thoroughly clean all components to remove all debris.
- Using a non-residue solvent, clean both sealing surfaces.

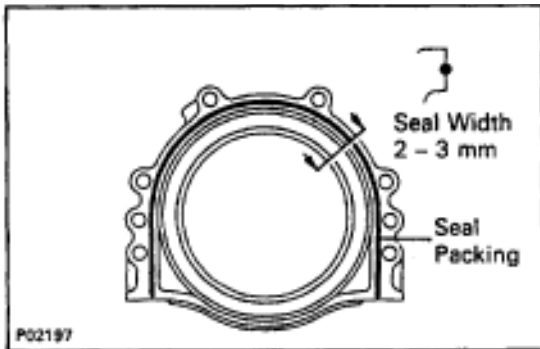

(b) Apply seal packing to the retainer as shown in the illustration.
Seal packing:

Part No. 08826-00080 or equivalent

- Install a nozzle that has been cut to a 2–3 mm (0.08–0.12 in.) opening.
- Parts must be assembled within 3 minutes of application. Otherwise the material must be removed and reapplied.
- Immediately remove nozzle from the tube and reinstall cap.

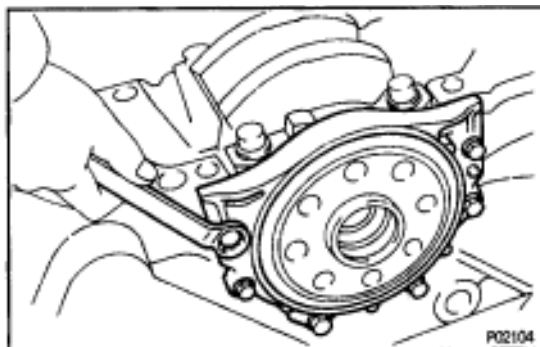

(c) Install the retainer with the 6 bolts.

Torque: 5.9 N·m (60 kgf·cm, 52 in.·lbf)

AFTER ASSEMBLY

1. **INSTALL OIL PUMP**
(See oil pump installation in Lubrication System)
2. **INSTALL WATER PUMP**
(See water pump installation in Cooling System)
3. **2JZ-GTE:**
INSTALL CRANKSHAFT POSITION SENSOR
Torque: 8.8 N·m (90 kgf·cm, 78 in·lbf)
4. **INSTALL RH ENGINE MOUNTING BRACKET AND INSULATOR ASSEMBLY**
HINT: The RH mounting bracket is marked "A ← EX".
Torque: 58 N·m (590 kgf·cm, 43 ft·lbf)
5. **INSTALL ENGINE COOLANT DRAIN PLUG**
Torque: 29 N·m (300 kgf·cm, 22 ft·lbf)

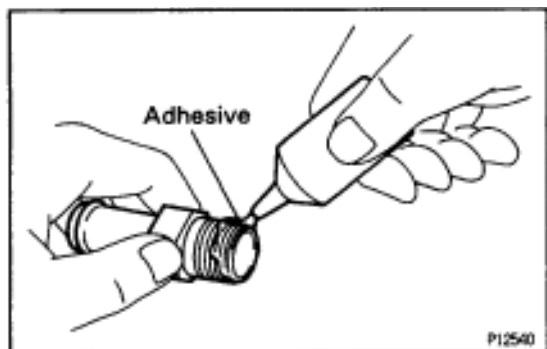

6. **2JZ-GTE:**
INSTALL UNION FOR OIL COOLER HOSE
 - (a) Apply adhesive to 2 or 3 threads of the union.
Adhesive:
Part No. 08833-00070, THREE BOND 1324, or equivalent
 - (b) Install the union.
Torque: 39 N·m (400 kgf·cm, 29 ft·lbf)

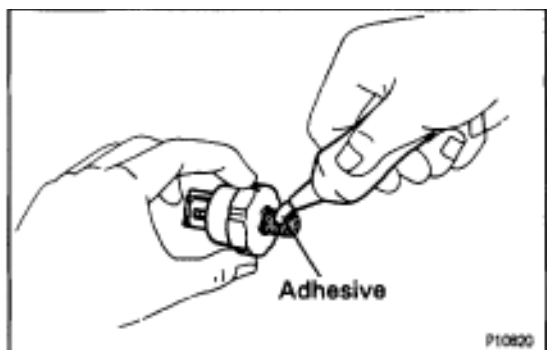

7. **INSTALL KNOCK SENSORS AND OIL PRESSURE SWITCH**
 - (a) Apply adhesive to 2 or 3 threads of the oil pressure switch.
Adhesive:
Part No. 08833-00080, THREE BOND 1344, LOCTITE 242 or equivalent

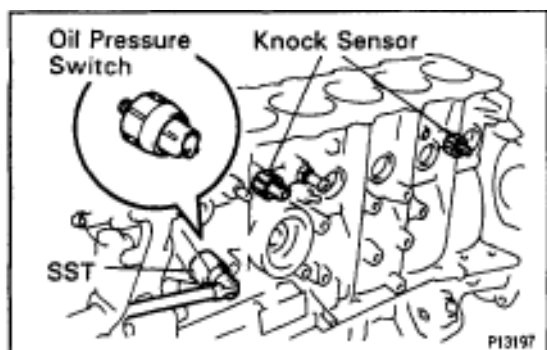

- (b) Using SST, install the 2 knock sensors and oil pressure switch.
SST 09816-30010
Torque:
Knock sensor
44 N·m (450 kgf·cm, 33 ft·lbf)
Oil pressure switch
14 N·m (150 kgf·cm, 11 ft·lbf)

8. **INSTALL FUEL PIPE SUPPORT**
Torque: 14 N·m (145 kgf·cm, 10 ft·lbf)
9. **INSTALL LH ENGINE MOUNTING BRACKET AND INSULATOR ASSEMBLY**
HINT: LH mounting bracket is marked "A ← IN".
Torque: 58 N·m (590 kgf·cm, 43 ft·lbf)
10. **INSTALL OIL FILTER BRACKET**
 - (a) Check and clean the oil filter bracket installation.
 - (b) Place a new O-ring in position on the oil filter bracket.
 - (c) Apply clean engine oil to the O-ring.
 - (d) Install a new gasket to the union bolt.
 - (e) Install the oil filter bracket with the union bolt.
Torque: 88 N·m (900 kgf·cm, 65 ft·lbf)
11. **INSTALL NO.2 WATER BYPASS PIPE**
 - (a) Install a new gasket to the water pump.
 - (b) 2JZ-GE:
Install the water bypass pipe with the bolt and 2 nuts.
Torque: 21 N·m (210 kgf·cm, 15 ft·lbf)
 - (c) 2JZ-GTE:
Install the water bypass pipe with the 2 bolts and 2 nuts.
Torque: 21 N·m (210 kgf·cm, 15 ft·lbf)
12. **2JZ-GTE:**
INSTALL OIL COOLER
(See oil cooler installation in Lubrication System)
13. **INSTALL OIL FILTER**
(See oil and filter replacement in Lubrication System)
14. **INSTALL CYLINDER HEAD**
(See cylinder head installation)
15. **INSTALL TIMING PULLEYS AND BELT**
(See timing belt installation)
16. **INSTALL GENERATOR**
(See generator installation in Charging System)
17. **REMOVE ENGINE STAND FROM ENGINE**

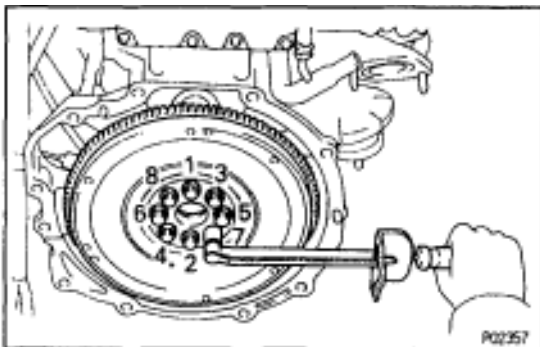

18. **M/T:**
INSTALL FLYWHEEL
HINT: The flywheel bolts are tightened in 2 progressive step, (b) and (d).
 - (a) Install the flywheel on the crankshaft.
 - (b) Install and uniformly tighten the 8 bolts, in several passes, in the sequence shown.
Torque: 49 N·m (500 kgf·cm, 36 ft·lbf)

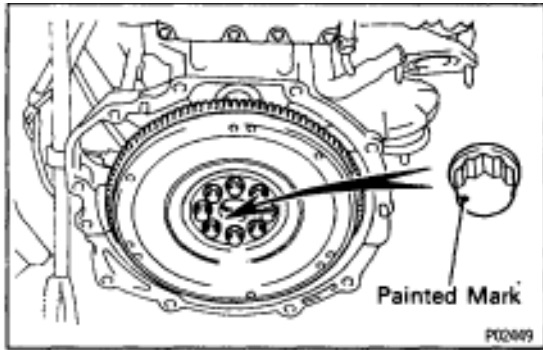

- (c) Mark the flywheel bolt with paint.

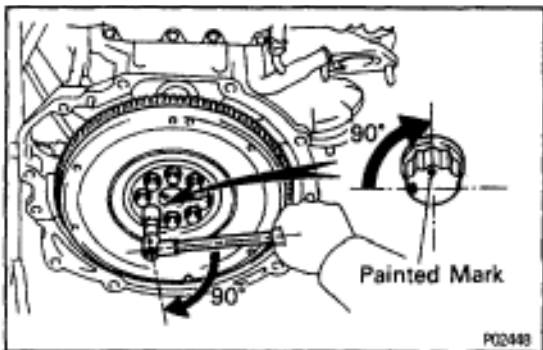

- (d) Retighten the flywheel bolts by an additional 90°.
 (e) Check that the painted mark is now at a 90° angle to (d).

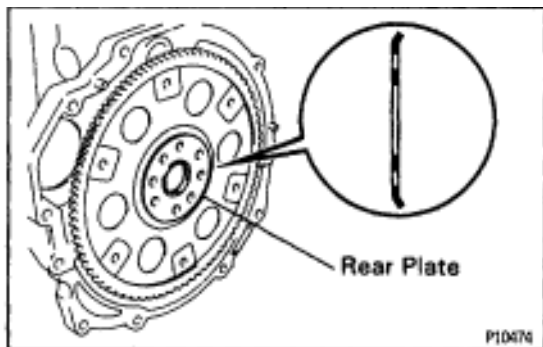

19. **A/T:**
INSTALL DRIVE PLATE

- (a) Install the front spacer, drive plate and rear plate on the crankshaft.

Adhesive:

Part No. 08833-00070, THREE BOND 1324 or equivalent

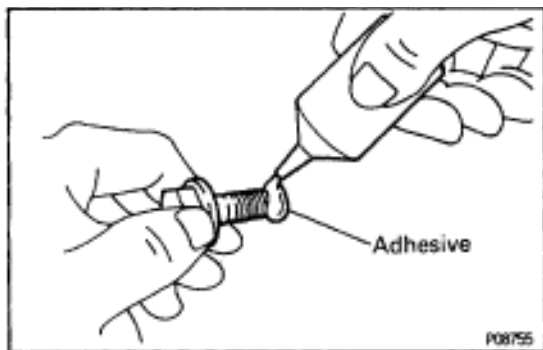

- (b) Apply adhesive to 2 or 3 threads of the mounting bolt end.

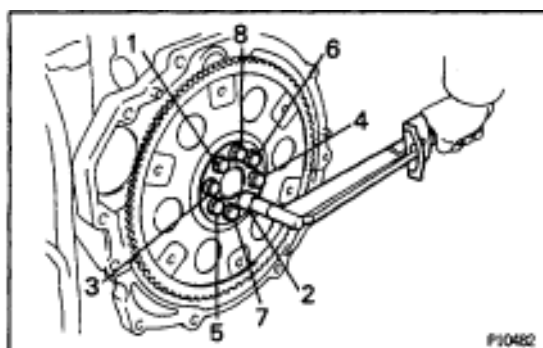

- (c) Install and uniformly tighten the 8 bolts, in several passes, in the sequence shown.

Torque: 83 N·m (850 kgf·cm, 61 ft·lbf)

ENGINE & TRANSMISSION ASSEMBLY

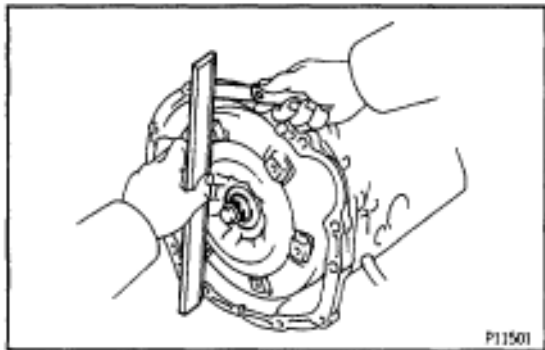

1. A/T:

CHECK TORQUE CONVERTER CLUTCH INSTALLATION
Using calipers and straight edge, measure from the installed surface of the torque converter clutch to the front surface of the transmission.

Correct distance:

Less than 0.1 mm (0.004 in.)

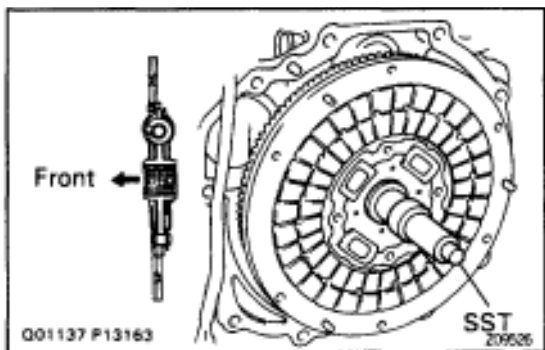

If the distance is not as specified, check for an improper installation.

2. 2JZ-GE M/T:

INSTALL CLUTCH DISC AND COVER

- (a) Insert SST in the clutch disc, and then set them and the cover in position.

SST 09301-00110

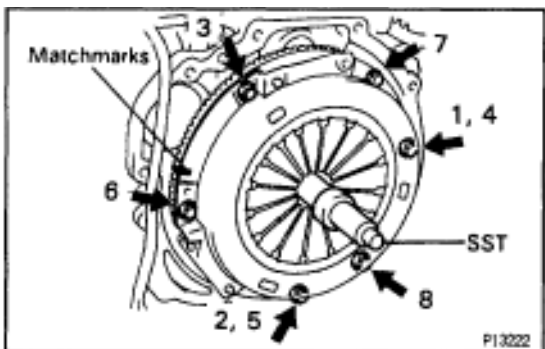

- (b) Align the matchmarks on the clutch cover and flywheel.

- (c) Tighten the bolts evenly and gradually while pushing SST. Make several passes around the cover until it is snug.
SST 09301-00110

- (d) Torque the bolts on the clutch cover in the order shown.

Torque: 19 N·m (195 kgf·cm, 14 ft·lbf)

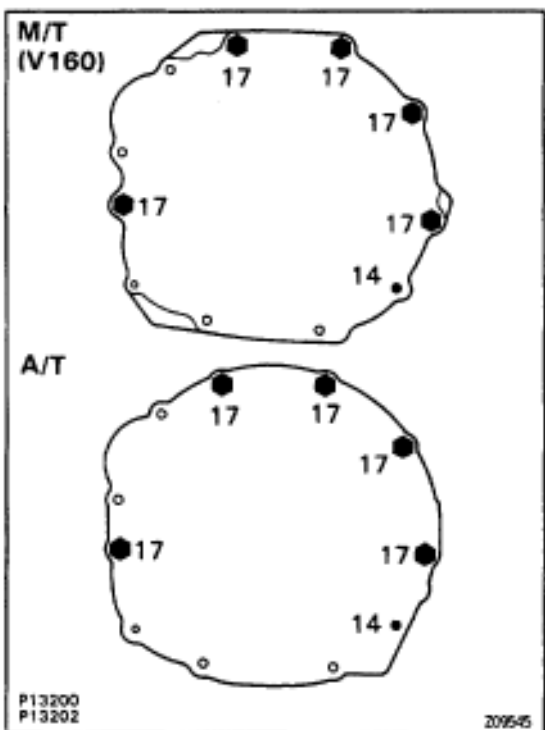

3. ASSEMBLE ENGINE AND TRANSMISSION

- (a) M/T:

Align the input spline with the clutch disc and install the transmission to the engine.

- (b) Align the 2 knock pins on the cylinder block with the pin holes of the clutch housing.

- (c) Install the transmission with the 6 bolts.

Torque:

14 mm head

39 N·m (400 kgf·cm, 29 ft·lbf)

17 mm head

72 N·m (730 kgf·cm, 43 ft·lbf)

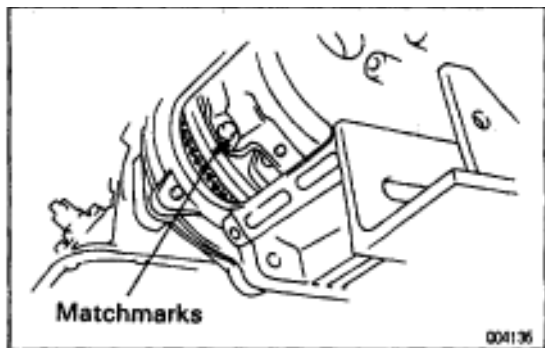

- 4. 2JZ-GTE M/T:
INSTALL CLUTCH COVER SET BOLTS**
- Align the matchmarks.
 - Install the 6 bolts while turning the crankshaft to gain access. Tighten the bolts evenly.
Torque: 19 N·m (195 kgf·cm, 14 ft·lbf)
 - Install the service hole cover with the 2 bolts.
Torque: 12 N·m (120 kgf·cm, 9 ft·lbf)

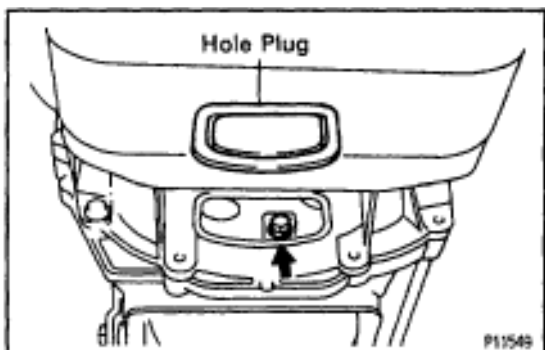

- 5. A/T:
INSTALL TORQUE CONVERTER CLUTCH MOUNTING BOLTS**
- First, install the gray bolt. Then install 5 black bolts while turning the crankshaft to gain access. Tighten the bolts evenly.
Torque: 33 N·m (340 kgf·cm, 25 ft·lbf)
 - Install the hole plug.
- 6. 2JZ-GE A/T:
CONNECT THROTTLE CABLE**
- 7. A/T:
INSTALL OIL COOLER TUBES FOR TRANSMISSION**
- Temporarily install the 2 oil cooler tubes, 2 hose clamps and tube clamp with 3 clamp bolts.
 - Connect the 2 oil cooler tubes to the unions on the transmission. Tighten the union nuts.
Torque: 34 N·m (350 kgf·cm, 25 ft·lbf)
 - Tighten the 3 clamp bolts.
- 8. INSTALL STARTER**
- 9. CONNECT ENGINE WIRE TO TRANSMISSION**
- 10. A/T:
INSTALL OIL DIPSTICK GUIDE AND DIPSTICK FOR TRANSMISSION**
- Install a new O-ring to the dipstick guide.
 - Apply soapy water to the O-ring.
 - Connect the dipstick guide end to the dipstick tube of the oil pan.
 - Install the dipstick guide with the bolt.
 - Install the dipstick.

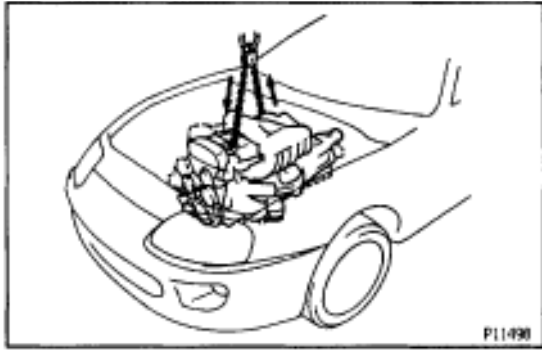

ENGINE INSTALLATION (2JZ-GE)

1. INSTALL ENGINE AND TRANSMISSION ASSEMBLY IN VEHICLE

- (a) Attach the engine hoist chain to the engine hangers.
- (b) Lower the engine and transmission assembly into the engine compartment.

NOTICE: Install the engine and transmission assembly carefully without damaging the shift lever retainer (M/T), A/C compressor and PS solenoid valve.

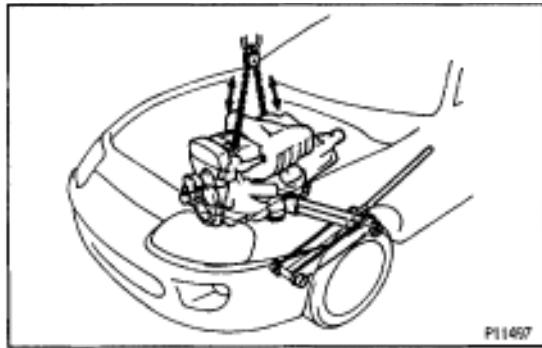

- (c) Insert the stud bolts of the front engine mounting insulators into the stud bolt holes of the front suspension crossmember.
- (d) Temporarily install the 2 nuts holding the engine front mounting insulators to the front suspension crossmember.
- (e) Keep the engine level with a jack.
- (f) Remove the hoist chain.

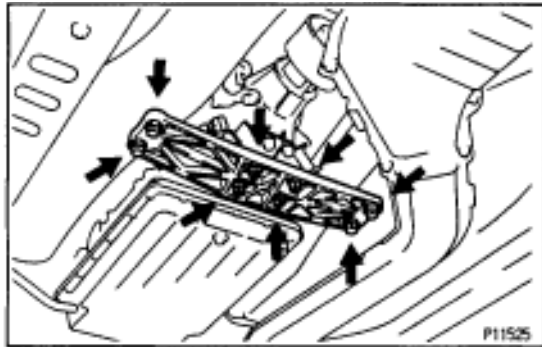

- (g) Temporarily install the support member to the engine rear mounting insulator with the 4 nuts.
- (h) Install the 4 bolts holding the support member to the body.
Torque: 25 N·m (260 kgf·cm, 19 ft·lbf)
- (i) Tighten the 4 nuts holding the support member to the engine rear mounting insulator.
Torque: 13 N·m (135 kgf·cm, 10 ft·lbf)

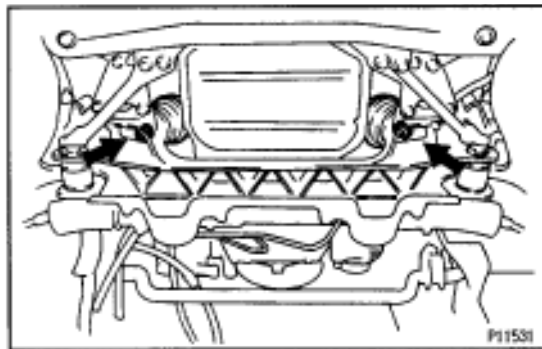

- (j) Tighten the 2 nuts holding the engine front mounting insulators to the front suspension crossmember.
Torque: 59 N·m (600 kgf·cm, 43 ft·lbf)

2. M/T: INSTALL TRANSMISSION SHIFT LEVER

Torque: 19 N·m (195 kgf·cm, 14 ft·lbf)

3. INSTALL PROPELLER SHAFT

(See propeller shaft installation in Propeller Shaft)

4. A/T: CONNECT TRANSMISSION CONTROL ROD

- (a) Shift the shift lever to N position.
- (b) Fully turn the control shaft lever back and return 2 notches. It is now in neutral position.
- (c) Connect the control rod to the shift lever with the nut.
Torque: 13 N·m (130 kgf·cm, 9 ft·lbf)

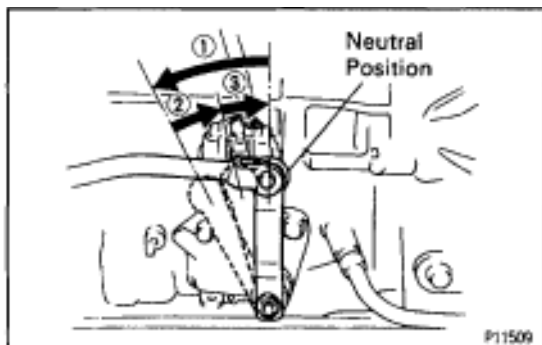

5. INSTALL EXHAUST PIPE HEAT INSULATOR**6. INSTALL NO.2 FRONT EXHAUST PIPE**

- (a) Install 2 new gaskets and the No.2 front exhaust pipe to the exhaust manifold with 4 new nuts.

Torque: 62 N·m (630 kgf·cm, 46 ft·lbf)

- (b) Install the pipe support bracket with the 2 bolts.

Torque: 43 N·m (440 kgf·cm, 32 ft·lbf)

- (c) Install a new gasket and the No.2 front exhaust pipe to the front exhaust pipe with the 2 bolts and 2 new nuts.

Torque: 58 N·m (590 kgf·cm, 43 ft·lbf)

7. M/T:**INSTALL CLUTCH RELEASE CYLINDER AND GROUND STRAP**

- (a) Install the clutch release cylinder with the 2 bolts.

Torque: 13 N·m (130 kgf·cm, 9 ft·lbf)

- (b) Install the ground strap with the bolt.

Torque: 37 N·m (380 kgf·cm, 27 ft·lbf)

8. M/T:**INSTALL UPPER CONSOLE PANEL, SHIFT LEVER BOOTS AND HOLDING BOLTS****9. CONNECT ENGINE WIRE TO CABIN**

- (a) Push in the engine wire through the cowl panel.

NOTICE: Be careful not to damage the engine wire.

- (b) Connect the connector to the connector cassette.

- (c) Connect the connector to the instrument panel wire connector.

- (d) Connect the 2 connectors to the ECM.

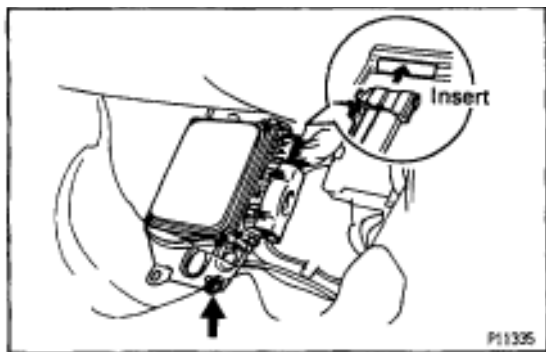

- (e) Insert the ECM bracket into the stay on the floor panel.

- (f) Install the ECM with the nut.

- (g) Install the ECM protector with the 2 nuts.

- (h) Install the floor carpet.

- (i) Install the scuff plate.

10. CONNECT ENGINE WIRE TO COWL PANEL**11. INSTALL A/C COMPRESSOR**

- (a) Using a torx socket (E10), install the stud bolt and compressor.

Torque: 26 N·m (265 kgf·cm, 19 ft·lbf)

- (b) Connect the compressor connector.

- (c) Temporarily install the compressor with the nut and 2 bolts.

- (d) Alternately tighten the nut and 2 bolts.

Torque: 52 N·m (530 kgf·cm, 38 ft·lbf)

12. INSTALL PS PRESSURE TUBE

- Install the pressure tube with the 2 clamp bolts.

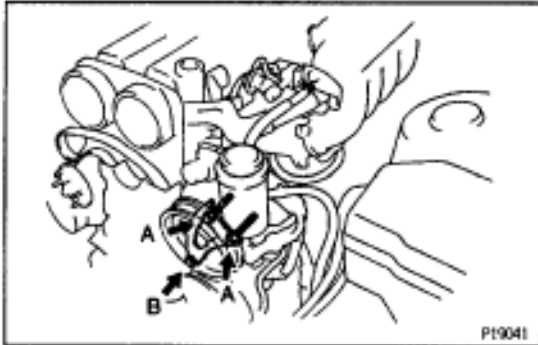
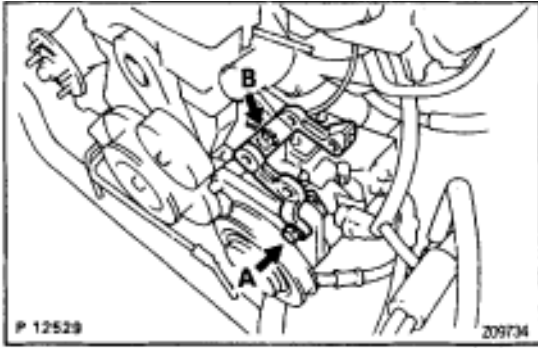

13. INSTALL PS PUMP

- (a) Install the pump bracket with the 2 bolts.

Torque:

A 58 N·m (590 kgf·cm, 43 ft·lbf)

B 39 N·m (400 kgf·cm, 29 ft·lbf)

- (b) Install the pump rear stay with the 2 bolts.
Torque: 39 N·m (400 kgf·cm, 29 ft·lbf)
- (c) Install the pump housing to the pump bracket.
- (d) Connect the following hoses:
- Air hose to No.4 timing belt cover
 - Air hose to air intake chamber
- (e) Install the front pump bracket with the 2 bolts (A).
Torque: 58 N·m (590 kgf·cm, 43 ft·lbf)
- (f) Install the plate washer and bolt (B) to the oil pump.
Torque: 52 N·m (530 kgf·cm, 38 ft·lbf)

14. INSTALL ENGINE WIRE BRACKET

15. CONNECT FUEL HOSES

- (a) Connect the fuel return hose to the fuel return pipe.
- (b) Install the fuel return hose to the clamp of the oil dipstick guide.
- (c) Install the fuel inlet hose with 2 new gaskets and the union bolt.

Torque: 29 N·m (300 kgf·cm, 22 ft·lbf)

16. CONNECT WIRES AND CONNECTORS

17. CONNECT EVAP HOSE

18. CONNECT BRAKE BOOSTER VACUUM HOSE

19. CONNECT HEATER HOSES

20. INSTALL CHARCOAL CANISTER

21. INSTALL WATER PUMP PULLEY, FAN, FLUID COUPLING ASSEMBLY AND DRIVE BELT

(See step 10 in water pump installation in Cooling System)

22. INSTALL AIR CLEANER, VAF METER AND INTAKE AIR CONNECTOR PIPE ASSEMBLY

23. CONNECT CONTROL CABLES TO THROTTLE BODY

24. FILL WITH FUEL

25. FILL WITH ENGINE OIL

26. CHECK IGNITION TIMING

(See ignition timing inspection and adjustment)

27. INSTALL RADIATOR ASSEMBLY

(See radiator installation in Cooling System)

28. START ENGINE AND CHECK FOR LEAKS

29. INSTALL HOOD

30. ROAD TEST VEHICLE

Check for abnormal noise, shock slippage, correct shift points and smooth operation.

31. RECHECK ENGINE COOLANT AND ENGINE OIL LEVELS

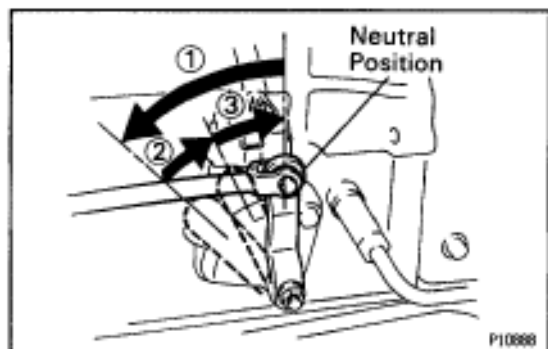
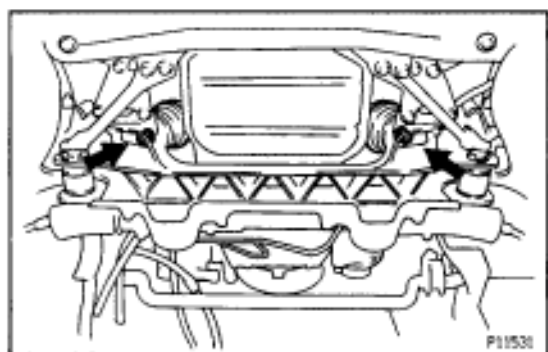
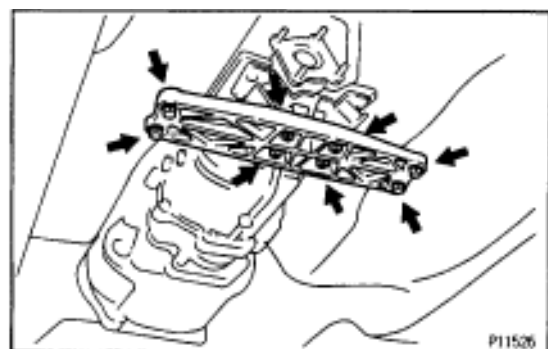
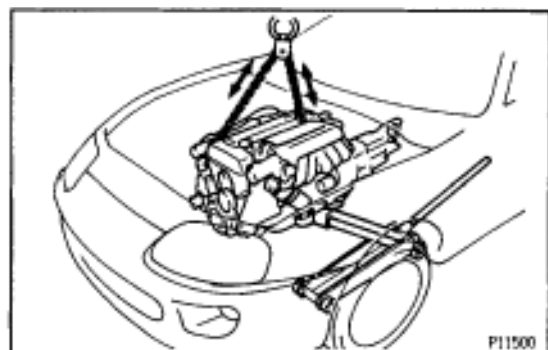
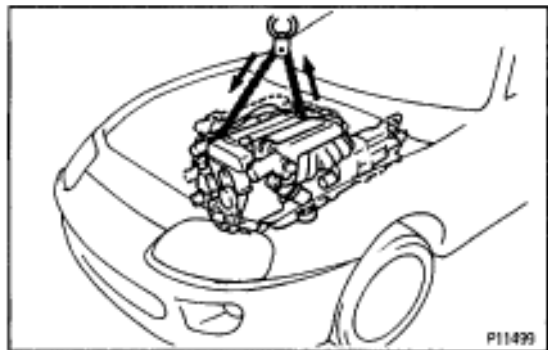

ENGINE INSTALLATION (2JZ-GTE)

1. INSTALL ENGINE AND TRANSMISSION ASSEMBLY IN VEHICLE

- (a) Attach the engine hoist chain to the engine hangers.
- (b) Lower the engine and transmission assembly into the engine compartment.

NOTICE: Install the engine and transmission assembly carefully without damaging the shift lever retainer (M/T), A/C compressor and PS solenoid valve.

- (c) Insert the stud bolts of the front engine mounting insulators into the stud bolt holes of the front suspension crossmember.
- (d) Temporarily install the 2 nuts holding the engine front mounting insulators to the front suspension crossmember.
- (e) Keep the engine level with a jack.
- (f) Remove the hoist chain.

- (g) Temporarily install the support member to the engine rear mounting insulator with the 4 nuts.

- (h) Install the 4 bolts holding the support member to the body.

Torque: 25 N·m (260 kgf·cm, 19 ft·lbf)

- (i) Tighten the 4 nuts holding the support member to the engine rear mounting insulator.

Torque: 13 N·m (135 kgf·cm, 10 ft·lbf)

- (j) Tighten the 2 nuts holding the engine front mounting insulators to the front suspension crossmember.

Torque: 59 N·m (600 kgf·cm, 43 ft·lbf)

2. M/T:

INSTALL TRANSMISSION SHIFT LEVER

Torque: 19 N·m (195 kgf·cm, 14 ft·lbf)

3. A/T:

CONNECT TRANSMISSION CONTROL ROD

- (a) Shift the shift lever to N position.
- (b) Fully turn the control shaft lever back and return 2 notches. It is now in neutral position.

- (c) Connect the control rod to the shift lever with the nut.

Torque: 13 N·m (130 kgf·cm, 9 ft·lbf)

4. INSTALL PROPELLER SHAFT

(See propeller shaft installation in Propeller Shaft)

5. INSTALL REAR CENTER FLOOR CROSSMEMBER BRACE

Torque: 28 N·m (290 kgf·cm, 21 ft·lbf)

6. INSTALL EXHAUST PIPE HEAT INSULATOR

7. INSTALL NO.2 FRONT EXHAUST PIPE

Install a new gasket and the front exhaust pipe with 3 new nuts.

Torque: 62 N·m (630 kgf·cm, 46 ft·lbf)

8. INSTALL EXHAUST PIPE ASSEMBLY

(a) Install the hook of the tailpipe to the 2 rings on the tailpipe bracket.

(b) Install the hook of the exhaust pipe to the 2 rings on the exhaust pipe brackets.

(c) Install the pipe support bracket with the 2 bolts.

Torque: 43 N·m (440 kgf·cm, 32 ft·lbf)

(d) Install a new gasket and the No.2 front exhaust pipe to the front exhaust pipe with the 2 bolts and 2 new nuts.

Torque: 58 N·m (590 kgf·cm, 43 ft·lbf)

9. INSTALL SUB HEATED OXYGEN SENSOR

Install a new gasket, the oxygen sensor and sensor cover with the 2 nuts.

Torque: 18 N·m (180 kgf·cm, 13 ft·lbf)

10. M/T:

INSTALL CLUTCH RELEASE CYLINDER AND GROUND STRAP

(a) Install the clutch release cylinder with the 2 bolts.

Torque: 13 N·m (130 kgf·cm, 9 ft·lbf)

(b) Connect the clutch line tube with the bolt.

Torque: 37 N·m (380 kgf·cm, 27 ft·lbf)

(c) Install the ground strap with the bolt.

Torque: 37 N·m (380 kgf·cm, 27 ft·lbf)

11. CONNECT ENGINE WIRE TO CABIN

(a) Push in the engine wire through the cowl panel.

NOTICE: Be careful not to damage the engine wire.

(b) Connect the 2 connectors to the connector cassette.

(c) Connect the connector to the instrument panel wire connector.

(d) Connect the 2 connectors to the ECM.

(e) Connect the connector to the TRAC ECU.

(f) Insert the ECM bracket into the stay on the floor panel.

(g) Install the ECM with the nut.

(h) Install the ECM protector with the 2 nuts.

(i) Install the floor carpet.

(j) Install the scuff plate.

12. M/T:

INSTALL UPPER CONSOLE PANEL, SHIFT LEVER BOOTS AND HOLDING BOLTS

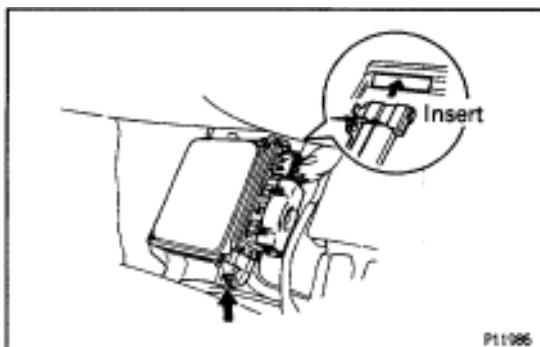

13. CONNECT ENGINE WIRE TO COWL PANEL**14. INSTALL A/C COMPRESSOR**

- (a) Using a torx socket (E10), install the stud bolt and and compressor.

Torque: 26 N·m (265 kgf·cm, 19 ft·lbf)

- (b) Connect the compressor connector.
 (c) Temporarily install the compressor with nut and 3 bolts.
 (d) Alternately tighten the bolt and nut.

Torque: 52 N·m (530 kgf·cm, 38 ft·lbf)

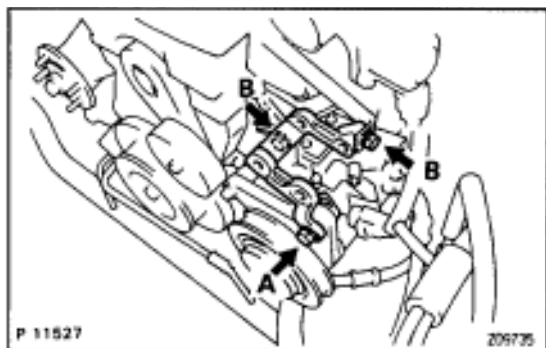
**15. INSTALL PS PRESSURE TUBE****16. INSTALL PS PUMP**

- (a) Install the pump bracket with the 3 bolts.

Torque:

A 58 N·m (590 kgf·cm, 43 ft·lbf)

B 39 N·m (400 kgf·cm, 29 ft·lbf)

- (b) Install the pump housing with the 2 bolts.

Torque: 58 N·m (590 kgf·cm, 43 ft·lbf)

- (c) Connect these hoses:

- Air hose to throttle body
- Air hose to air intake chamber

17. CONNECT FUEL HOSES

- (a) Connect the fuel return hose to the fuel return pipe.
 (b) Install the fuel return hose to the clamp of the dipstick guide.
 (c) Install the fuel inlet hose with 2 new gaskets and the union bolt.

Torque: 29 N·m (300 kgf·cm, 22 ft·lbf)

18. CONNECT WIRES AND CONNECTORS**19. CONNECT EVAP HOSE****20. CONNECT BRAKE BOOSTER VACUUM HOSE****21. CONNECT HEATER WATER HOSES****22. INSTALL CHARCOAL CANISTER****23. INSTALL WATER PUMP PULLEY, FAN, FLUID COUPLING ASSEMBLY AND DRIVE BELT**

(See step 10 in water pump installation in Cooling System)

24. M/T:**INSTALL DRIVE BELT TENSIONER DAMPER**

(See step 19 timing belt installation)

25. INSTALL AIR CLEANER AND MAF METER ASSEMBLY**26. INSTALL NO.1 AIR HOSE****27. CONNECT CONTROL CABLES TO THROTTLE BODY****28. FILL WITH FUEL****29. FILL WITH ENGINE OIL****30. START ENGINE AND CHECK FOR LEAKS**

- 31. CHECK IGNITION TIMING**
(See ignition timing inspection)
- 32. INSTALL RADIATOR ASSEMBLY**
(See radiator installation in Cooling System)
- 33. INSTALL HOOD**
- 34. ROAD TEST VEHICLE**
Check for abnormal noise, shock slippage, correct shift points and smooth operation.
- 35. RECHECK ENGINE COOLANT AND ENGINE OIL LEVELS**

EXHAUST SYSTEM COMPONENTS

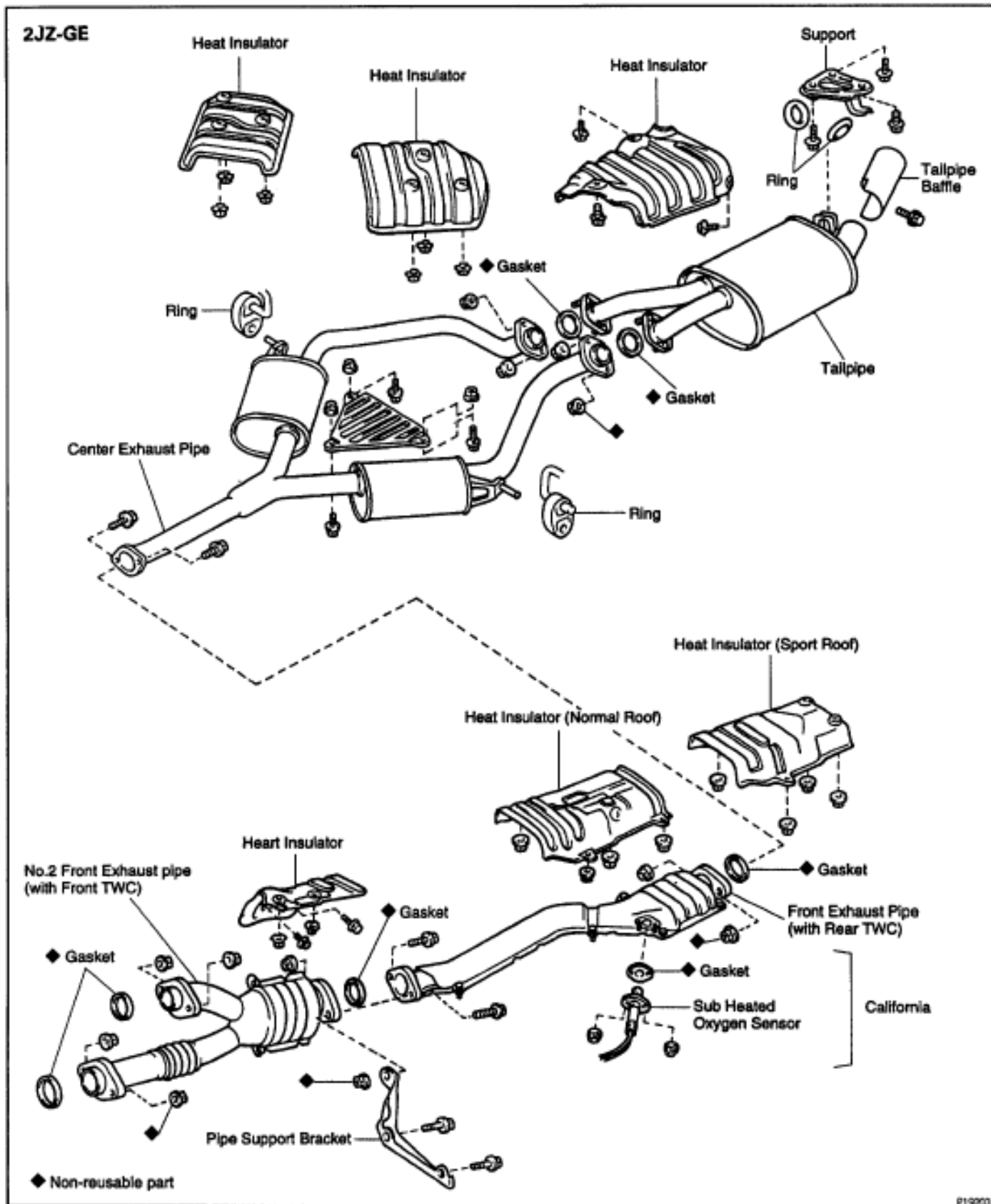

2JZ-GTE

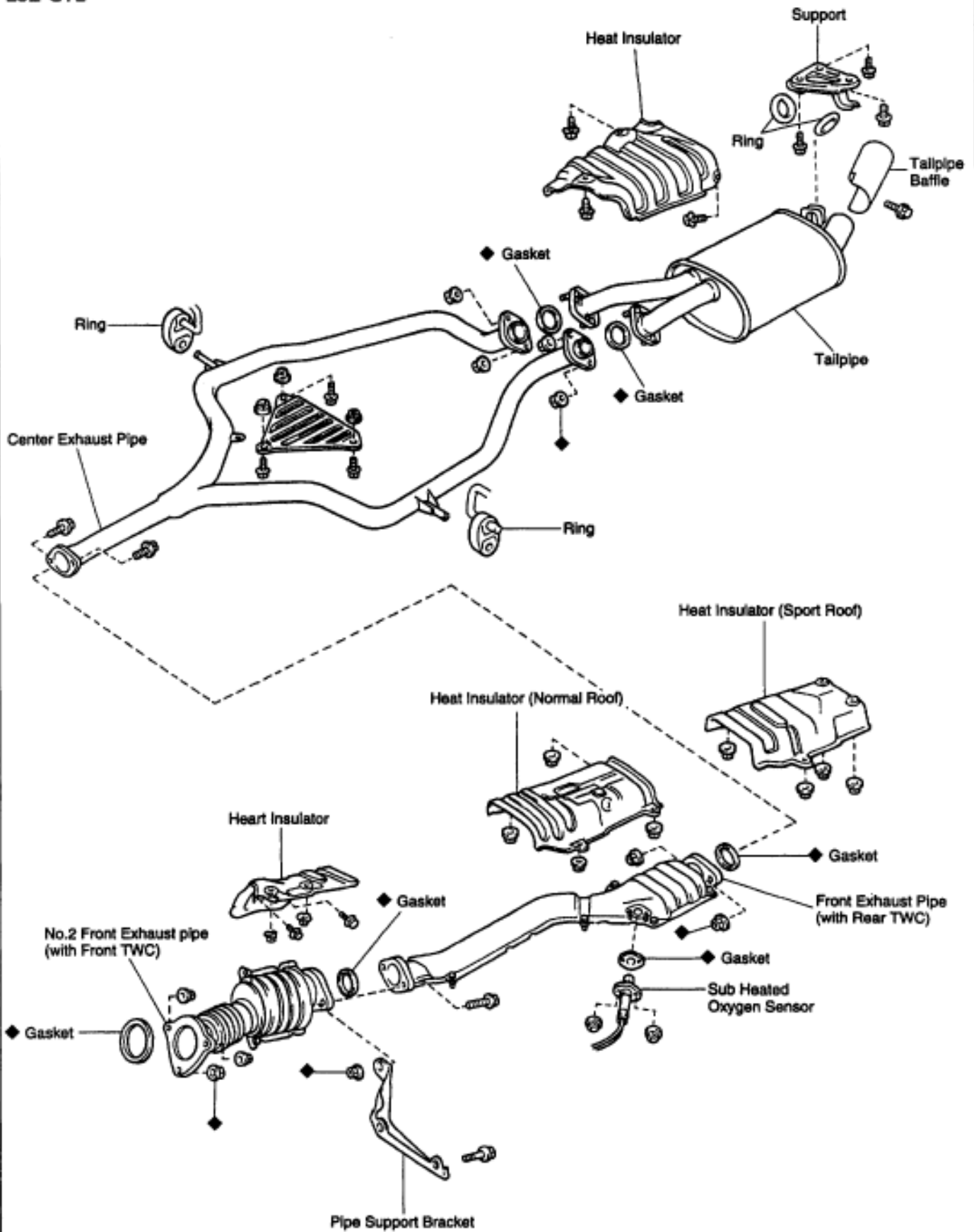

◆ Non-reusable part

SERVICE SPECIFICATIONS

SERVICE DATA

Compression pressure	at 250 rpm STD 2JZ-GE 2JZ-GTE Minimum 2JZ-GE 2JZ-GTE Difference of pressure between each cylinder	1,275 kPa (13.0 kgf/cm ² , 185 psi) or more 1,079 kPa (11.0 kgf/cm ² , 156 psi) or more 1,079 kPa (11.0 kgf/cm ² , 156 psi) 883 kPa (9.0 kgf/cm ² , 128 psi) 98 kPa (1.0 kgf/cm ² , 14 psi) or less	
Valve clearance	at cold Intake Exhaust Adjusting shim (for repair part) Mark 2500 Mark 2.550 Mark 2.600 Mark 2.650 Mark 2.700 Mark 2.750 Mark 2.800 Mark 2.850 Mark 2.900 Mark 2.950 Mark 3.000 Mark 3.050 Mark 3.100 Mark 3.150 Mark 3.200 Mark 3.250 Mark 3.300	0.15-0.25 mm (0.006-0.010 in.) 0.25-0.35 mm (0.010-0.014 in.) 2.500 mm (0.0984 in.) 2.550 mm (0.1004 in.) 2.600 mm (0.1024 in.) 2.650 mm (0.1043 in.) 2.700 mm (0.1063 in.) 2.750 mm (0.1083 in.) 2.800 mm (0.1102 in.) 2.850 mm (0.1122 in.) 2.900 mm (0.1142 in.) 2.950 mm (0.1161 in.) 3.000 mm (0.1181 in.) 3.050 mm (0.1201 in.) 3.100 mm (0.1220 in.) 3.150 mm (0.1240 in.) 3.200 mm (0.1260 in.) 3.250 mm (0.1280 in.) 3.300 mm (0.1299 in.)	
Ignition timing	w/ Terminals TE1 and E1 connected of DLC1	10° BTDC @ idle	
Idle speed	2JZ-GE 2JZ-GTE	700 ± 50 rpm 650 ± 50 rpm	
Intake Manifold Vacuum	at idle speed 2JZ-GE 2JZ-GTE	66.6 kPa (500 mmHg, 19.7 in.Hg) or more 60 kPa (450 mmHg, 17.7 in.Hg) or more	
Timing belt Tensioner	Protrusion (from housing side)	8.0-8.8 mm (0.315-0.346 in.)	
Cylinder head	Warpage Cylinder block side Intake manifold side Exhaust manifold side Valve guide bore diameter Valve seat Refacing angle Contacting angle Contacting width Cylinder head bolt diameter	Maximum Maximum Maximum STD O/S 0.05 Intake Exhaust STD Minimum	0.10 mm (0.0039 in.) 0.10 mm (0.0039 in.) 0.10 mm (0.0039 in.) 10.985-11.006 mm (0.4325-0.4333 in.) 11.035-11.056 mm (0.4344-0.4353 in.) 15°, 45°, 60° 45° 1.0-1.4 mm (0.039-0.055 in.) 1.2-1.6 mm (0.047-0.063 in.) 10.8-11.0 mm (0.425-0.433 in.) 10.7 mm (0.421 in.)

Valve guide Bushing	Inside diameter		6.010–6.030 mm (0.2366–0.2374 in.)
		Outside diameter (for repair part)	STD 11.033–11.044 mm (0.4344–0.4348 in.)
		O/S 0.05	11.083–11.094 mm (0.4363–0.4368 in.)
Valve	Valve overall length	STD Intake	98.29–98.79 mm (3.8697–3.8894 in.)
		Exhaust	98.84–99.34 mm (3.8913–3.9110 in.)
	Minimum Intake		98.19 mm (3.8657 in.)
		Exhaust	98.74 mm (3.8874 in.)
	Valve face angle		44.5°
	Stem diameter	Intake	5.970–5.985 mm (0.2350–0.2356 in.)
		Exhaust	5.965–5.980 mm (0.2348–0.2354 in.)
	Stem oil clearance	STD Intake	0.025–0.060 mm (0.0010–0.0024 in.)
		Exhaust	0.030–0.065 mm (0.0012–0.0026 in.)
	Margin thickness	Maximum Intake	0.08 mm (0.0031 in.)
		Exhaust	0.10 mm (0.0039 in.)
		STD	0.8–1.2 mm (0.031–0.047 in.)
	Minimum	0.5 mm (0.020 in.)	
Valve spring	Deviation	Maximum	2.0 mm (0.079 in.)
	Free length	Blue painted mark	41.74 mm (1.6433 in.)
		Yellow painted mark	41.70 mm (1.6417 in.)
	Installed tension at 34.5 mm (1.358 in.)		186–206 N (19.0–21.0 kgf, 42–46 lbf)
Valve lifter	Lifter diameter		30.966–30.976 mm (1.2191–1.2195 in.)
	Lifter bore diameter		31.000–31.016 mm (1.2205–1.2211 in.)
	Oil clearance	STD	0.024–0.050 mm (0.0009–0.0020 in.)
Maximum		0.07 mm (0.0028 in.)	
Camshaft	Thrust clearance	STD	0.080–0.190 mm (0.0031–0.0075 in.)
		Maximum	0.30 mm (0.0118 in.)
	Cam lobe height	STD Intake	44.570–44.670 mm (1.7547–1.7587 in.)
		Exhaust	44.770–44.870 mm (1.7626–1.7665 in.)
	Maximum Intake		44.42 mm (1.7488 in.)
		Exhaust	44.62 mm (1.7567 in.)
	Journal diameter		28.949–28.965 mm (1.1397–1.1404 in.)
Journal oil clearance	STD	0.035–0.072 mm (0.0014–0.0028 in.)	
	Maximum	0.10 mm (0.0039 in.)	
Circle runout	Maximum	0.08 mm (0.0031 in.)	
Air intake chamber	Warpage	Maximum	0.15 mm (0.0059 in.)
Manifold	Warpage	Maximum Intake	0.15 mm (0.0059 in.)
		Exhaust 2JZ–GE	0.50 mm (0.0196 in.)
		2JZ–GTE	0.80 mm (0.0315 in.)
Cylinder block	Cylinder head surface warpage	Maximum	0.07 mm (0.0028 in.)
		STD	86.000–86.013 mm (3.3858–3.3863 in.)
	Cylinder bore diameter	Maximum	86.02 mm (3.3866 in.)
		STD	9.96–9.97 mm (0.3921–0.3925 in.)
Main bearing bolt diameter	STD	9.96–9.97 mm (0.3921–0.3925 in.)	
	Minimum	9.7 mm (0.382 in.)	
Connecting Rod	Thrust clearance	STD	0.250–0.402 mm (0.0098–0.0158 in.)
		Maximum	0.50 mm (0.0197 in.)
	Connecting bolt diameter	STD	8.1–8.3 mm (0.319–0.327 in.)
		Minimum	8.0 mm (0.315 in.)

Connecting rod (cont'd)	Connecting rod oil clearance	STD STD	0.035–0.053 mm (0.0014–0.0021 in.)
		U/S 0.25	0.040–0.078 mm (0.0016–0.0031 in.)
	Maximum STD	U/S 0.25	0.08 mm (0.0031 in.)
		U/S 0.25	0.09 mm (0.0035 in.)
	Connecting rod bearing center wall thickness (Reference)	STD Mark 1	1.492–1.495 mm (0.0587–0.0589 in.)
		Mark 2	1.495–1.498 mm (0.0589–0.0590 in.)
		Mark 3	1.498–1.501 mm (0.0590–0.0591 in.)
		Mark 4	1.501–1.504 mm (0.0591–0.0592 in.)
		Mark 5	1.504–1.507 mm (0.0592–0.0593 in.)
	Bushing inside diameter		22.005–22.014 mm (0.8663–0.8667 in.)
Piston pin diameter		21.997–22.006 mm (0.8660–0.8664 in.)	
Piston pin oil clearance	STD	0.005–0.011 mm (0.0002–0.0004 in.)	
	Maximum	0.05 mm (0.0020 in.)	
Rod bent	Maximum per 100 mm (3.94 in.)	0.05 mm (0.0020 in.)	
Rod twist	Maximum per 100 mm (3.94 in.)	0.15 mm (0.0059 in.)	
Piston and Piston ring (2JZ-GE)	Piston diameter		85.935–85.945 mm (3.3833–3.3837 in.)
	Piston oil clearance	STD	0.055–0.078 mm (0.0022–0.0031 in.)
		Maximum	0.10 mm (0.0039 in.)
	Piston ring groove clearance	No.1	0.011–0.070 mm (0.0004–0.0028 in.)
		No.2	0.030–0.070 mm (0.0012–0.0028 in.)
	Piston ring end gap	STD No.1	0.300–0.470 mm (0.0118–0.0185 in.)
		No.2	0.350–0.520 mm (0.0138–0.0205 in.)
		Oil	0.130–0.450 mm (0.0051–0.0177 in.)
		Maximum No.1	1.07 mm (0.0421 in.)
No.2		1.12 mm (0.0441 in.)	
Oil	1.05 mm (0.0413 in.)		
Piston and Piston ring (2JZ-GTE)	Piston diameter		85.917–85.927 mm (3.3826–3.3830 in.)
	Piston oil clearance	STD	0.073–0.096 mm (0.0029–0.0038 in.)
		Maximum	0.12 mm (0.0047 in.)
	Piston ring groove clearance	No.1	0.040–0.080 mm (0.0016–0.0031 in.)
		No.2	0.030–0.070 mm (0.0012–0.0028 in.)
	Piston ring end gap	STD No.1	0.300–0.400 mm (0.0118–0.0157 in.)
		No.2	0.350–0.450 mm (0.0138–0.0178 in.)
		Oil	0.130–0.380 mm (0.0051–0.0150 in.)
		Maximum No.1	1.00 mm (0.0394 in.)
No.2		1.05 mm (0.0413 in.)	
Oil	0.98 mm (0.0386 in.)		
Crankshaft	Thrust clearance	STD	0.020–0.220 mm (0.0008–0.0087 in.)
		Maximum	0.30 mm (0.0118 in.)
	Thrust washer thickness	STD	1.940–1.990 mm (0.0764–0.0783 in.)
	Main journal oil clearance	STD STD	0.026–0.040 mm (0.0010–0.0016 in.)
		U/S 0.25	0.025–0.061 mm (0.0010–0.0024 in.)
		Maximum STD	0.06 mm (0.0024 in.)
	Main journal diameter	U/S 0.25	0.08 mm (0.0031 in.)
		STD	61.984–62.000 mm (2.4403–2.4409 in.)
	U/S 0.25	61.745–61.755 mm (2.4309–2.4313 in.)	

Crankshaft (cont'd)	Main bearing center wall thickness (Reference)			
	Mark 1	1.994–1.997 mm (0.0785–0.0786 in.)		
	Mark 2	1.997–2.000 mm (0.0786–0.0787 in.)		
	Mark 3	2.000–2.003 mm (0.0787–0.0789 in.)		
	Mark 4	2.003–2.006 mm (0.0789–0.0790 in.)		
	Mark 5	2.006–2.009 mm (0.0790–0.0791 in.)		
	Crank pin diameter	STD	51.982–52.000 mm (2.0465–2.0472 in.)	
		U/S 0.25	51.745–51.755 mm (2.0372–2.0376 in.)	
	Circle runout	Maximum	0.06 mm (0.0024 in.)	
	Main journal taper and out-of-round	Maximum	0.02 mm (0.0008 in.)	
Crank pin taper and out-of-round	Maximum	0.02 mm (0.0008 in.)		

TORQUE SPECIFICATIONS

Part tightened		N·m	kgf·cm	ft·lbf
Timing belt plate X Oil pump (2JZ–GTE)		7.8	80	69 in.·lbf
Idler pulley X Oil pump		34	350	25
Crankshaft pulley X Crankshaft		324	3,300	239
Camshaft timing pulley X Camshaft		79	810	59
Timing belt tensioner X Oil pump		26	270	20
Drive belt tensioner X Cylinder head		21	210	15
Drive belt tensioner damper X Tensioner arm (2JZ–GTE M/T)		20	200	14
Drive belt tensioner damper X Tensioner bracket (2JZ–GTE M/T)		20	200	14
EGR cooler X Cylinder head		8.8	90	78 in.·lbf
ECT sensor X Cylinder head (2JZ–GE)		20	200	14
ECT sender gauge X Cylinder head (2JZ–GE)		20	200	14
Engine hanger X Cylinder head		39	400	29
Camshaft position sensor X Cylinder head (2JZ–GTE)		8.8	90	78 in.·lbf
Cylinder head X Cylinder block	1st	34	350	25
	2nd	Turn 90°		
	3rd	Turn 90°		
Camshaft bearing cap X Cylinder head		20	200	14
No.4 timing belt cover X Cylinder head		8.8	90	78 in.·lbf
Cylinder head cover X Cylinder head	2JZ–GE	8.3	85	74 in.·lbf
	2JZ–GTE	5.4	55	48 in.·lbf
Intake manifold X Cylinder head	2JZ–GE	27	280	20
	2JZ–GTE	27	280	20
Fuel inlet pipe X Delivery pipe		42	420	30
Intake manifold stay X Intake manifold		39	400	29
Intake manifold stay X Cylinder block		39	400	29
Water outlet X Cylinder head (2JZ–GTE)		21	210	15
Vacuum control valve set X Intake manifold (2JZ–GE)		21	210	15
Air intake chamber X Intake manifold	2JZ–GE	27	280	20
	2JZ–GTE	27	280	20
Air intake chamber stay X Cylinder head (2JZ–GE)		18	185	13
Air intake chamber stay X Air intake chamber (2JZ–GE)		18	185	13
Exhaust manifold X Cylinder head		39	400	29
Pressure tank X Intake manifold (2JZ–GTE)		21	210	15
Main bearing cap X Cylinder block	1st	44	450	33
	2nd	Turn 90°		

Connecting rod cap X Connecting rod	1st 2nd	29 Turn 90°	300	22
Oil nozzle X Crankshaft (2JZ-GTE)		8.8	90	78 in.·lbf
Rear oil seal retainer X Cylinder block		5.9	60	52 in.·lbf
Crankshaft position sensor X Cylinder block (2JZ-GTE)		8.8	90	78 in.·lbf
Engine mounting bracket X Cylinder block		58	590	43
Engine coolant drain plug X Cylinder block		29	300	22
Union for oil cooler X Cylinder block (2JZ-GTE)		39	400	29
Knock sensor X Cylinder block		44	450	33
Oil pressure switch X Cylinder block		14	150	11
Fuel pipe support X Cylinder block		14	145	10
Oil filter bracket X Cylinder block		88	900	65
No.2 water bypass pipe X Water pump		21	210	15
No.2 water bypass pipe X Cylinder block		21	210	15
Flywheel X Crankshaft (M/T)	1st 2nd	49 Turn 90°	500	36
Drive plate X Crankshaft (A/T)		83	850	61
Clutch cover X Flywheel (M/T)		19	195	14
Cylinder block X Transmission	14 mm head	39	400	29
	17 mm head	72	730	43
Clutch service hole cover X Clutch housing (2JZ-GTE M/T)		12	120	9
Drive plate X Torque converter clutch (A/T)		33	340	25
Oil cooler tube X Union for transmission (A/T)		34	350	25
Rear support member X Body		25	260	19
Rear support member X Engine rear mounting insulator		13	135	10
Front suspension crossmember X Engine mounting insulator		59	600	43
Transmission shift lever X Shift lever retainer (M/T)		19	195	14
Transmission control rod X Shift lever (A/T)		13	130	9
Clutch release cylinder X Transmission (M/T)		13	130	9
Clutch line tube X No.1 oil pan		37	380	27
Ground strap X Transmission (M/T)		37	380	27
Fuel inlet hose X Fuel pipe support		29	300	22
A/C compressor X Cylinder block	for stud bolt	26	265	19
	for bolt and nut	52	530	38
PS pump front bracket X Cylinder block (2JZ-GE)		58	590	43
PS pump front bracket X Oil pump (2JZ-GE)		52	530	38
PS pump housing X PS pump bracket		58	590	43
PS pump bracket X A/C compressor		58	590	43
PS pump bracket X Cylinder block		39	400	29
PS pump rear stay X PS pump bracket		39	400	29
PS pump rear stay X Intake manifold stay (2JZ-GE)		39	400	29
Rear center floor crossmember brace X Body (2JZ-GTE)		28	290	21
No.2 front exhaust pipe X Exhaust manifold		62	630	46
No.2 front exhaust pipe X Front exhaust pipe		58	590	43
Pipe support bracket X Transmission		43	440	32
Front exhaust pipe X Center exhaust pipe		58	590	43
Center exhaust pipe X Tailpipe		19	195	14
Sub heated oxygen sensor x Front exhaust pipe (2JZ-GE (California), 2JZ-GTE)		20	200	14