

---

# STEERING

## PRECAUTION

- Care must be taken to replace parts properly because they could affect the performance of the steering system and result in a driving hazard.
- The steering wheel pad has an SRS (Supplemental Restraint System) airbag built in, so take all due precautions when handling it. For more details, see the RS section.













## TROUBLESHOOTING















Use the table below to help you find the cause of the problem. The numbers indicate the priority of the likely cause of the problem. Check each part in order. If necessary, repair or replace these parts.







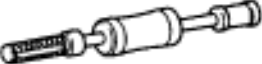

See page	SA-3	SA-4	SR-7	-	-	SA-27 SA-30	-	-	-	SR-49	SR-47	SA-16
Parts Name	Tires (improperly inflated)	Front wheel alignment (Incorrect)	Fluid level (Low)	Drive belt (Loose)	Steering system joints (Worn)	Suspension arm ball joints (Worn)	Steering column (Binding)	Sliding yoke (Worn)	Steering gear housing	Solenoid valve	Electronic control	Front wheel bearing (Worn)
Trouble												
Hard steering	1	4	2	3	5	6	7		10	8	9	
Poor return	1	2					3		4			
Excessive play					1	2		3	5			4
Abnormal noise			1		2				3			

# PREPARATION





## SST (SPECIAL SERVICE TOOLS)

	09608-30012	Front Hub & Drive Pinion Bearing Tool Set	
	(09608-04030)	Front Hub Inner Bearing Cone Replacer	Vane pump shaft
	09612-00012	Rack & Pinion Steering Rack Housing Stand	
	09612-30012	Steering Worm Bearing Puller	Rack housing bearing and oil seal
	09616-00010	Steering worm Bearing Adjusting Socket	Control Valve Shaft
	09620-30010	Steering Gear Box Replacer Set	
	(09624-30010)	Steering Sector Shaft Oil Seal Replacer	Rack housing oil seal
	(09626-30010)	Steering Worm Front Bearing Replacer	Rack housing bearing
	(09627-30010)	Steering Sector Shaft Bushing Replacer	Cylinder end stopper
	(09631-00020)	Handle	
	09630-24013	Steering Rack Oil Seal Tool Set	
	(09620-24010)	Valve Cup Oil Seal Remover	Control valve housing oil seal and bearing
	(09620-24020)	Valve Cup Oil Seal Replacer	Control valve housing oil seal

	(09620-24030) Valve Cup Bearing Replacer	Control valve housing bearing
	09631-10030 Oil Seal Remover	Vane pump front housing oil seal
	09631-12020 Handle	
	09631-12071 Steering Rack Oil Seal Test Tool	
	09631-20031 Oil Seal "B" Remover	Rack housing oil seal and spacer
	09631-20081 Seal Ring Tool	Control valve teflon rings
	09631-20102 Steering Rack Cover "H"	
	09631-22070 Oil Seal Replacer	Rack housing oil seal
	09631-32020 Seal Ring Tool	Hydraulic reaction chamber teflon rings
	09633-00020 Power Steering Hose Nut Wrench	
	09910-00015 Puller Set	
	(09911-00011) Puller Clamp	Tilt No.2 bolt
	(09912-00010) Puller Slide Hammer	Tilt No.2 bolt
	09922-10010 Variable Open Wrench	

	09950-40010 Puller B Set	
	(09957-04010) Attachment	Main shaft assembly
	(09958-04010) Holder	Main shaft assembly
	09950-50010 Puller C Set	
	(09951-05010) Hanger 150	
	(09952-05010) Slide Arm	
	(09953-05020) Center Bolt 150	
	(09954-05020) Claw No.2	
	09960-10010 Variable Pin Wrench Set	Vane pump pulley

## RECOMMENDED TOOLS

	09025-00010 Torque Wrench (30 kgf·cm) ◆	Total preload
	09042-00010 Torx Socket T30 ◆	Steering wheel pad Compression spring
	09082-00050 TOYOTA Electrical Tester Set ◆	
	09905-00012 Snap Ring No.1 Expander ◆	

	09905-00013 Snap ring Pliers ◆	
---	--------------------------------	--

**LUBRICANT**

MOTR-08

Item	Capacity	Classification
Power steering fluid Total	1.0 liters (1.1 US qts, 0.9 Imp.qts)	ATF DEXRON® II

**EQUIPMENT**

MOTR-02

Caliper gauge	PS vane pump
Dial indicator	Steering rack
Feeler gauge	Rotor and vane plate
Micrometer	PS vane pump
Oil pressure gauge	
Pull scale	Steering effort
Torque wrench	
Vacuum gauge	Gear housing

**SSM (SPECIAL SERVICE MATERIALS)**

MOTR-01

08833-00080 Adhesive 1344, THREE BOND 1344, LOCTITE 242 or equivalent	Rack housing cap rack guide spring cap Rack guide spring cap lock nut
---	---

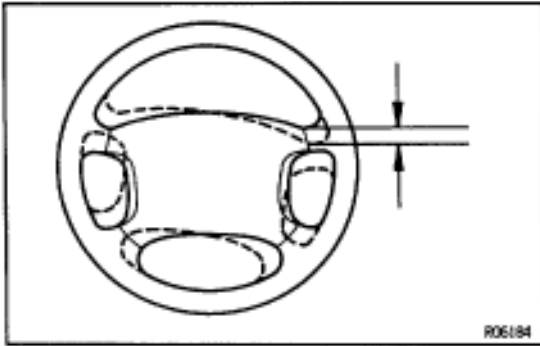

## ON-VEHICLE INSPECTION

### STEERING WHEEL FREEPLAY CHECK

With the vehicle stopped and tires pointed straight ahead, rock the steering wheel gently back and forth with light finger pressure.

Freeplay should not exceed the maximum.

	Freeplay	mm(in.)
Maximum	30	(1.18)

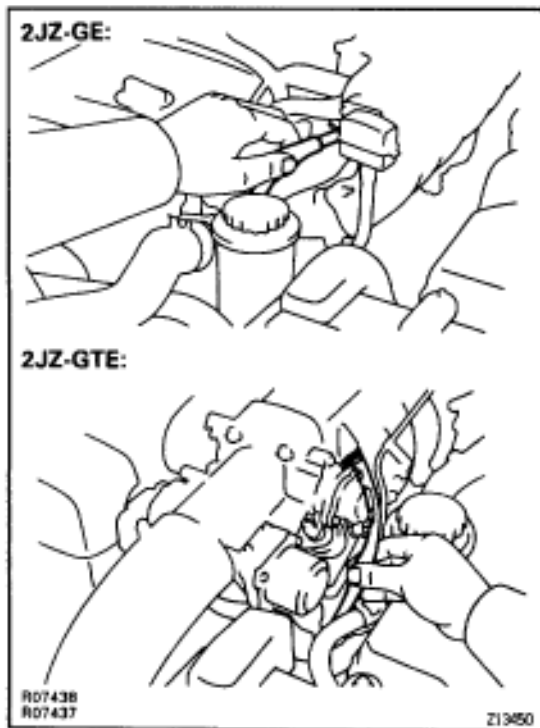

### IDLE-UP CHECK

1. **TURN AIR CONDITIONING SWITCH OFF**
2. **CHECK IDLE-UP**
  - (a) Start engine and run it at idle.
  - (b) Fully turn the steering wheel.
  - (c) Check that the engine speed decreases when the air control valve hose is pinched.
  - (d) Check that the engine speed increases when the hose is released.

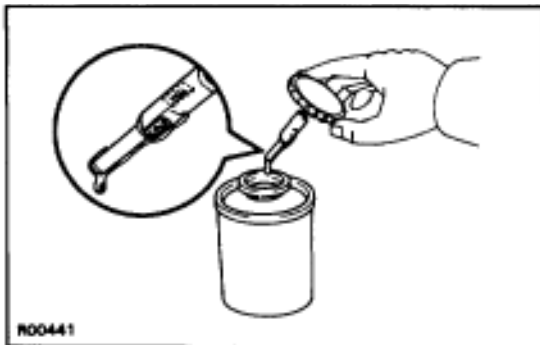

### FLUID LEVEL CHECK

1. **KEEP VEHICLE LEVEL**
2. **CHECK FLUID LEVEL**  
Check the fluid level in the reservoir.  
If necessary, add fluid.

**Fluid:**

**ATF DEXRON® II**

**HINT:** Check that the fluid level is within the HOT LEVEL range on the dipstick of the reservoir cap. If the fluid is cold, check that it is within the COLD LEVEL range.

3. **BOOST FLUID TEMPERATURE**
  - (a) Start the engine and run it at idle.
  - (b) Turn the steering wheel from lock to lock several times to boost fluid temperature.

**Fluid temperature:**

**80°C (176°F)**

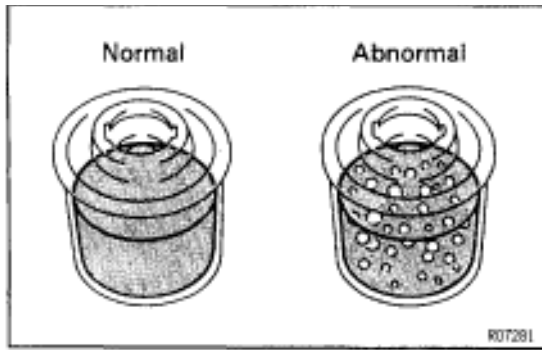

#### 4. CHECK FOR FOAMING OR EMULSIFICATION

If there is foaming or emulsification, bleed power steering system.

(See page [SR-9](#))

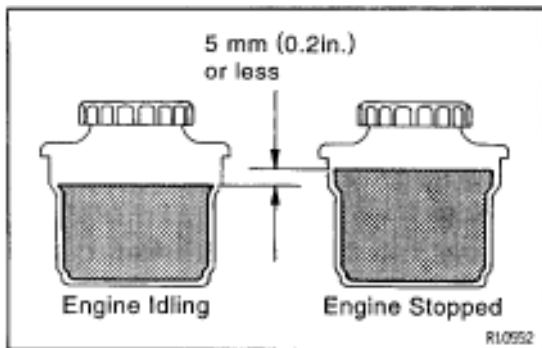

#### 5. CHECK FLUID LEVEL RISE

- With the engine idling, measure the fluid level in the reservoir.
- Stop the engine.
- Wait a few minutes and remeasure the fluid level in the reservoir.

	Fluid level rise	mm (in.)
Maximum	5	(0.2)

If a problem is found, bleed power steering system.

(See page [SR-9](#))

#### 6. CHECK FLUID LEVEL

## POWER STEERING FLUID REPLACEMENT

### 1. JACK UP FRONT OF VEHICLE AND SUPPORT IT WITH STANDS

### 2. DRAIN FLUID

- Disconnect the return hose from the PS vane pump.
- Turn the steering wheel from lock to lock.

### 3. FILL OIL RESERVOIR

- Fill oil reservoir with fresh fluid.

**Fluid:**

**ATF DEXRON® II**

- Start engine.
- After 1 or 2 seconds, fluid will begin to discharge from the return hose.
- Stop the engine immediately.

**NOTICE: Take care that some fluid remains in the oil reservoir.**

- Repeat steps (a), (b), (c) and (d) until there is no more air in fluid.

- Connect the return hose.

### 4. BLEED POWER STEERING SYSTEM

(See page [SR-9](#))



## POWER STEERING SYSTEM BLEEDING

**1. JACK UP FRONT OF VEHICLE AND SUPPORT IT WITH STANDS**

**2. TURN STEERING WHEEL**

With the engine stopped, turn the steering slowly from lock to lock several times.

**NOTICE:** Take care that some fluid remains in the oil reservoir.

**3. LOWER VEHICLE**

**4. START ENGINE**

Run the engine at idle for a few minutes.

**5. TURN STEERING WHEEL**

(a) With the engine at idling, turn the wheel to left or right full lock and keep it there for 2–3 seconds, then turn the wheel to the opposite full lock and keep it there for 2–3 seconds.

(b) Repeat (a) several times.

**6. STOP ENGINE**

**7. CHECK FOR FOAMING OR EMULSIFICATION**

If the system has to be bled twice specifically because of foaming or emulsification, check for fluid leaks in the system.

**8. CHECK FLUID LEVEL**

(See page [SR-7](#))

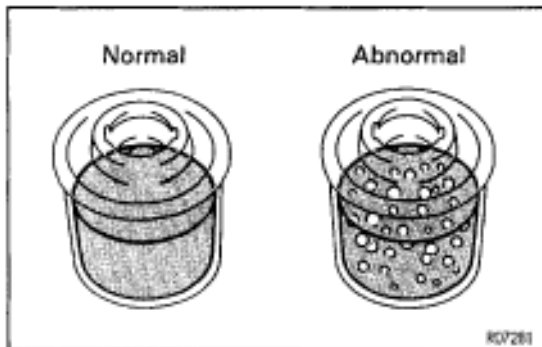

## FLUID PRESSURE CHECK

### 1. CONNECT OIL PRESSURE GAUGE

- Disconnect the pressure feed tube from the PS vane pump. (See page [SR-26](#))

- Connect the gauge over a new gasket, as shown below.  
**NOTICE:** Check that the valve of the gauge is in the open position.

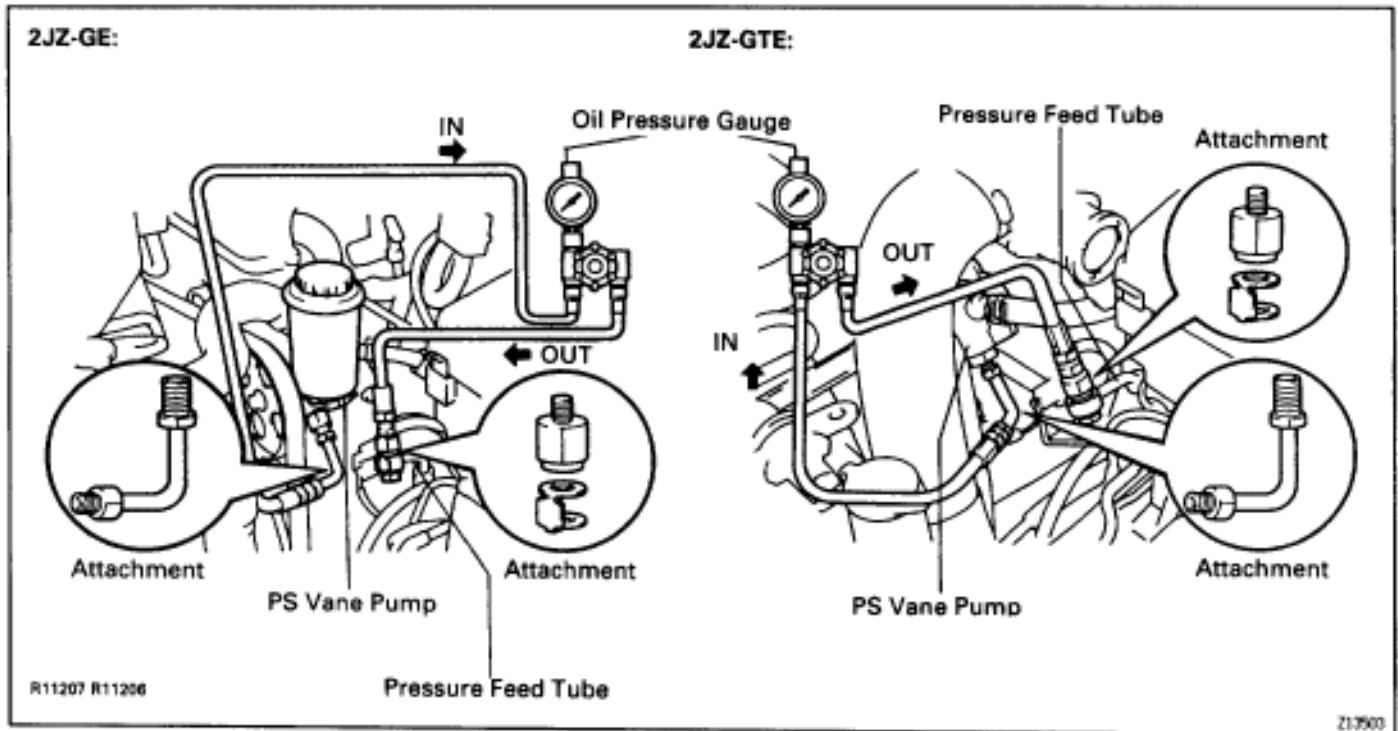

### 2. BLEED POWER STEERING SYSTEM

(See page [SR-9](#))

### 3. BOOST FLUID TEMPERATURE

- Start the engine and run it at idle.
- Turn the steering wheel from lock to lock several times to boost fluid temperature.

**Fluid temperature:**

80°C (176°F)

### 4. CHECK FLUID PRESSURE READING WITH VALVE CLOSED

With the engine idling, close the oil pressure gauge valve and observe the reading on the gauge.

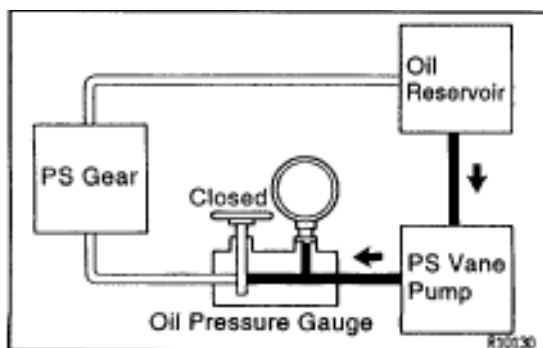

	Fluid pressure	kPa (kgf/cm <sup>2</sup> , psi)
Minimum		7,355 (75, 1,067)

#### **NOTICE:**

- Do not keep the valve closed for more than 10 seconds.
- Do not let the fluid temperature become too high.

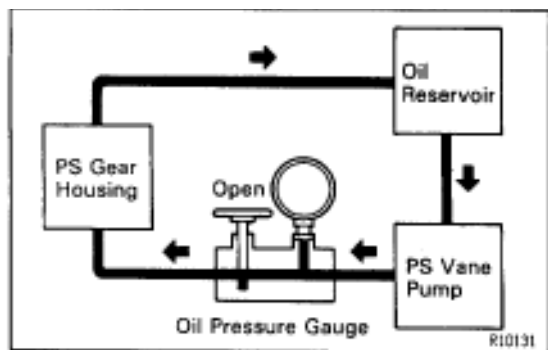

## 5. CHECK FLUID PRESSURE READING WITH VALVE OPENED

- With the engine idling, open the valve fully.
- Measure the fluid pressure at engine speeds of 1,000 rpm and 3,000 rpm.

	Fluid pressure	kPa (kgf/cm <sup>2</sup> , psi)
Difference	490 (5, 71) or less	

**NOTICE:** Do not turn the steering wheel.

## 6. CHECK FLUID PRESSURE READING WITH STEERING WHEEL TURNED TO FULL LOCK

With the engine idling and valve fully opened, turn the wheel to full lock.

	Fluid pressure	kPa (kgf/cm <sup>2</sup> , psi)
Minimum	7,355 (75, 1,067)	

**NOTICE:**

- Do not maintain lock position for more than 10 seconds.
- Do not let the fluid temperature become too high.

## 7. DISCONNECT OIL PRESSURE GAUGE

- Disconnect the pressure gauge.
- Connect the pressure feed tube.  
(See page [SR-32](#))

## 8. BLEED POWER STEERING SYSTEM

(See page [SR-9](#))

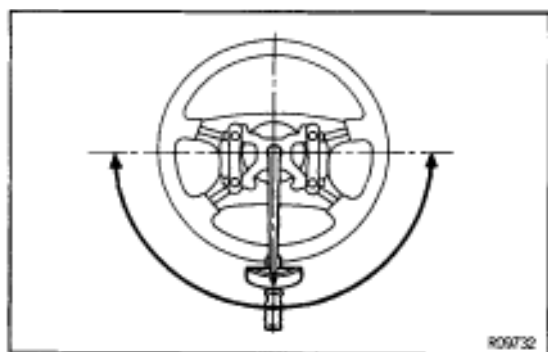
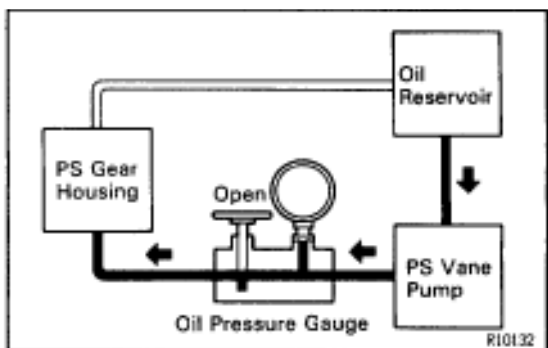

## STEERING EFFORT MEASUREMENT

### 1. CENTER STEERING WHEEL

### 2. MEASURE STEERING EFFORT

- Remove the steering wheel pad.  
(See page [SR-14](#))
- Start the engine and run it at idle.
- Measure the steering effort in both directions.

**Maximum steering effort:**

**6.9 N·m (70 kgf·cm, 61 in.-lbf)**

If steering effort is excessive, repair the power steering unit.  
HINT: Be sure to consider the tire type, pressure and contact surface before making your diagnosis.

- Tighten the steering wheel set nut.  
**Torque: 35 N·m (360 kgf·cm, 26 ft-lbf)**
- Install the steering wheel pad.  
(See page [SR-22](#))

# TILT STEERING COLUMN COMPONENTS

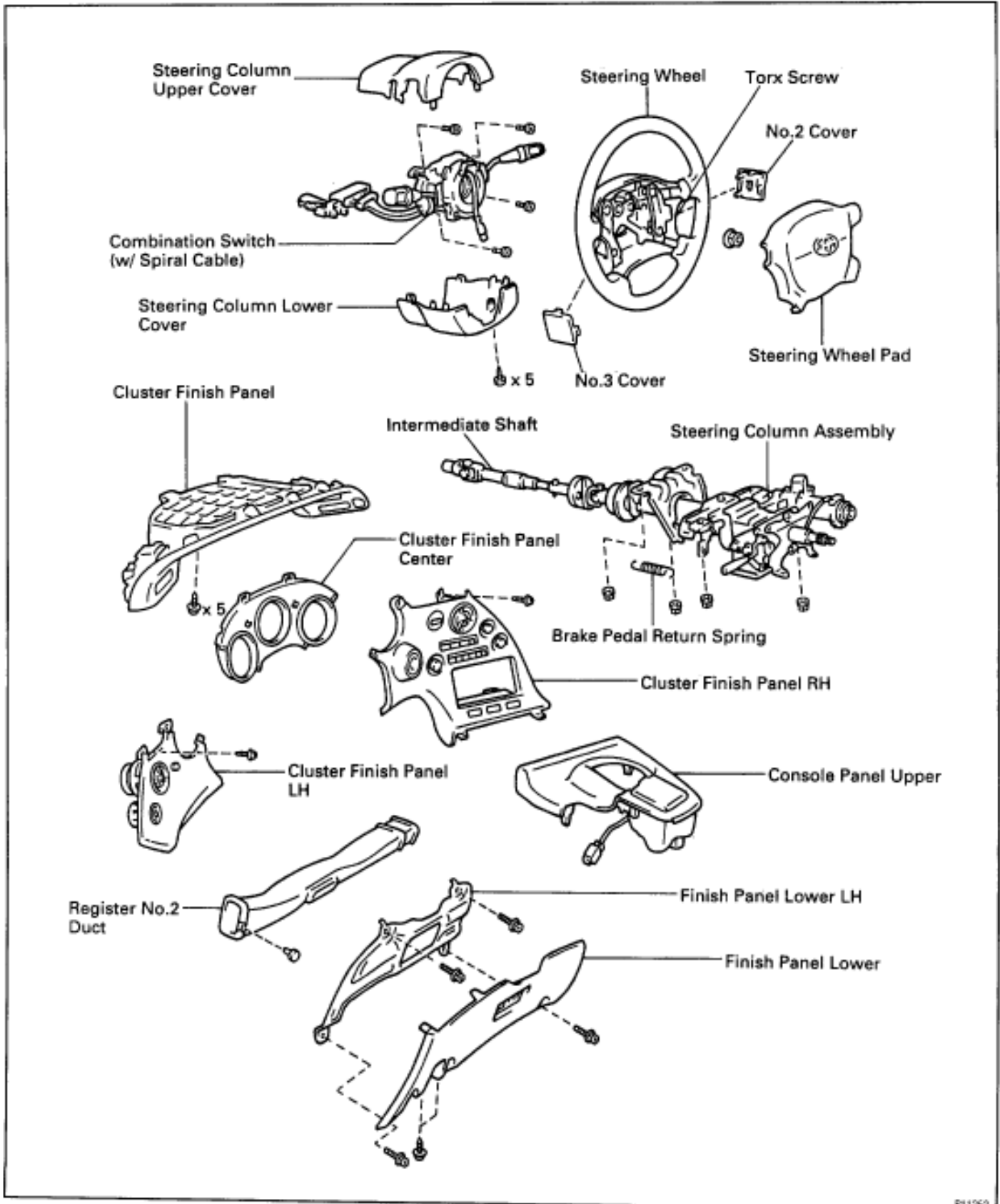

# COMPONENTS

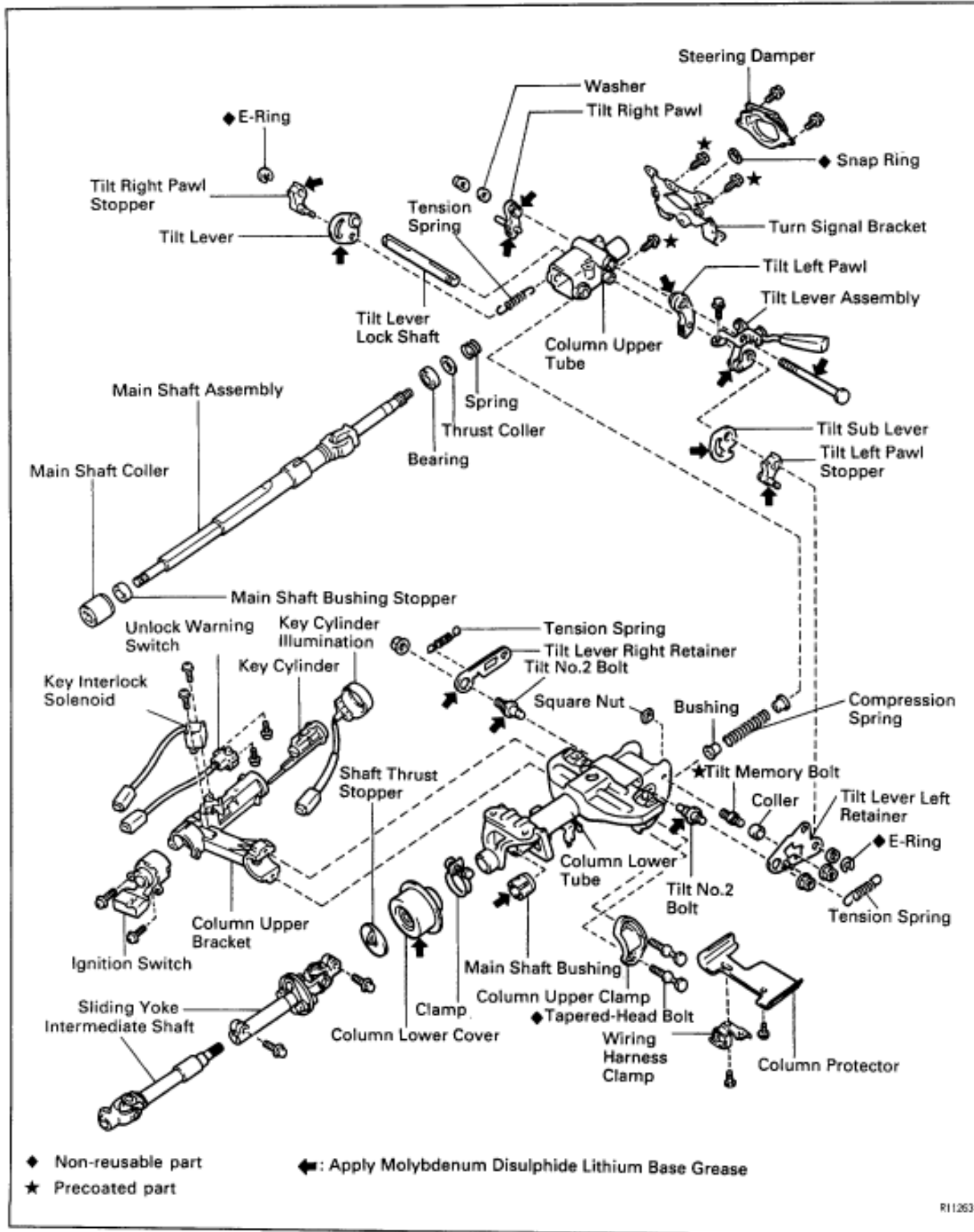

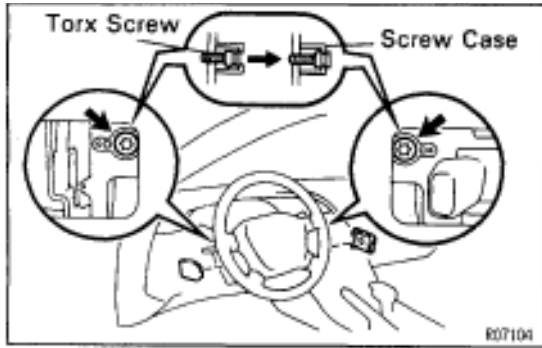

## STEERING COLUMN REMOVAL

### 1. REMOVE STEERING WHEEL PAD

- Place the front wheels facing straight ahead.
- Remove the No.2 and No.3 covers.

- Using a torx socket wrench, loosen the 3 torx screws.

**HINT:** Loosen the 3 screws until the groove along the screw circumference catches on the screw case.

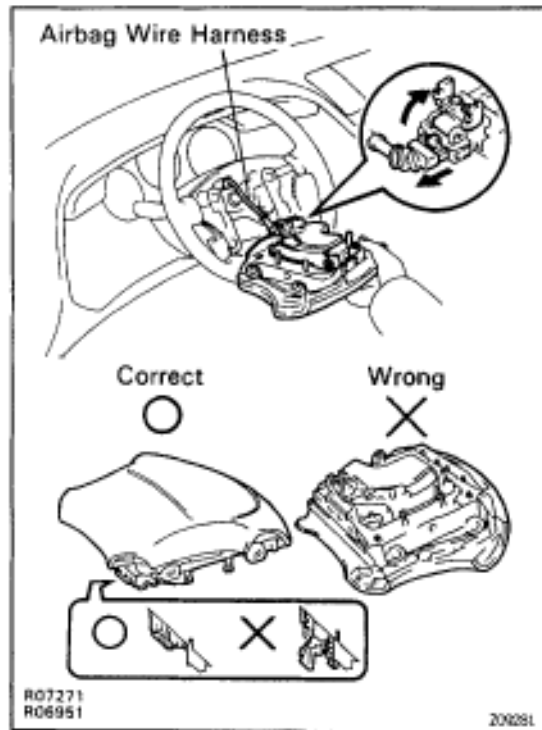

- Pull the pad out from the steering wheel and disconnect the airbag connector.

**NOTICE:** When removing the pad, take care not to pull the airbag wire harness.

#### CAUTION:

- When storing the pad, keep the upper surface of the pad facing upward.
- Never disassemble the pad.

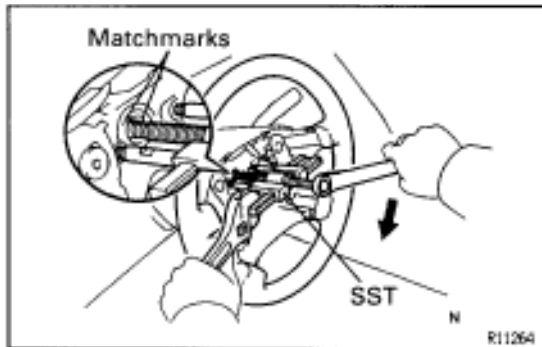

### 2. REMOVE STEERING WHEEL

- Disconnect the connector.
- Remove the wheel set nut.
- Place matchmarks on the wheel and main shaft.
- Using SST, remove the wheel.

SST 09950-50010 (09951-05010, 09952-05010, 09953-05020, 09954-05020)

### 3. REMOVE UPPER AND LOWER COLUMN COVERS

Remove 5 screws.

### 4. REMOVE THESE PARTS:

(See page [BO-45](#))

- Console panel upper
- Cluster finish panel
- Cluster finish panel RH
- Cluster finish panel LH
- Cluster finish panel center
- Finish panel lower
- Finish panel lower LH
- Register No.2 duct

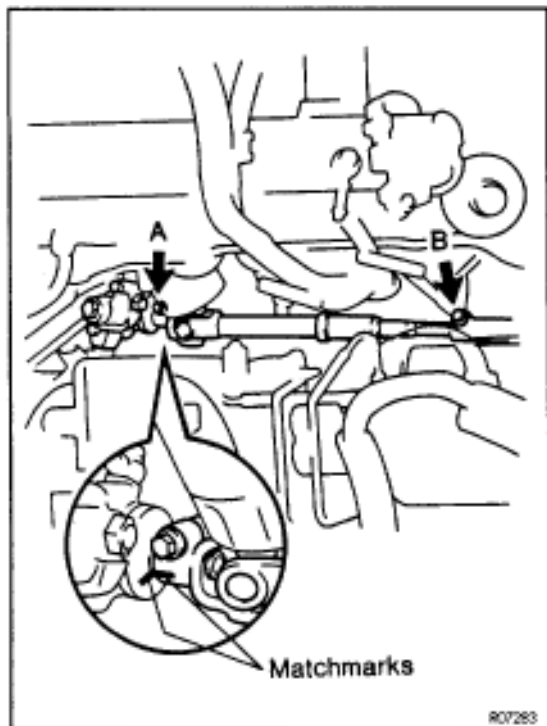
**5. REMOVE COMBINATION SWITCH**

- (a) Remove the 4 screws.
- (b) Disconnect the 4 connectors and airbag connector.

**6. DISCONNECT INTERMEDIATE SHAFT**

- (a) Place matchmarks on the intermediate shaft and control valve shaft.
- (b) Loosen the bolt B and remove the bolt A.

**7. REMOVE STEERING COLUMN ASSEMBLY**

- (a) Remove the brake pedal return spring.
- (b) Loosen the hole cover clamp.
- (c) Remove the 4 nuts.

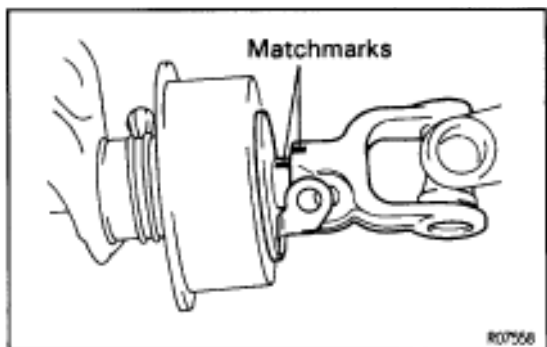
**STEERING COLUMN DISASSEMBLY**

**NOTICE:** When using a vise, do not overtighten it.

**1. REMOVE IGNITION KEY CYLINDER ILLUMINATION****2. REMOVE INTERMEDIATE SHAFT**

Remove the bolt.

**3. REMOVE SLIDING YOKE AND SHAFT THRUST STOPPER**

- (a) Remove the bolt.
- (b) Shift the stopper.
- (c) Place matchmarks on the yoke and main shaft.

**4. REMOVE COLUMN LOWER COVER**

Loosen the clamp.

**5. REMOVE COLUMN UPPER BRACKET**

- (a) Using a centering punch, mark the center of the 2 tapered-head bolts.
- (b) Using a 4–5 mm (0.16–0.20 in.) drill, drill into the 2 tapered-head bolts.
- (c) Using a screw extractor, remove the 2 tapered-head bolts.
- (d) Remove the bracket and column upper clamp.

**6. REMOVE WIRING HARNESS CLAMP AND COLUMN PROTECTOR****7. REMOVE COMPRESSION SPRING**

- (a) Using a torx socket wrench, remove the screw.
- (b) Remove the 2 bushings from the spring.

**8. REMOVE 3 TENSION SPRINGS****9. REMOVE TURN SIGNAL BRACKET**

Remove the 2 bolts.

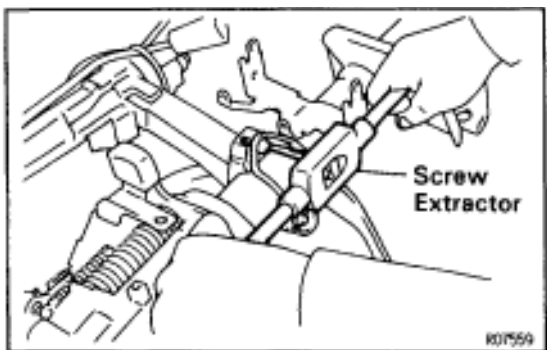

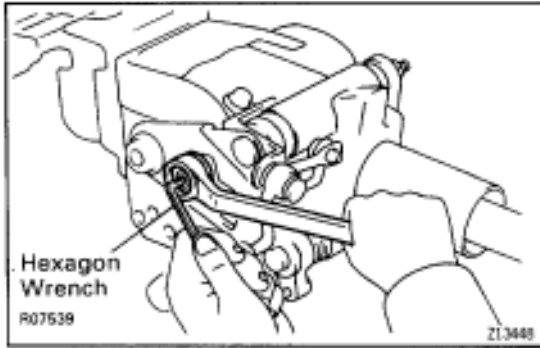
**10. REMOVE TILT LEVER RIGHT RETAINER**

Remove the nut and E-ring.

**11. REMOVE TILT LEVER LEFT RETAINER**

- (a) Using a hexagon wrench (4 mm) to hold the tilt memory bolt, remove the nut.
- (b) Remove the nut, washer and bolt.
- (c) Remove the nut, E-ring and spacer.
- (d) Remove the collar.

**12. REMOVE TILT RIGHT PAWL, TILT RIGHT PAWL STOPPER AND TILT LEVER****13. REMOVE TILT LEFT PAWL, TILT LEFT PAWL STOPPER, TILT SUB LEVER, TILT LEVER ASSEMBLY AND TILT LEVER LOCK SHAFT**

Remove the tilt lever set screw.

**14. REMOVE TILT MEMORY BOLT AND SQUARE NUT**

Using a hexagon wrench (4 mm), remove the bolt.

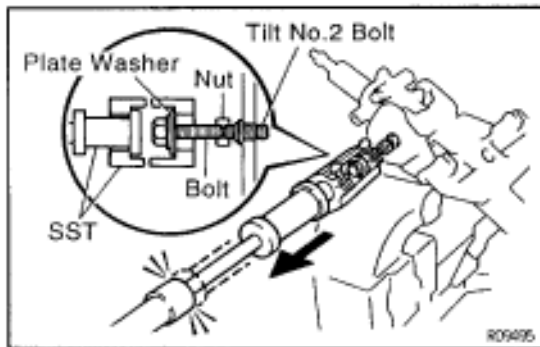
**15. REMOVE MAIN SHAFT ASSEMBLY WITH COLUMN UPPER TUBE**

- (a) Set SST, the nut (10 mm nominal diameter, 1.25 mm pitch), plate washer (36 mm outer diameter) and bolt (10 mm nominal diameter, 1.25 mm pitch, 50 mm length), as shown. SST 09910-00015 (09911-00011, 09912-00010)

Reference:

Nut 90170-10004

Plate washer 90201-10201

Bolt 91111-51050

- (b) Remove the 2 tilt No.2 bolts by using the sliding hammer on SST.
- (c) Remove the shaft assembly with the upper tube from the column lower tube.

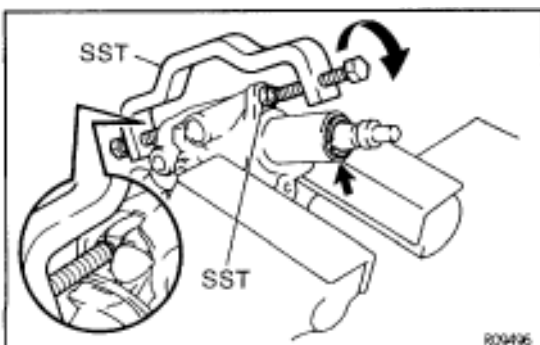
**16. REMOVE MAIN SHAFT ASSEMBLY**

- (a) Using SST, compress the compression spring. SST 09950-40010 (09957-04010, 09958-04010)
- (b) Using snap ring pliers, remove the snap ring.
- (c) Remove the main shaft assembly from the upper tube.
- (d) Remove the spring, bearing thrust collar and bearing from the main shaft.

**17. REMOVE MAIN SHAFT COLLAR AND MAIN SHAFT BUSHING STOPPER**



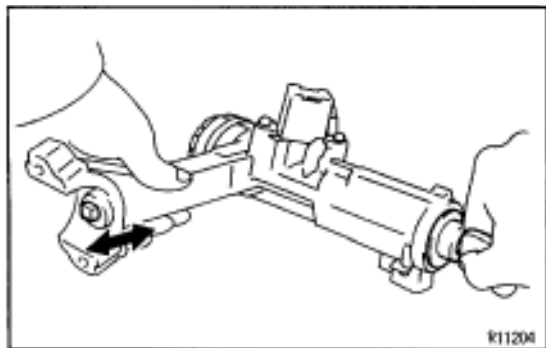

## STEERING COLUMN INSPECTION AND REPLACEMENT

### 1. INSPECT KEY CYLINDER

Check that the steering lock mechanism operates properly.

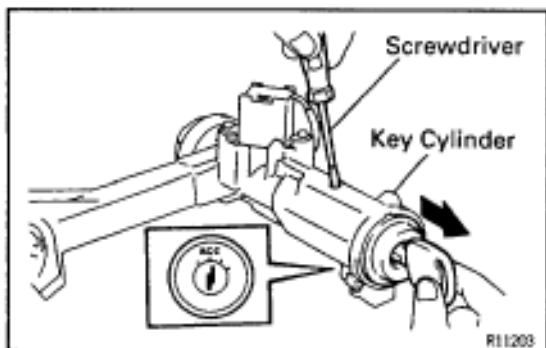

### 2. IF NECESSARY, REPLACE KEY CYLINDER

- Place the ignition key at the ACC position.
- Push down the stop pin with a screwdriver and pull out the key cylinder.
- Install a new cylinder.

HINT: Make sure the ignition key is at the ACC position.

### 3. IF NECESSARY, REPLACE UNLOCK WARNING SWITCH AND IGNITION SWITCH

- Remove the 2 screws and warning switch.
- Remove the 2 screws and ignition switch.
- Install a new ignition switch with the 2 screws.
- Install a new warning switch with the 2 screws.

### 4. A/T:

#### INSPECT KEY INTER LOCK SOLENOID

(See page [AT1-30](#))

### 5. A/T:

#### IF NECESSARY, REPLACE KEY INTERLOCK SOLENOID

- Remove the 2 screws and solenoid.
- Install a new solenoid with the 2 screws.

### 6. IF NECESSARY, REPLACE MAIN SHAFT BUSHING

- Using a screwdriver, depress the 3 projections on the busing to release the bushing, then remove the bushing.

**NOTICE: If the bushing interior is worn, install a new bushing.**

- Align the projections on a new bushing with the holes in the lower tube. Install the bushing until the projections are firmly engaged in the holes in the lower tube.

## STEERING COLUMN ASSEMBLY

**NOTICE: When using a vise, do not overtighten it.**

- APPLY MOLYBDENUM DISULPHIDE LITHIUM BASE GREASE (See page [SR-13](#))
- INSTALL MAIN SHAFT BUSHING STOPPER AND MAIN SHAFT COLLAR

**3. INSTALL MAIN SHAFT ASSEMBLY**

- (a) Install the bearing, bearing thrust collar and compression spring to the shaft assembly.
- (b) Install the shaft assembly into the column upper tube.  
**NOTICE: Do not bend the universal joint of the main shaft assembly more than 20°.**
- (c) Using SST, compress the compression spring.  
(See page [SR-16](#))
- (d) Using snap ring pliers, install a new snap ring.

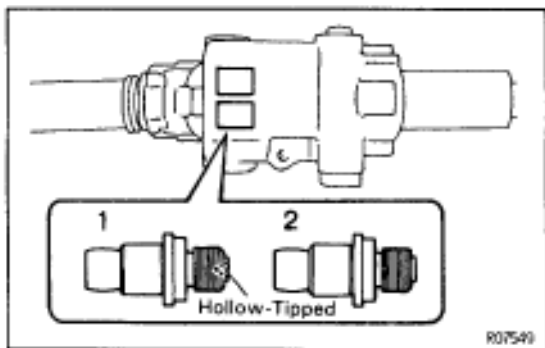
**4. SELECT TILT NO.2 BOLTS**

Select the bolt with the hollow-tipped thread end when the column upper tube mark is 1, and the bolt with the plain thread end when the mark is 2.

**NOTICE: Select the bolt type to match each number marked in the squares on the upper tube.**

**5. INSTALL MAIN SHAFT ASSEMBLY WITH COLUMN UPPER TUBE**

- (a) Install the shaft assembly with the upper tube into the lower tube.
- (b) Using a vise, press in the 2 tilt No.2 bolts.

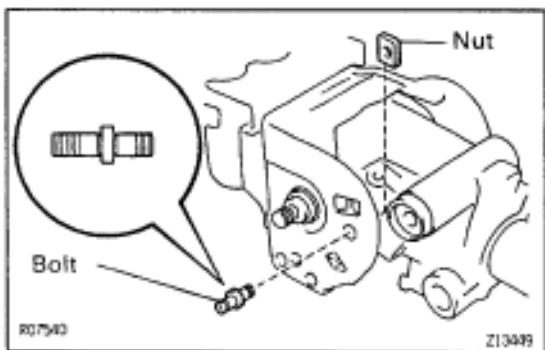
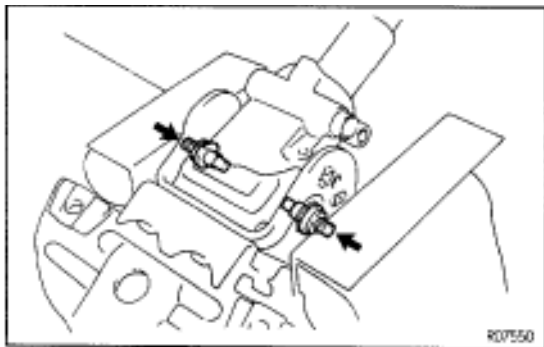
**6. INSTALL TILT MEMORY BOLT AND SQUARE NUT**

- (a) Apply sealant to 2 or 3 threads of the bolt.  
**Sealant:**  
**Part No. 08833-00080, THREE BOND 1344, LOCTITE 242 or equivalent.**
  - (b) Using a hexagon wrench (4 mm), install the shorter side of the bolt to the nut.  
**Torque: 6.4 N·m (65 kgf·cm, 56 in.·lbf)**
- 7. INSTALL TILT LEVER LOCK SHAFT, TILT LEVER ASSEMBLY, TILT SUB LEVER AND TILT LEVER**
- 8. INSTALL RIGHT AND LEFT TILT PAWLS**
- (a) Install the right and left pawls to the column upper tube and temporarily install the bolt and nut.  
**HINT: Install the pawl pin into the long hole of the tilt lever and tilt sub lever.**
  - (b) Torque the tilt lever assembly set screw.  
**Torque: 4.7 N·m (48 kgf·cm, 42 in.·lbf)**

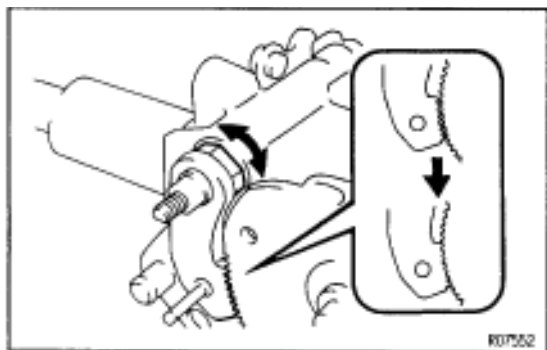

### 9. ENGAGE AND ADJUST RIGHT AND LEFT TILT PAWLS

- Engage the left pawl to the center of the ratchet.
- Using a spanner (17 mm), while turning the right pawl side collar, completely engage the right pawl to the ratchet.

#### NOTICE:

- Do not turn the collar after the right pawl is engaged.
- Keep the bolt and nut temporarily tightened.

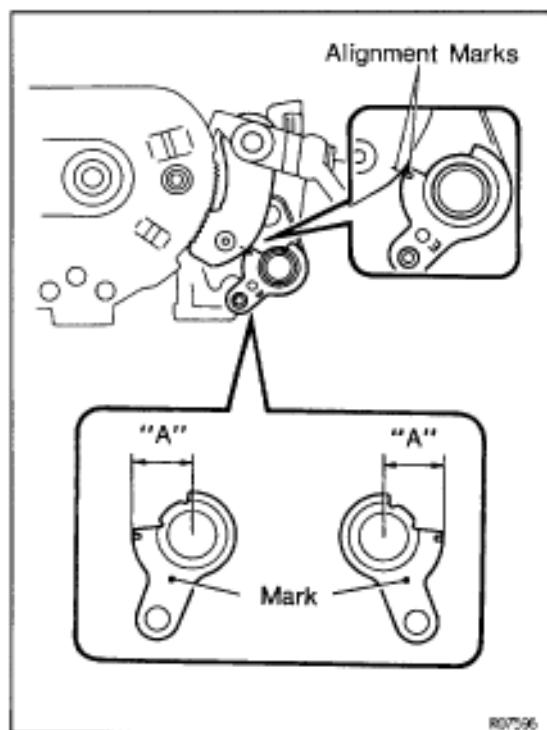

### 10. SELECT RIGHT AND LEFT TILT PAWL STOPPERS

- With the tilt pawl and ratchet engaged, install the pawl stoppers.
- Check that the alignment marks on the pawl stopper and pawl align when the pawl stopper is lightly rotated to the pawl side. If the alignment marks do not align, select the pawl stoppers according to the following table.

Right pawl stopper	Left pawl stopper	Dimension "A" mm (in.)
1	A	12.68–12.74 (0.4992–0.5016)
2	B	12.61–12.67 (0.4965–0.4988)
3	C	12.54–12.60 (0.4937–0.4961)
4	D	12.47–12.53 (0.4909–0.4933)
5	E	12.40–12.46 (0.4882–0.4906)
6	F	12.33–12.39 (0.4854–0.4878)
7	G	12.26–12.32 (0.4827–0.4850)

- After selecting the pawl stoppers, check that on both sides the pawl and ratchet are fully engaged.

### 11. INSTALL RIGHT AND LEFT TILT PAWL STOPPERS

### 12. INSTALL TILT LEVER LEFT RETAINER

- Remove the bolt and nut.

**NOTICE:** Take care to not turn the collar of the tilt left pawl.

- Install the collar to the tilt memory bolt.
- Install the retainer.
- Install the bolt, washer and torque the nut.

HINT: Install the bolt so that the groove in the bolt shaft faces upward.

**Torque: 5.9 N·m (60 kgf·cm, 52 in·lbf)**

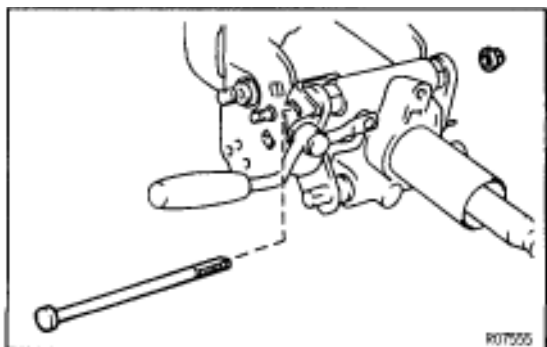

- (e) Torque the nut of the tilt No.2 bolt side.

**Torque: 15 N·m (150 kgf·cm, 11 ft·lbf)**

- (f) Torque the nut of the memory bolt side.

**Torque: 5.9 N·m (60 kgf·cm, 52 in·lbf)**

- (g) Install the spacer and a new E-ring.

### 13. INSTALL TILT LEVER RIGHT RETAINER

- (a) Torque the nut.

**Torque: 15 N·m (150 kgf·cm, 11 ft·lbf)**

- (b) Install a new E-ring.

### 14. INSTALL TURN SIGNAL BRACKET

- (a) Apply sealant to 2 or 3 threads of the 2 bolts.

**Sealant:**

**Part No. 08833-00080, THREE BOND 1344, LOCTITE 242 or equivalent.**

- (b) Torque the 2 bolts.

**Torque: 8.8 N·m (90 kgf·cm, 78 in·lbf)**

### 15. INSTALL 3 TENSION SPRINGS

### 16. INSTALL COMPRESSION SPRING

- (a) Install the 2 bushings to the spring.

- (b) Apply sealant to 2 or 3 threads of the torx screw.

**Sealant:**

**Part No. 08833-00080, THREE BOND 1344, LOCTITE 242 or equivalent.**

- (c) Using a torx socket wrench, torque the screw.

**Torque: 6.4 N·m (65 kgf·cm, 56 in·lbf)**

### 17. INSTALL COLUMN PROTECTOR AND WIRING HARNESS CLAMP

Tighten the 2 screws.

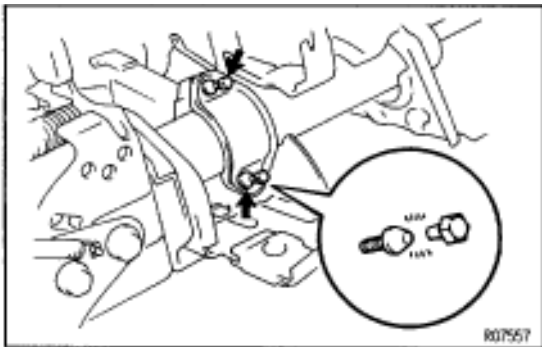

### 18. INSTALL COLUMN UPPER BRACKET

Tighten the 2 new tapered-head bolts until the bolt head breaks off.

### 19. INSTALL COLUMN LOWER COVER

Tighten the clamp.

### 20. INSTALL SHAFT THRUST STOPPER AND SLIDING YOKE

- (a) Align the matchmarks on the yoke and main shaft.

- (b) Torque the bolt.

**Torque: 35 N·m (360 kgf·cm, 26 ft·lbf)**

### 21. INSTALL INTERMEDIATE SHAFT

Temporarily tighten the bolt.

### 22. CHECK TILT OPERATION

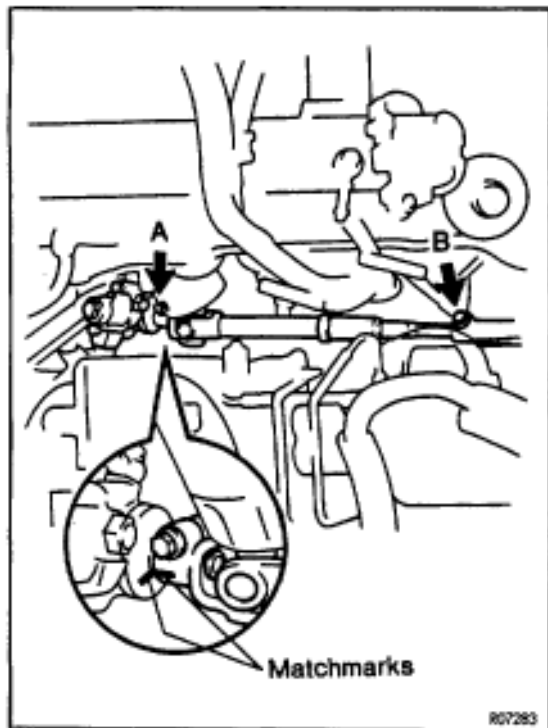

## STEERING COLUMN INSTALLATION

### 1. INSTALL STEERING COLUMN ASSEMBLY

- (a) Torque the 4 column assembly set nuts.  
**Torque: 25 N·m (260 kgf·cm, 19 ft·lbf)**
- (b) Install the brake pedal return spring.
- (c) Align the matchmarks on the intermediate shaft and control valve shaft.
- (d) Torque the bolt A.  
**Torque: 35 N·m (360 kgf·cm, 26 ft·lbf)**
- (e) Torque the bolt B.  
**Torque: 35 N·m (360 kgf·cm, 26 ft·lbf)**

### 2. INSTALL COMBINATION SWITCH

- (a) Tighten the 4 screws.
- (b) Connect the 4 connectors and airbag connector.

### 3. INSTALL THESE PARTS:

(See page [BO-45](#))

- (a) Register No.2 duct
- (b) Finish panel lower LH
- (c) Finish panel lower
- (d) Cluster finish panel center
- (e) Cluster finish panel LH
- (f) Cluster finish panel RH
- (g) Cluster finish panel
- (h) Console panel upper

### 4. INSTALL UPPER AND LOWER COLUMN COVER

Tighten the 5 screws.

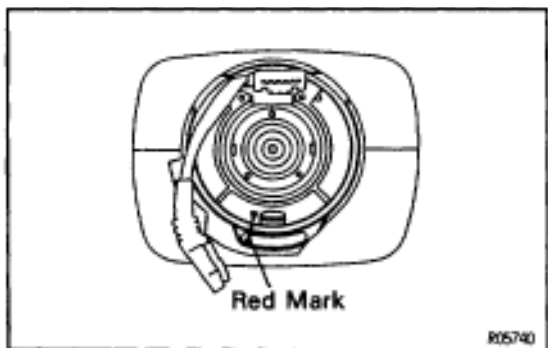

### 5. CENTER SPIRAL CABLE

- (a) Check that the front wheels are facing straight ahead.
- (b) Turn the spiral cable counterclockwise by hand until it becomes harder to turn the cable.
- (c) Then rotate the spiral cable clockwise about 3 turns to align the red mark.

HINT: The spiral cable will rotate about 3 turns to either left or right of the center.

### 6. INSTALL STEERING WHEEL

- (a) Align the matchmarks on the wheel and main shaft.
- (b) Torque the wheel set nut.  
**Torque: 35 N·m (360 kgf·cm, 26 ft·lbf)**
- (c) Connect the connector.

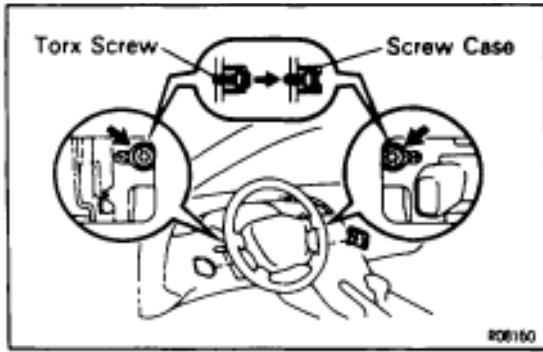

## 7. INSTALL STEERING WHEEL PAD

- (a) Connect the airbag connector.
- (b) Install the pad after confirming that the circumference groove of the torx screw is caught on the screw case.
- (c) Using a torx socket wrench, torque the 2 screws.

**Torque: 7.1 N·m (72 kgf·cm, 62 in·lbf)**

### NOTICE:

- Make sure the pad is installed to the specified torque.
- If the pad has been dropped, or there are cracks, dents or other defects in the case or connector, replace the pad with a new one.
- When installing the pad, take care that the wiring does not interfere with other parts and is not pinched between other parts.

## 8. CHECK STEERING WHEEL CENTER POINT

# POWER STEERING VANE PUMP COMPONENTS

## 2JZ-GE:

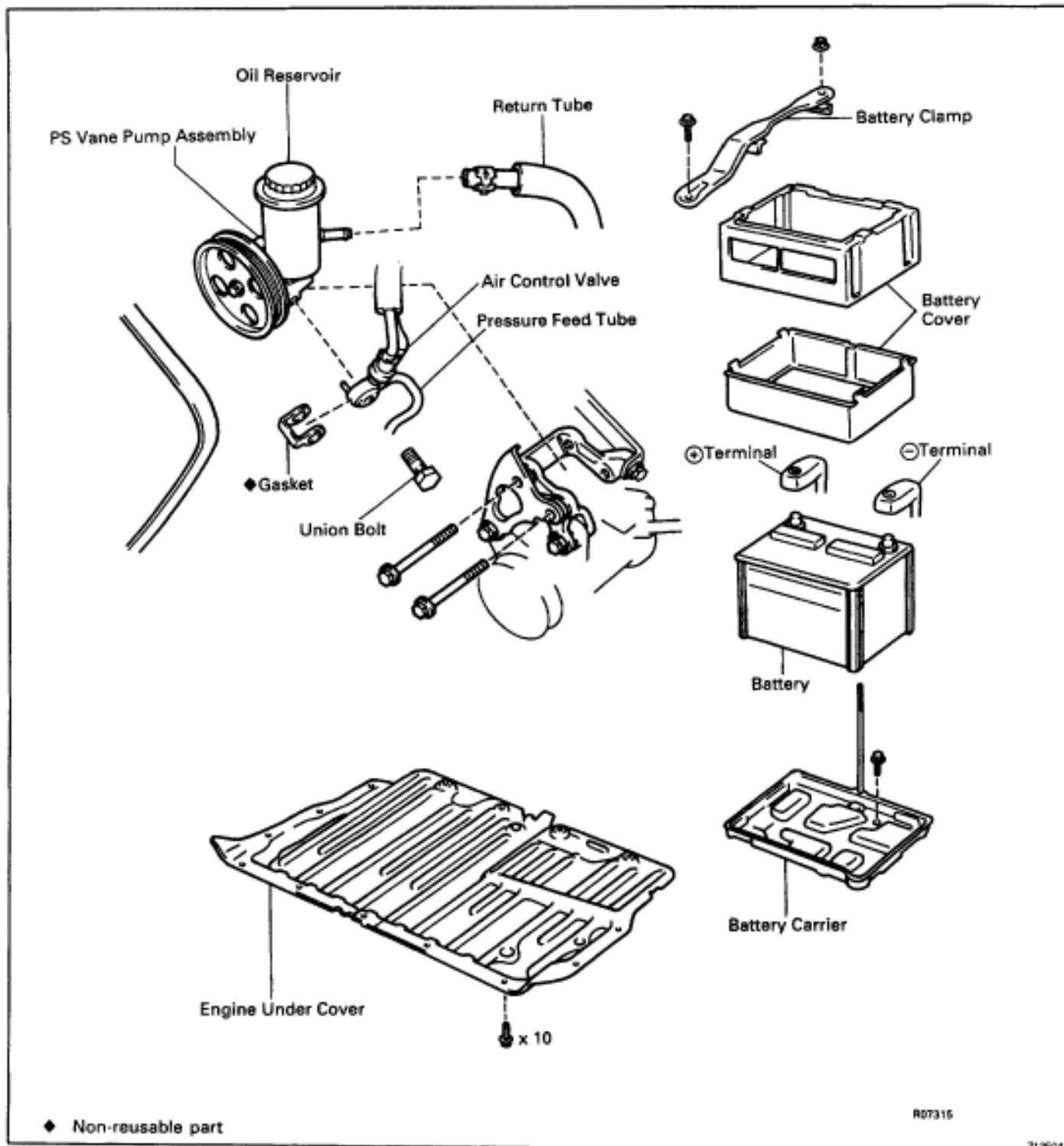

# COMPONENTS

## 2JZ-GTE:

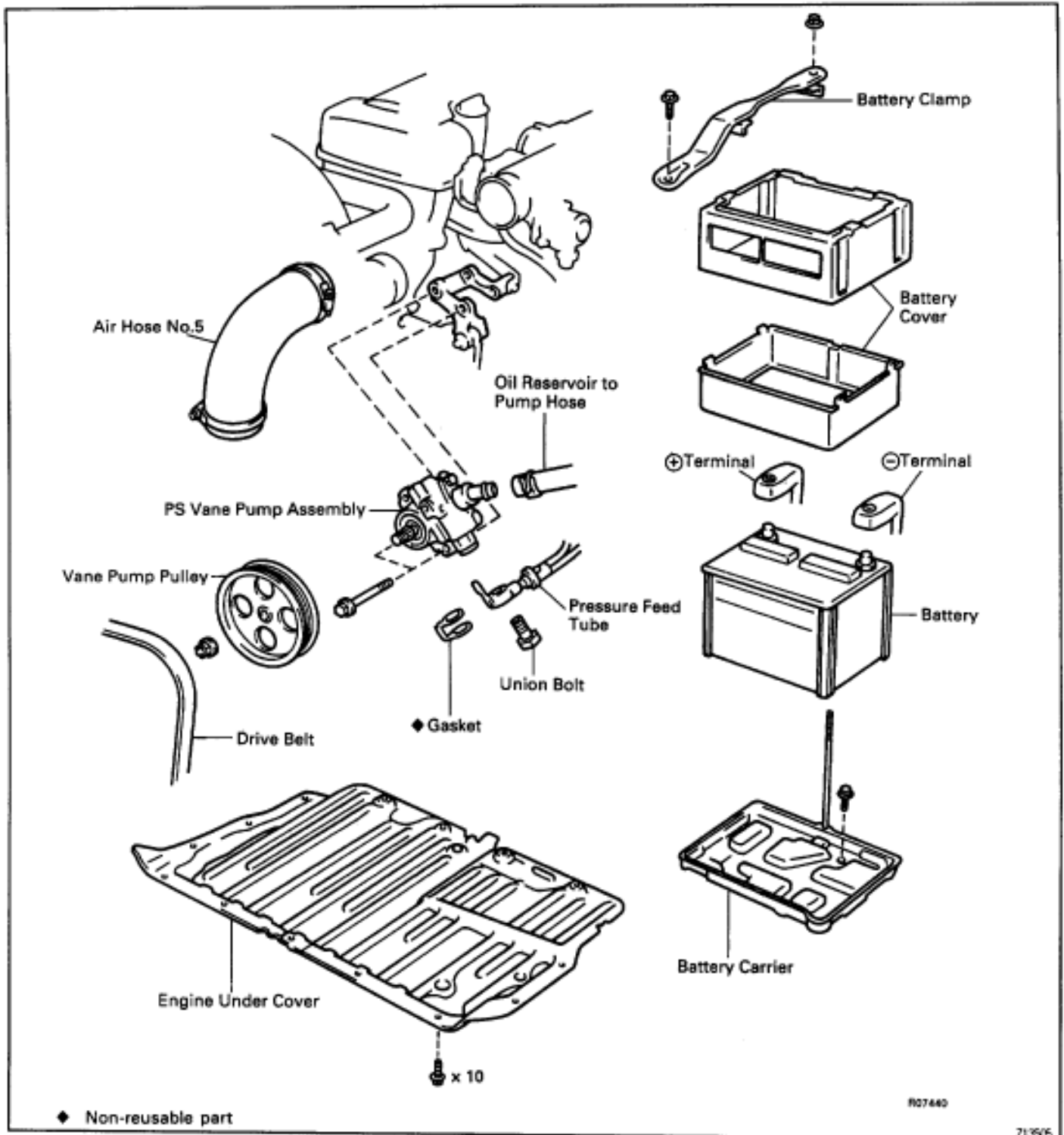



# COMPONENTS

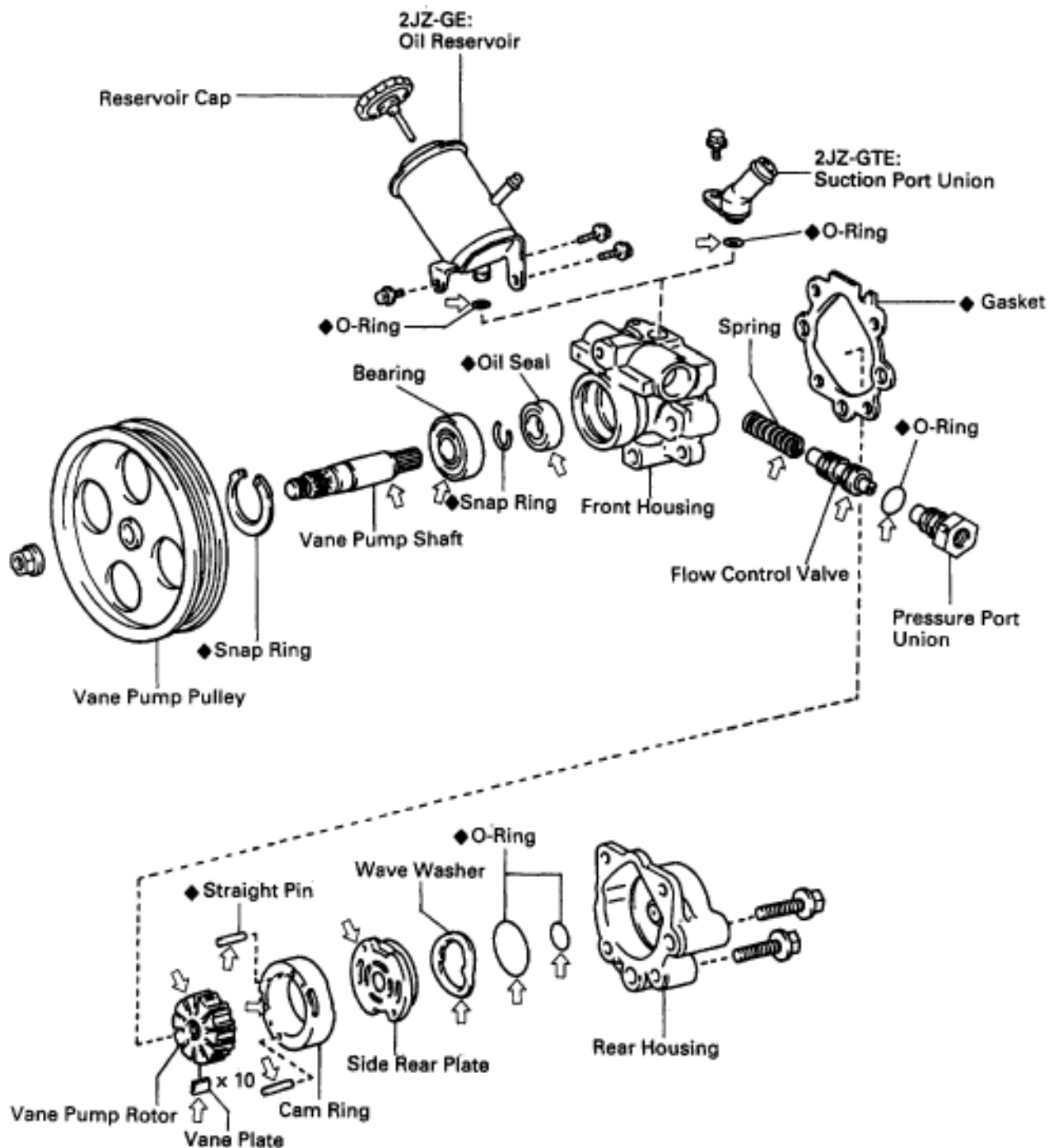

◆ Non-reusable part

↔ : Power steering fluid

## POWER STEERING VANE PUMP REMOVAL

### 1. REMOVE ENGINE UNDER COVER

Remove the 10 screws.

### 2. REMOVE BATTERY

### 3. 2JZ-GTE:

REMOVE AIR HOSE NO.5

### 4. 2JZ-GTE:

DISCONNECT OIL RESERVOIR TO PUMP HOSE

NOTICE: Take care not to spill fluid on the A/C compressor rotor.

### 5. 2JZ-GE:

DISCONNECT RETURN TUBE

NOTICE: Take care not to spill fluid on the A/C compressor rotor.

### 6. 2JZ-GTE:

REMOVE VANE PUMP PULLEY

Using SST to stop the pulley rotating, remove the nut.  
SST 09960-10010

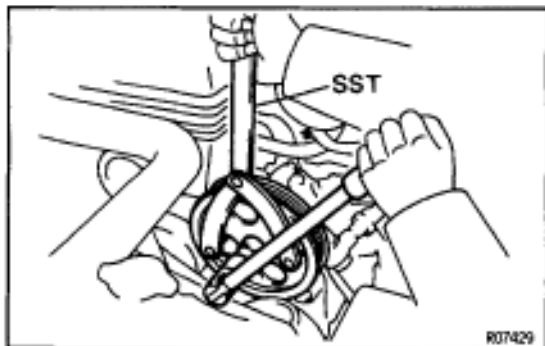

### 7. REMOVE PRESSURE FEED TUBE

Using a spanner (24 mm) to hold the pressure port union, remove the union bolt and gasket.

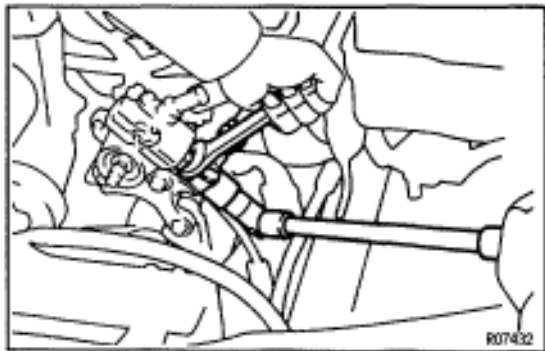

### 8. REMOVE PS VANE PUMP ASSEMBLY

Remove the 2 bolts.

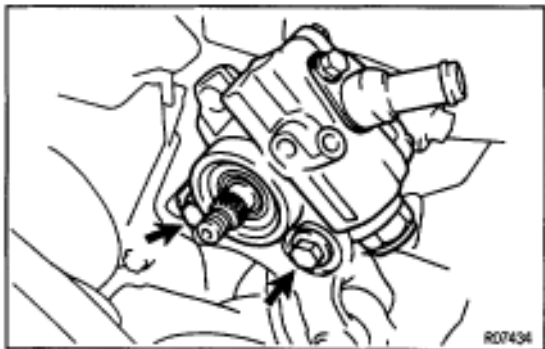

## POWER STEERING VANE PUMP DISASSEMBLY

NOTICE: When using a vise, do not overtighten it.

### 1. 2JZ-GE:

REMOVE VANE PUMP PULLEY

Using SST to stop the pulley rotating, remove the nut.  
SST 09960-10010

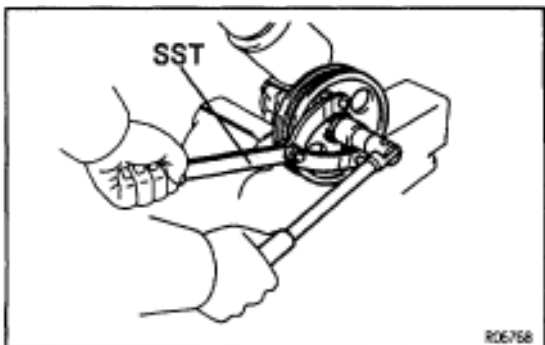

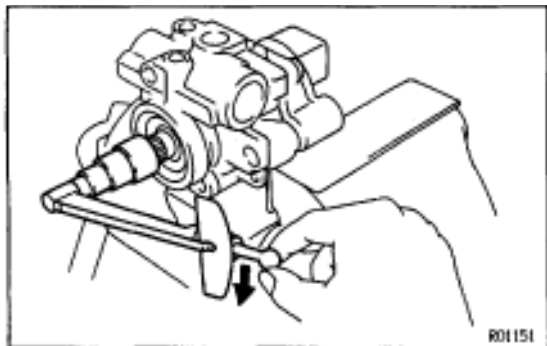

## 2. MEASURE PS VANE PUMP ROTATING TORQUE

- (a) Check that the shaft rotates smoothly without abnormal noise.
- (b) Temporarily install the pulley set nut, and using a torque wrench, check the pump rotating torque.

**Rotating torque: 0.2 N·m (2.5 kgf·cm, 2.2 in.·lbf) or less**

## 3. 2JZ-GE:

### REMOVE OIL RESERVOIR

- (a) Remove the 3 bolts.
- (b) Remove the O-ring from the reservoir.

## 4. 2JZ-GTE:

### REMOVE SUCTION PORT UNION

- (a) Remove the bolt.
- (b) Remove the O-ring from the union.

## 5. REMOVE PRESSURE PORT UNION, FLOW CONTROL VALVE AND SPRING

Remove the O-ring from the union.

## 6. REMOVE REAR HOUSING

Remove the 2 bolts.

## 7. REMOVE CAM RING, ROTOR AND 10 VANE PLATES

NOTICE: Take care to not drop the vane plates.

## 8. REMOVE 2 STRAIGHT PINS

## 9. REMOVE GASKET

## 10. REMOVE VANE PUMP SHAFT WITH BEARING

- (a) Using snap ring pliers, remove the snap ring from the front housing.

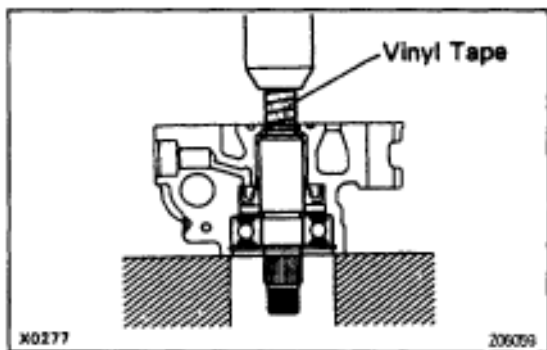

- (b) Wind vinyl tape on the serrated part of the shaft.
- (c) Using a press, press out the shaft with the bearing.

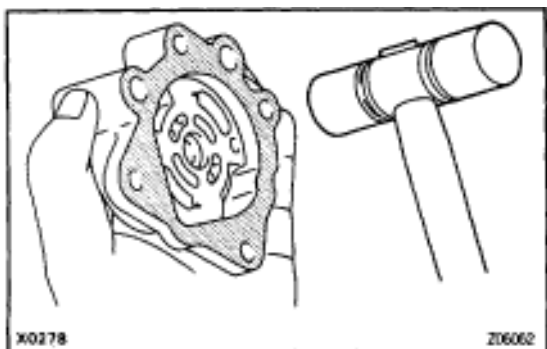

## 11. REMOVE SIDE REAR PLATE AND WAVE WASHER

- (a) Using a plastic hammer, tap the rear housing on the shaded area until the plate and washer come off.
- (b) Remove the 2 O-ring from the rear housing.

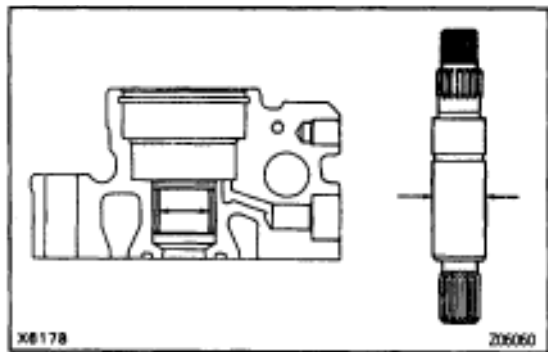

## POWER STEERING VANE PUMP INSPECTION AND REPLACEMENT

**NOTICE:** When using a vise, do not overtighten it.

### 1. MEASURE OIL CLEARANCE BETWEEN VANE PUMP SHAFT AND BUSHING

Using a micrometer and caliper gauge, measure the oil clearance.

	Oil clearance	mm (in.)
Standard	0.03–0.05	(0.0012–0.0020)
Maximum	0.07	(0.0028)

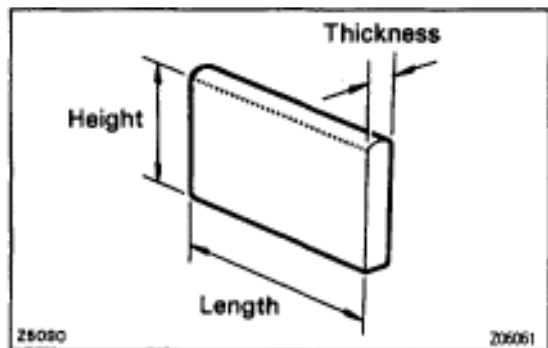

### 2. INSPECT VANE PUMP ROTOR AND VANE PLATES

(a) Using a micrometer, measure the height, thickness and length of the 10 vane plates.

	Minimum	mm (in.)
Height	8.6	(0.339)
Thickness	1.40	(0.0551)
Length	14.99	(0.5902)

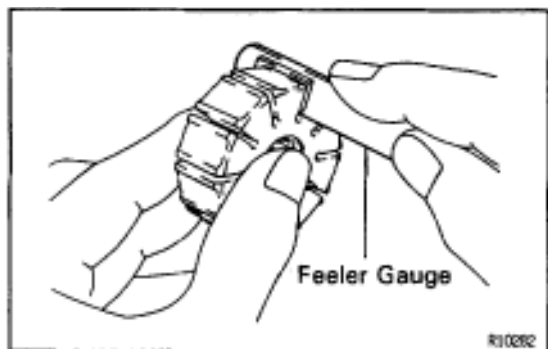

(b) Using a feeler gauge, measure the clearance between the rotor groove and plate.

	Clearance	mm (in.)
Maximum	0.035	(0.0014)

If more than maximum, replace the plate and/or rotor with one having the same mark stamped on the cam ring.

**Inscribed mark:**

**1, 2, 3, 4 or None**

**HINT:** There are 5 vane lengths with the following rotor and cam ring marks:

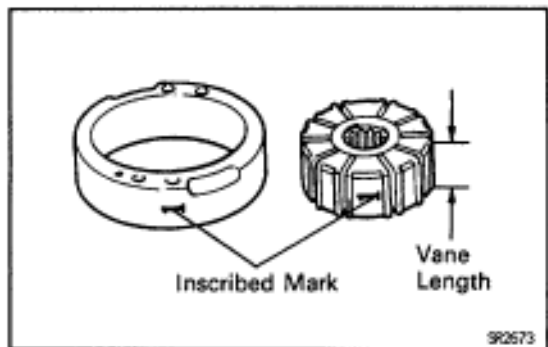

Rotor and cam ring number	Vane plate length mm (in.)
None	14.999–15.001 (0.59051–0.59059)
1	14.997–14.999 (0.59043–0.59051)
2	14.995–14.997 (0.59035–0.59043)
3	14.993–14.995 (0.59027–0.59035)
4	14.991–14.993 (0.59020–0.59027)

### 3. INSPECT FLOW CONTROL VALVE

(a) Coat the valve with power steering fluid and check that it falls smoothly into the valve hole by its own weight.

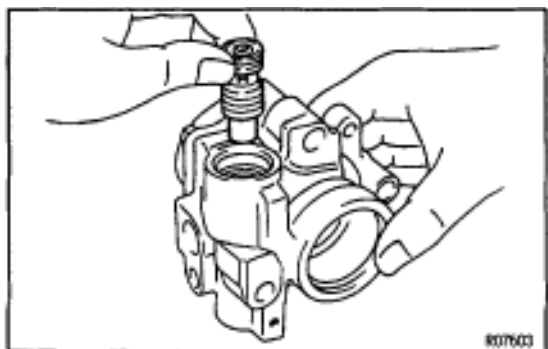

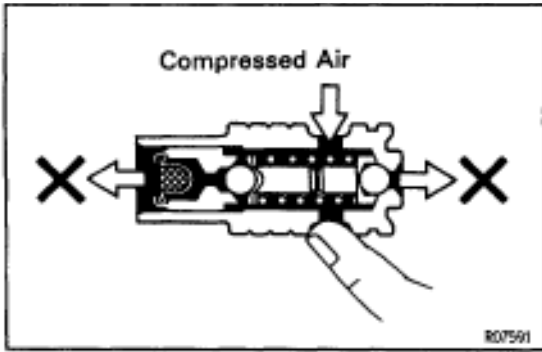

- (b) Check the valve for leakage. Close one of the holes and apply 392–490 kPa (4–5 kgf/cm<sup>2</sup>, 57–71 psi) of compressed air into the opposite side, and confirm that air does not come out from the end holes.

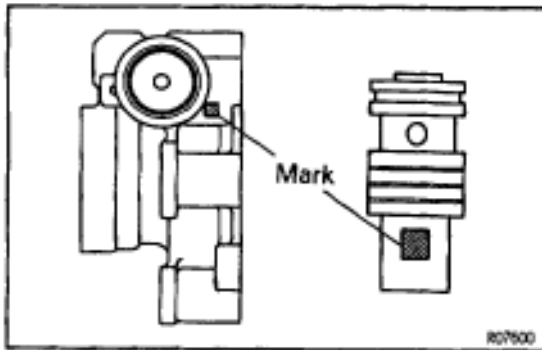

If necessary, replace the valve with one having the same letter as inscribed on the front housing.

Inscribed mark:

A, B, C, D, E or F

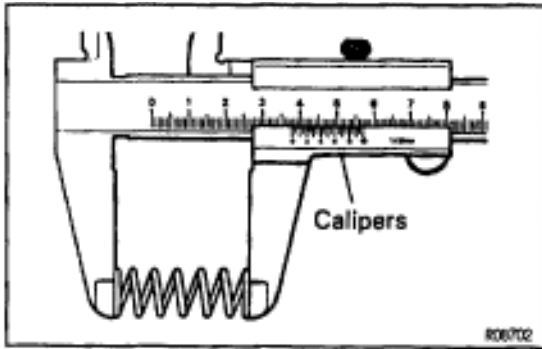

**4. INSPECT SPRING**

Using calipers, measure the free length of the spring.

	Free length	mm (in.)
Minimum	33	(1.30)

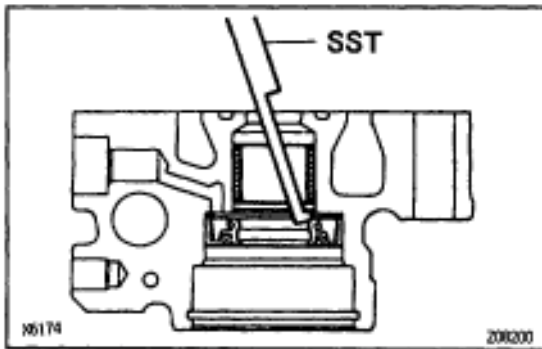

**5. IF NECESSARY, REPLACE OIL SEAL**

- (a) Using SST, tap out the oil seal.  
SST 09631–10030

**NOTICE:** Be careful not to damage the bushing of the front housing.

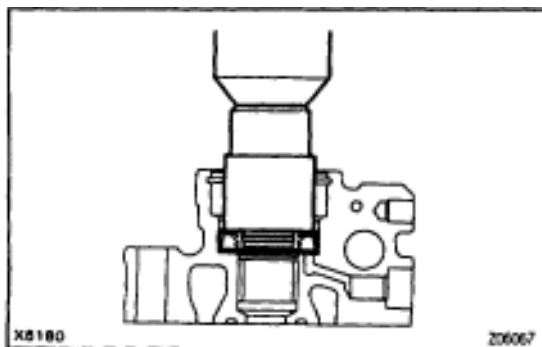

- (b) Coat a new oil seal lip with power steering fluid.  
(c) Using a socket wrench (24 mm), press in the oil seal.  
**NOTICE:** Make sure you install the oil seal facing the correct direction.

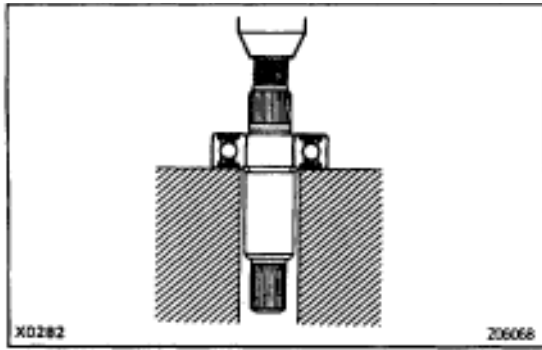

## 6. IF NECESSARY, REPLACE BEARING

- (a) Using a press, press out the bearing.
- (b) Using snap ring pliers, remove the snap ring from the vane pump shaft.
- (c) Using snap ring pliers, install a new snap ring.

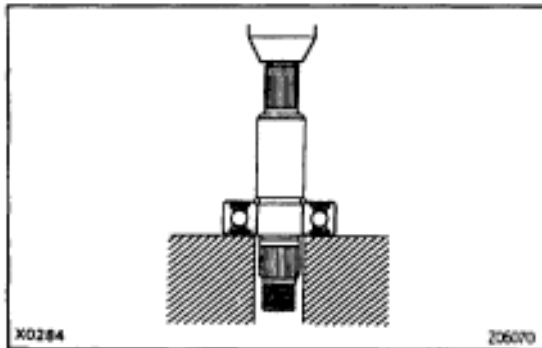

- (d) Using a press, press in a new bearing.

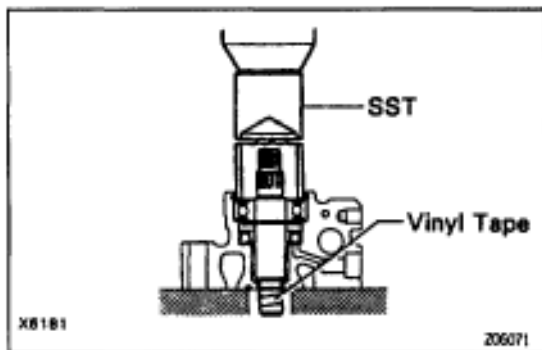

## POWER STEERING VANE PUMP ASSEMBLY

**NOTICE:** When using a vise, do not overtighten it.

1. **COAT WITH POWER STEERING FLUID**  
(See page [SR-25](#))
2. **INSTALL VANE PUMP SHAFT WITH BEARING**
  - (a) Wind vinyl tape on the serrated part of the shaft.
  - (b) Using SST, press in the shaft with the bearing to the front housing.

SST 09608-30012 (09608-04030)

**NOTICE:** Be careful not to damage the oil seal.

- (c) Using snap ring pliers, install a new snap ring to the front housing.

## 3. INSTALL STRAIGHT PINS

Using a plastic hammer, drive in 2 new straight pins to the front housing.

## 4. INSTALL CAM RING

Align the holes of the ring and straight pins, and install the ring with the inscribed mark facing outward.

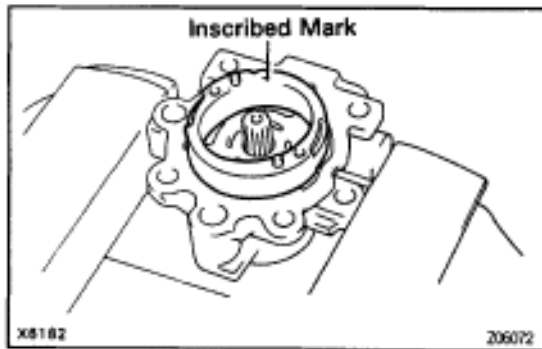

## 5. INSTALL VANE PUMP ROTOR

Install the rotor with the inscribed mark facing outward.

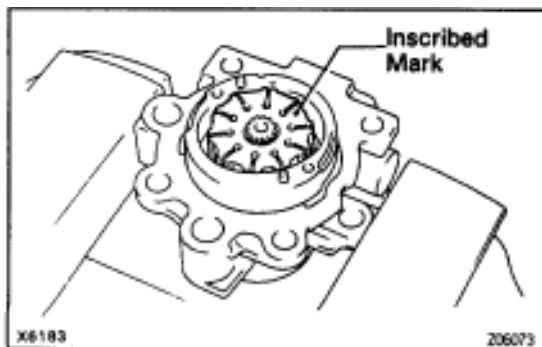

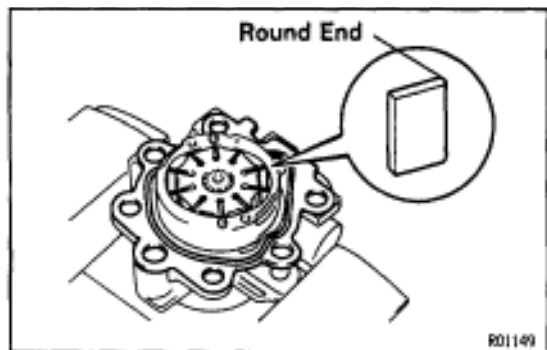
**6. INSTALL 10 VANE PLATES**

Install the plate with the round end facing outward.

**7. INSTALL GASKET**

Install a new gasket to the front housing.

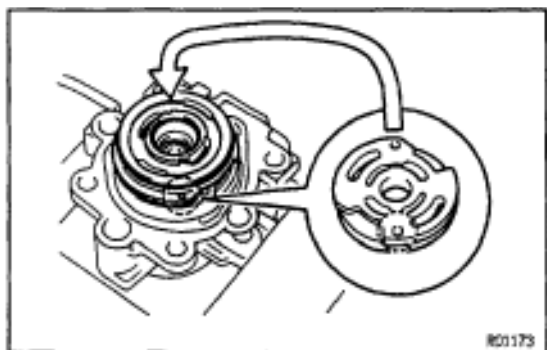
**8. INSTALL SIDE REAR PLATE**

Align the holes of the plate and straight pins.

**NOTICE:** Make sure you install the plate facing the correct direction.

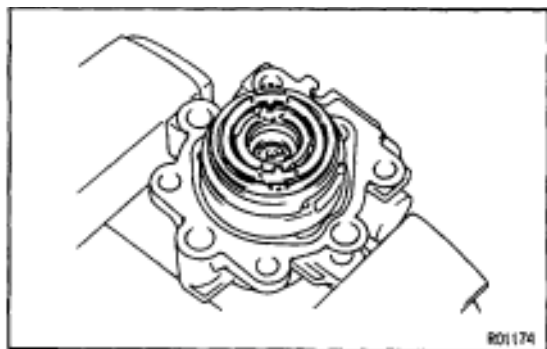
**9. INSTALL WAVE WASHER**

Install the washer so that its protrusions fit into the slots in the side rear plate.

**10. INSTALL REAR HOUSING**

- Coat 2 new O-rings with power steering fluid.
- Install the 2 O-ring to the housing.
- Torque the 2 bolts.

**Torque: 17 N·m (170 kgf·cm, 12 ft·lbf)**

**11. INSTALL SPRING, FLOW CONTROL VALVE AND PRESSURE PORT UNION**

- Coat a new O-ring with power steering fluid and install it to the union.
- Torque the union.

**Torque: 83 N·m (850 kgf·cm, 61 ft·lbf)**

**12. 2JZ-GTE:****INSTALL SUCTION PORT UNION**

- Install a new O-ring to the union.
- Torque the bolt.

**Torque: 13 N·m (130 kgf·cm, 9 ft·lbf)**

**13. 2JZ-GE:****INSTALL OIL RESERVOIR**

- Coat a new O-ring with power steering fluid and install it to the reservoir.
- Torque the 3 bolts.

**Torque:**

**Front side bolt: 13 N·m (130 kgf·cm, 9 ft·lbf)**

**Rear side bolts: 17 N·m (170 kgf·cm, 12 ft·lbf)**

**14. MEASURE PS VANE PUMP ROTATING TORQUE**  
(See page [SR-27](#))

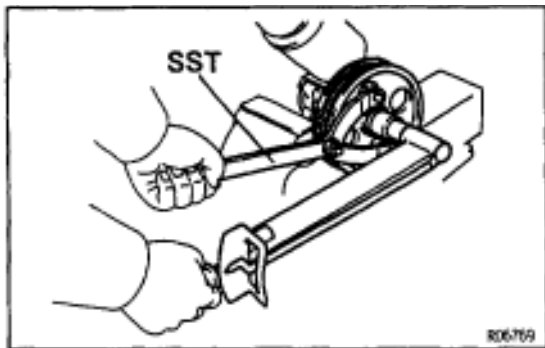
**15. 2JZ-GE:****INSTALL VANE PUMP PULLEY**

Using SST to stop the pulley rotating, torque the nut.

SST 09960-10010

Torque: 43 N·m (440 kgf·cm, 32 ft·lbf)

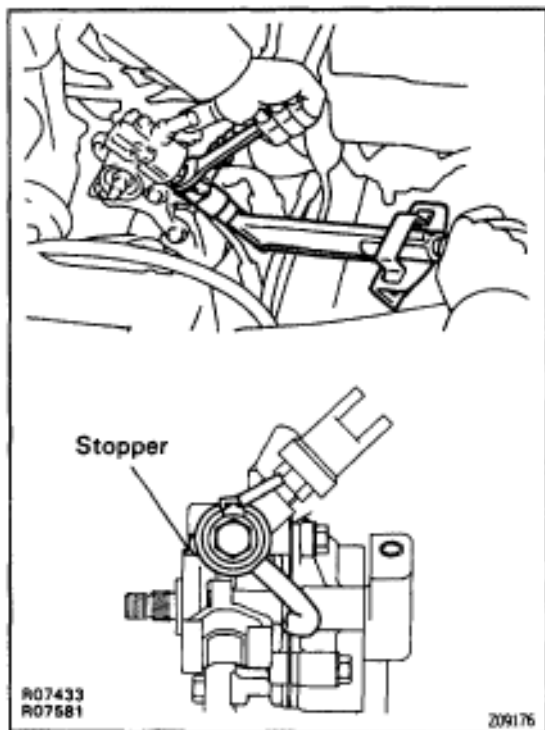
**POWER STEERING VANE PUMP INSTALLATION****1. INSTALL VANE PUMP ASSEMBLY**

Torque the 2 bolts.

Torque: 58 N·m (590 kgf·cm, 42 ft·lbf)

**2. CONNECT PRESSURE FEED TUBE**

Using a spanner (24 mm) to hold the pressure port union, torque the union bolt with a new gasket.

HINT: Make sure the stopper is touching the pump housing as shown, then torque the union bolt.

Torque: 49 N·m (500 kgf·cm, 36 ft·lbf)

**3. 2JZ-GTE:****INSTALL VANE PUMP PULLEY**

Using SST to stop the pulley rotating, torque the nut.

SST 09960-10010

Torque: 43 N·m (440 kgf·cm, 32 ft·lbf)

**4. 2JZ-GE:****CONNECT RETURN TUBE****5. 2JZ-GTE:****CONNECT OIL RESERVOIR TO PUMP HOSE****6. 2JZ-GTE:****INSTALL AIR HOSE NO.5****7. INSTALL BATTERY****8. INSTALL ENGINE UNDER COVER**

Install the 10 screws.



# POWER STEERING GEAR COMPONENTS

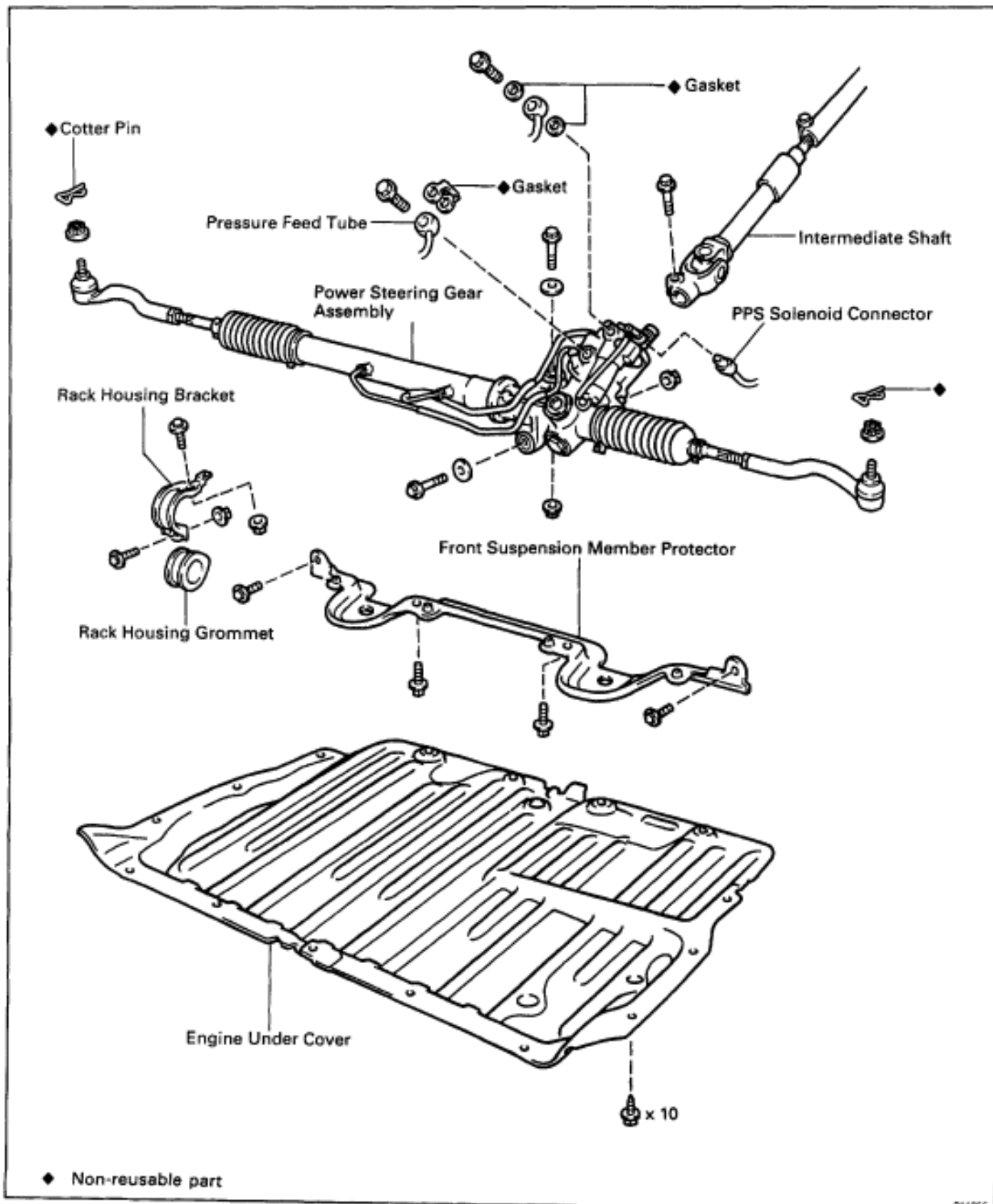

# COMPONENTS

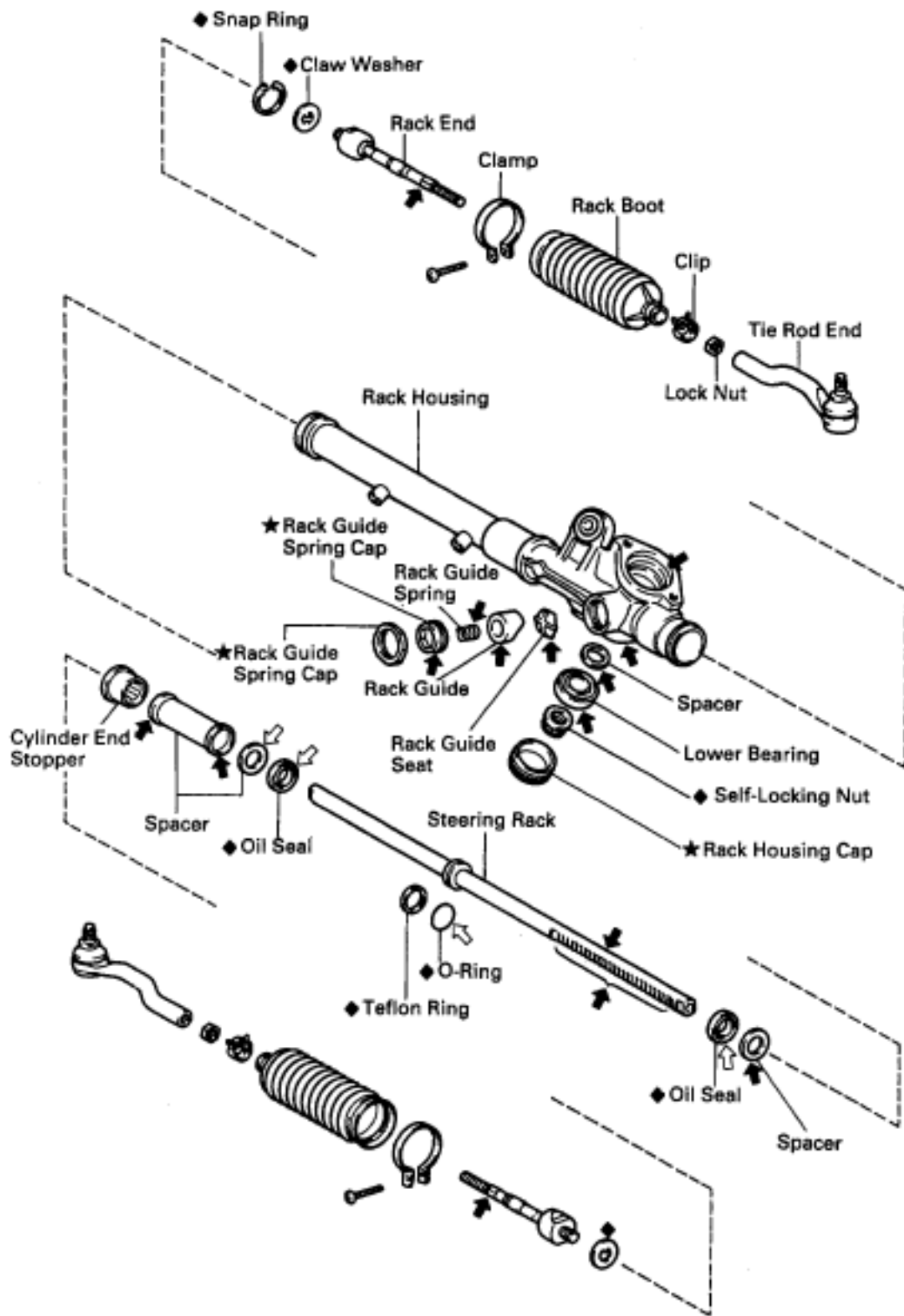

◆ Non-reusable part

★ Precoated part

↙ : Apply Molybdenum Disulphide Lithium Base Grease

↘ : Apply Power Steering Fluid

R07454

# COMPONENTS

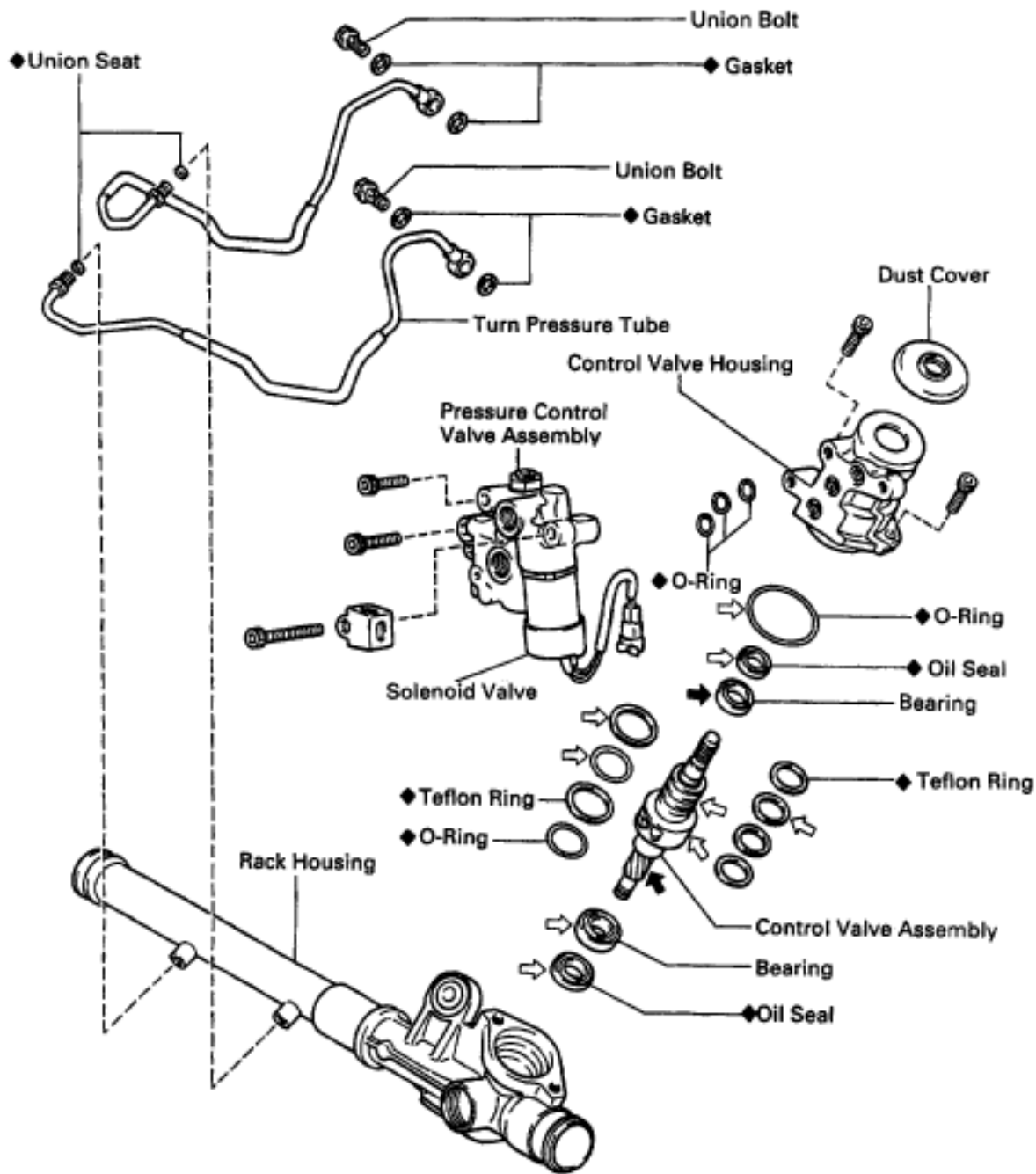

◆ Non-reusable part

◀ : Apply Molybdenum Disulphide Lithium Base Grease  
 ⇐ : Apply Power Steering Fluid

## POWER STEERING GEAR REMOVAL

1. **REMOVE ENGINE UNDER COVER**  
Remove the 10 screws.
2. **REMOVE FR SUSPENSION MEMBER PROTECTOR**  
Remove the 4 bolts.
3. **DISCONNECT INTERMEDIATE SHAFT**  
(See page [SR-15](#))
4. **DISCONNECT RH AND LH TIE ROD ENDS**  
(See page [SA-17](#))
5. **DISCONNECT PRESSURE FEED TUBE**  
Remove the union bolt and gasket.
6. **DISCONNECT RETURN TUBE**  
Remove the union bolt and 2 gaskets.
7. **DISCONNECT PPS SOLENOID CONNECTOR**
8. **REMOVE RACK HOUSING BRACKET AND GROMMET**  
Remove the 2 bolts and nuts.
9. **REMOVE POWER STEERING GEAR ASSEMBLY**  
Remove the 2 bolts and nuts.

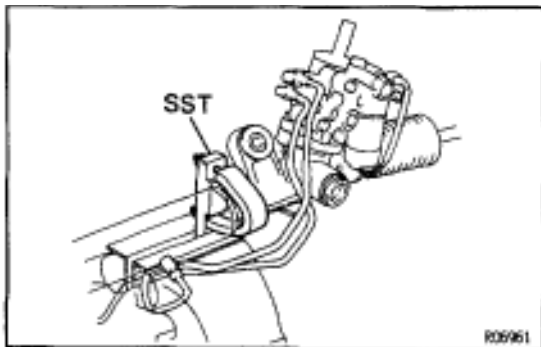

## POWER STEERING GEAR DISASSEMBLY

**NOTICE:** When using a vise, do not overtighten it.

1. **SECURE PS GEAR ASSEMBLY IN VISE**  
Using SST, secure the gear assembly in a vise.  
SST 09612-00012
2. **REMOVE TURN PRESSURE TUBES**
  - (a) Remove the 2 union bolts and 4 gaskets.
  - (b) Using SST, remove the 2 tubes.  
SST 09633-00020
  - (c) Remove the 2 union seats.
3. **REMOVE RH AND LH TIE ROD ENDS AND LOCK NUTS**  
Place matchmarks on the tie rod end and rack end and loosen the lock nut.
4. **REMOVE RH AND LH CLIPS, RACK BOOTS AND CLAMPS**  
**NOTICE:**
  - Be careful not to damage the boot.
  - Mark the RH and LH boots.

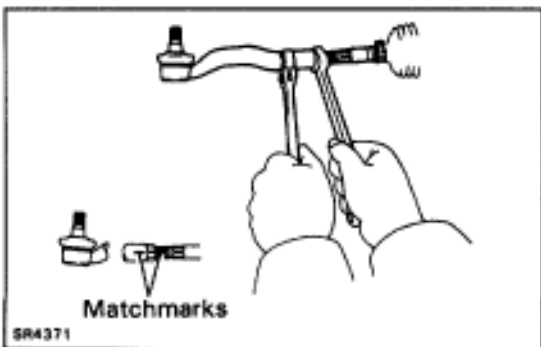
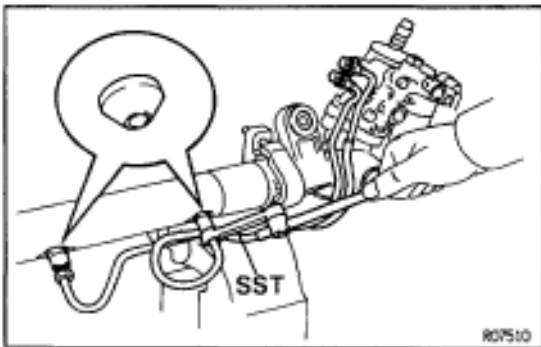

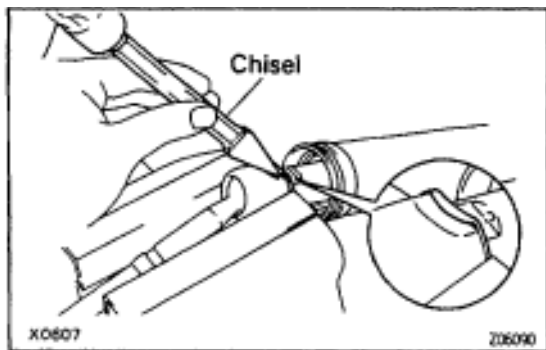

## 5. REMOVE RH AND LH RACK ENDS AND CLAW WASHERS

- (a) Using a chisel and hammer, unseat the washer.

**NOTICE:** Avoid any impact to the steering rack.

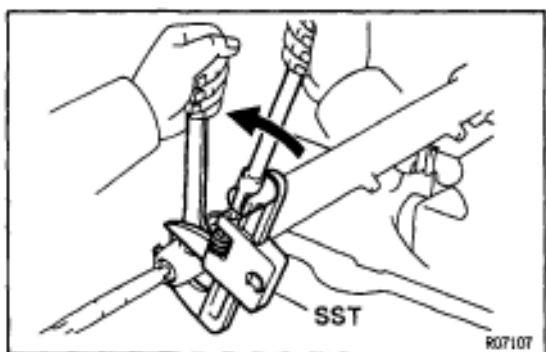

- (b) Using a spanner (22 mm) to hold the steering rack, and using SST, remove the rack end.

SST 09922-10010

**NOTICE:** Use SST 09922-10010 in the direction shown in the illustration.

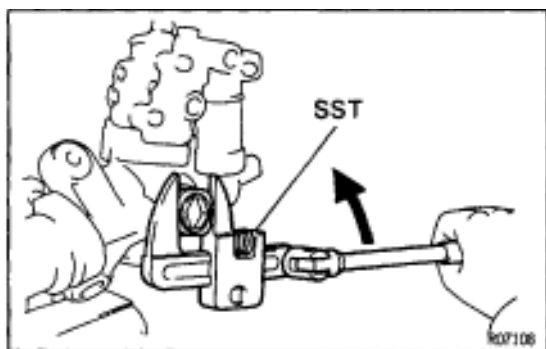

## 6. REMOVE RACK GUIDE SPRING CAP LOCK NUT

Using SST, remove the nut.

SST 09922-10010

**NOTICE:** Use SST 09922-10010 in the direction shown in the illustration.

## 7. REMOVE RACK GUIDE SPRING CAP, RACK GUIDE SPRING, RACK GUIDE AND RACK GUIDE SEAT

- (a) Using a hexagon wrench (24 mm), remove the cap.  
 (b) Remove the seat from the guide.

## 8. REMOVE RACK HOUSING CAP

## 9. REMOVE SELF-LOCKING NUT, BEARING AND SPACER

Using SST to stop the control valve shaft rotating, remove the nut.

SST 09616-00010

## 10. REMOVE DUST COVER

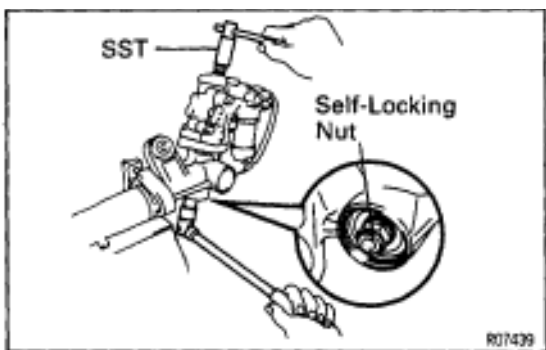

## 11. REMOVE CONTROL VALVE HOUSING

- (a) To prevent oil seal lip damage, wind vinyl tape on the serrated part of the control valve shaft.  
 (b) Using a hexagon wrench (6 mm), remove the 2 bolts.  
 (c) Remove the O-ring from the housing.

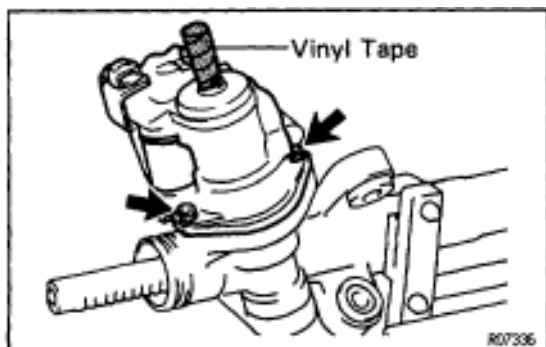

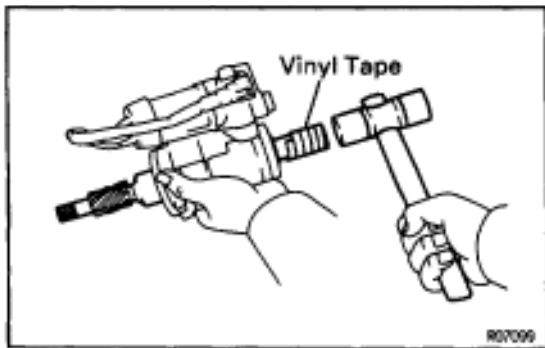
**12. REMOVE CONTROL VALVE ASSEMBLY**

Using a plastic hammer, tap out the control valve.

**13. REMOVE CYLINDER END STOPPER AND 2 SPACERS**

Using snap ring pliers, remove the snap ring from the rack housing.

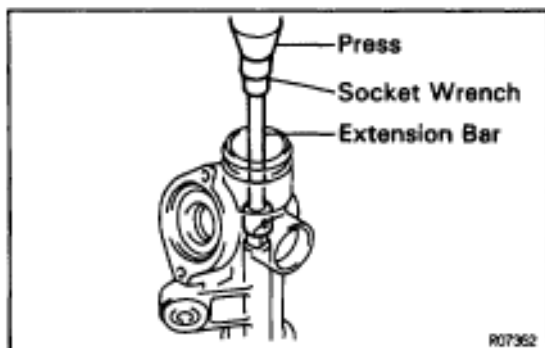
**14. REMOVE STEERING RACK AND OIL SEAL**

Using an extension bar or brass bar and a press, press out the rack.

**NOTICE:** Take care to not drop the rack.

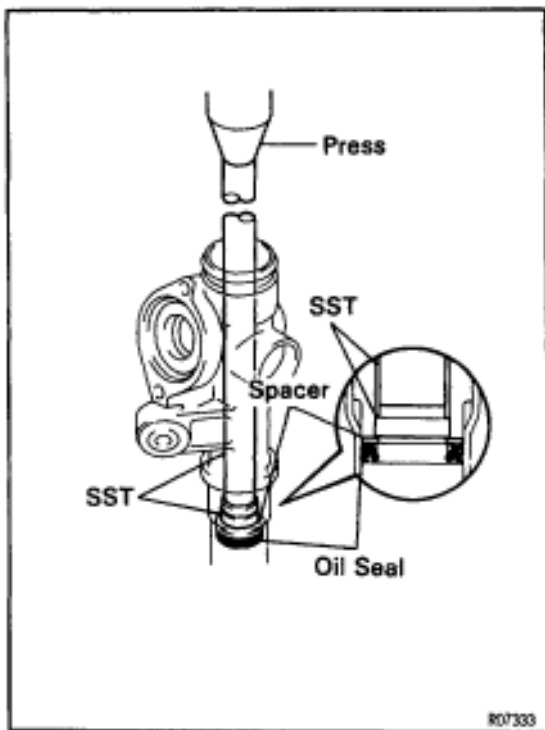
**15. REMOVE OIL SEAL AND SPACER**

Using SST and a press, press out the oil seal and spacer.  
SST 09631-12020, 09631-20031

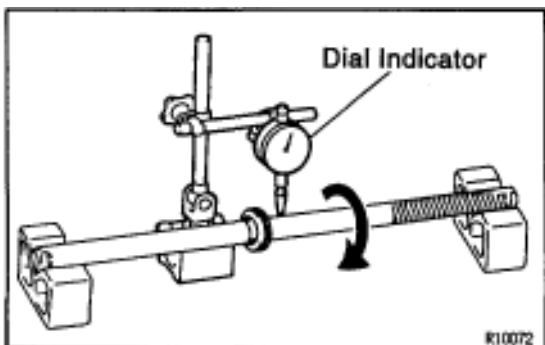
**POWER STEERING GEAR INSPECTION AND REPLACEMENT**

**NOTICE:** When using a vise, do not overtighten it.

**1. INSPECT STEERING RACK**

- (a) Using a dial indicator, check the rack for runout and for teeth wear or damage.

	Runout	mm (in.)
Maximum	0.30 mm	(0.0118 in.)

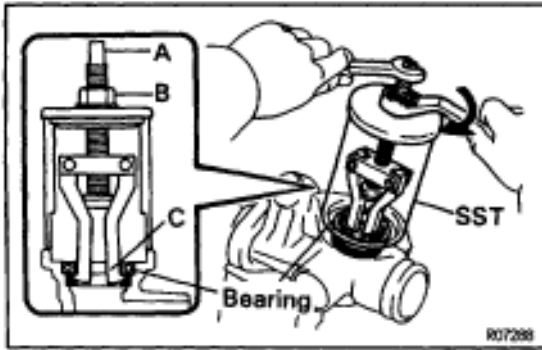

- (b) Check the back surface for wear or damage.
- 2. IF NECESSARY, REPLACE BEARING AND OIL SEAL**
- (a) Set SST to the rack housing, as shown.  
SST 09612-30012
- (b) Turn A clockwise and engage the tips of C on the bearing.
- (c) Using a spanner (8 mm), keep A fixed while turning nut B clockwise, and remove the bearing.

**NOTICE: Be careful not to damage the rack housing.**

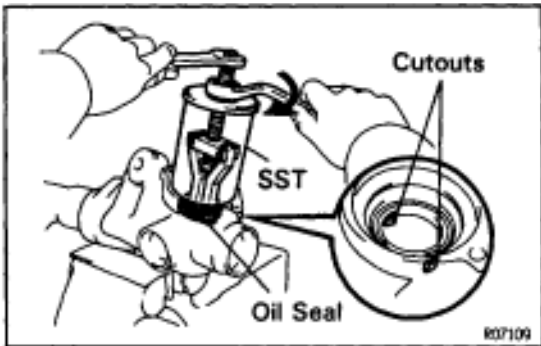

- (d) Using SST, remove the oil seal from the rack housing.  
SST 09612-30012
- NOTICE: Be careful not to damage the rack housing.**
- HINT: When using SST, apply the tips of SST to the cutouts in the rack housing.

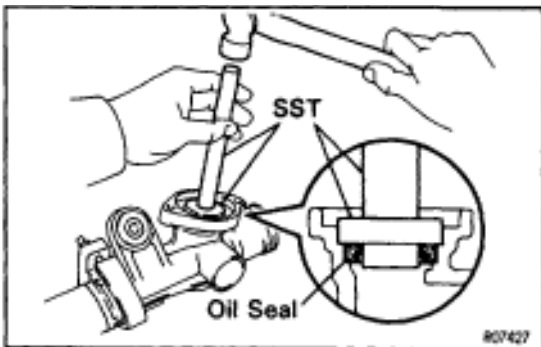

- (e) Coat a new oil seal lip with power steering fluid.
- (f) Using SST, install the oil seal.  
SST 09620-30010 (09624-30010, 09631-00020)
- NOTICE: Make sure you install the oil seal facing the correct direction.**

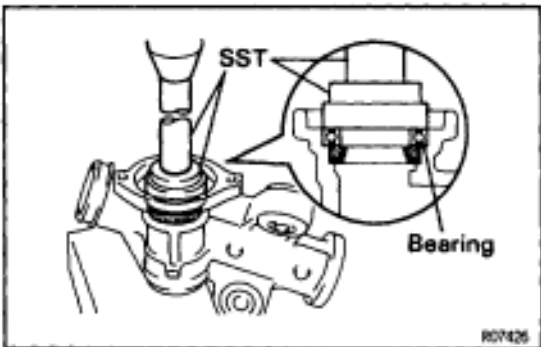

- (g) Using SST and a press, press in a new bearing.  
SST 09620-30010 (09626-30010, 09631-00020)

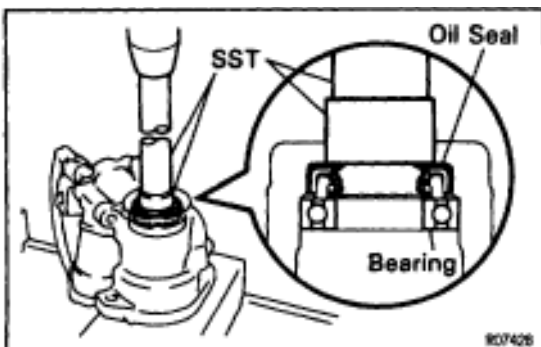

- 3. IF NECESSARY, REPLACE OIL SEAL AND BEARING**
- (a) Using SST and a press, press out the oil seal with the bearing from the control valve housing.  
SST 09620-30010 (09631-00020)  
09630-24013 (09620-24010)

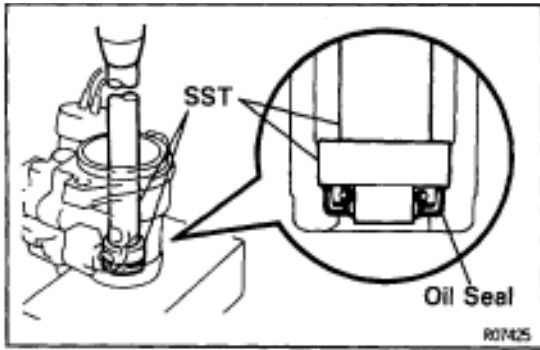

- (b) Coat a new oil seal lip with power steering fluid.
- (c) Using SST and a press, press in the oil seal.  
SST 09620-30010 (09631-00020)  
09630-24013 (09620-24020)

**NOTICE: Make sure you install the oil seal facing the correct direction.**

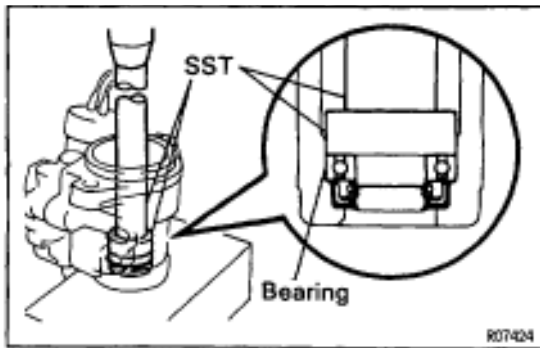

- (d) Using SST and a press, press in a new bearing.  
SST 09620-30010 (09631-00020)  
09630-24013 (09620-24030)

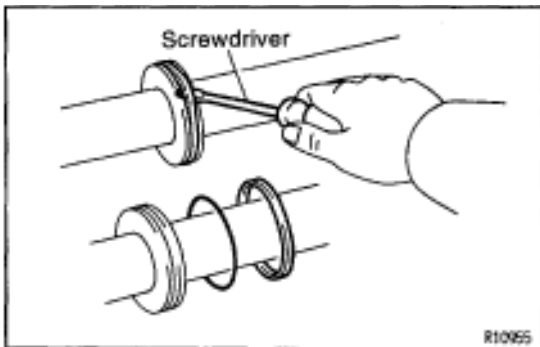

#### 4. IF NECESSARY, REPLACE TEFLON RING AND O-RING

- (a) Using a screwdriver, remove the teflon ring and O-ring.  
**NOTICE: Be careful not to damage the groove for the teflon ring.**
- (b) Coat a new O-ring with power steering fluid and install it.

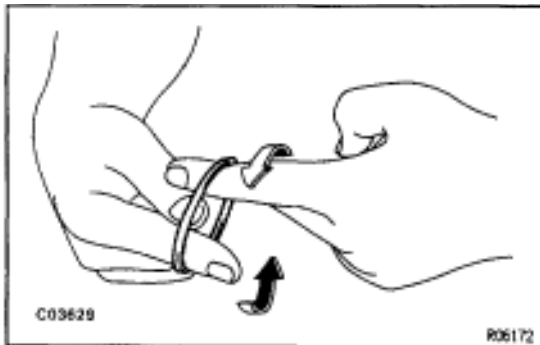

- (c) Expand a new teflon ring with your fingers.  
**NOTICE: Be careful not to over-expand the ring.**

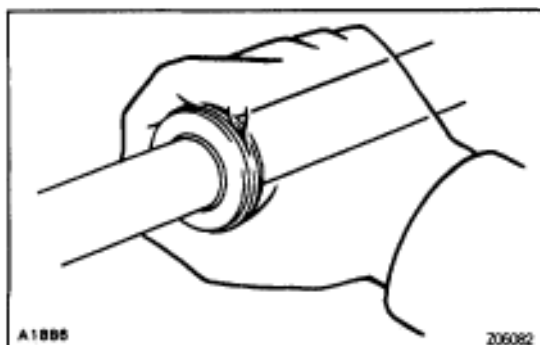

- (d) Install the teflon ring to the rack.
- (e) Coat the teflon ring with power steering fluid, and snug it down with your fingers.



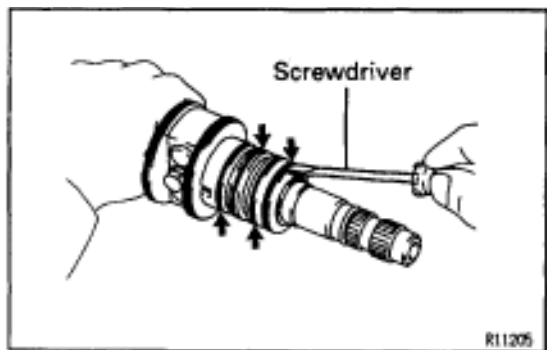

#### 5. IF NECESSARY, REPLACE TEFLON RINGS

- (a) Using a screwdriver, remove the 4 rings from the control valve assembly.

**NOTICE: Be careful not to damage the grooves for the ring.**

- (b) Expand 4 new rings with your fingers.

**NOTICE: Be careful not to over-expand the ring.**

- (c) Install the 4 rings.

- (d) Coat the 4 rings with power steering fluid and snug them down with your fingers.

- (e) Carefully slide the tapered end of SST over the rings to seal them.

SST 09631-20081

**NOTICE: Be careful not to damage the rings.**

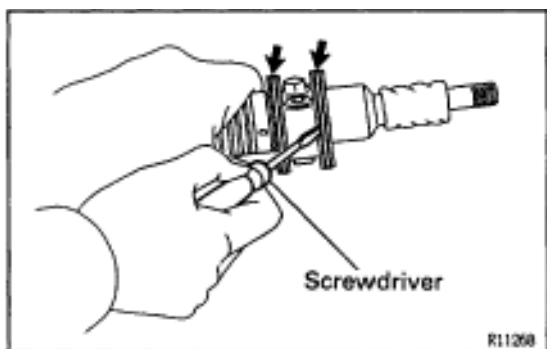
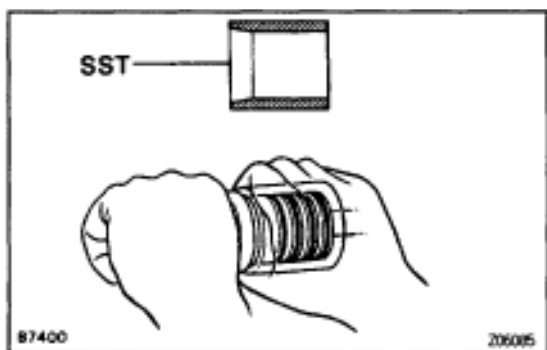

#### 6. IF NECESSARY, REPLACE TEFLON RINGS AND O-RINGS

- (a) Using a screwdriver, remove the 2 teflon rings and O-rings from the control valve assembly.

**NOTICE: Be careful not to damage the grooves for the teflon ring.**

- (b) Coat 2 new O-rings with power steering fluid, and install them.

- (c) Expand 2 new teflon rings with your fingers.

**NOTICE: Be careful not to over-expand the teflon rings.**

- (d) Install the 2 teflon rings.

- (e) Coat the teflon rings with power steering fluid, and snug them down with your fingers.

- (f) Carefully slide the tapered end of SST over the teflon rings to seal them.

SST 09631-32020

**NOTICE: Be careful not to damage the teflon rings.**

#### 7. IF NECESSARY, REPLACE PRESSURE CONTROL VALVE ASSEMBLY

- (a) Using a hexagon wrench (6 mm), remove the 3 bolts.

- (b) Remove the 3 O-rings from the control valve housing.

- (c) Coat 3 new O-rings with power steering fluid, and install them.

- (d) Using a hexagon wrench (6 mm), install a new valve assembly with the 3 bolts.

**Torque: 18 N·m (185 kgf·cm, 13 ft·lbf)**

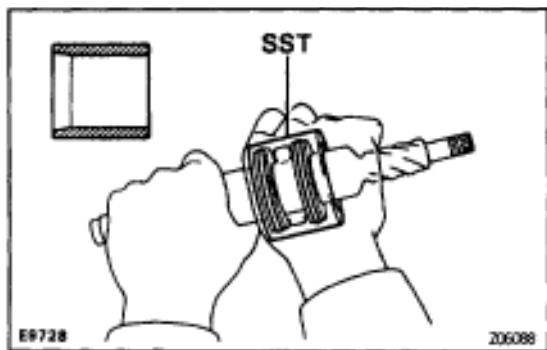

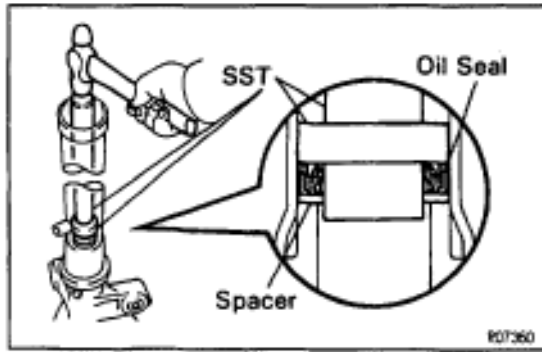

## POWER STEERING GEAR ASSEMBLY

**NOTICE:** When using a vise, do not overtighten it.

1. **COAT WITH POWER STEERING FLUID OR MOLYBDENUM DISULPHIDE LITHIUM BASE GREASE**  
(See page [SR-34](#) and [SA-35](#))

2. **INSTALL SPACER AND OIL SEAL**

- (a) Coat a new oil seal lip with power steering fluid.
- (b) Using SST and a hammer, softly tap in the oil seal.  
SST 09631-12020, 09631-22070

**NOTICE:**

- Make sure you install the oil seal facing the correct direction.
- Take care that the oil seal does not get reversed as you install it.

3. **INSTALL STEERING RACK**

- (a) Install SST to the rack.

**HINT:** If necessary, scrape the burrs off the rack teeth end and burnish.

SST 09631-20102

- (b) Coat SST with power steering fluid.
- (c) Install the rack into the cylinder.
- (d) Remove SST.

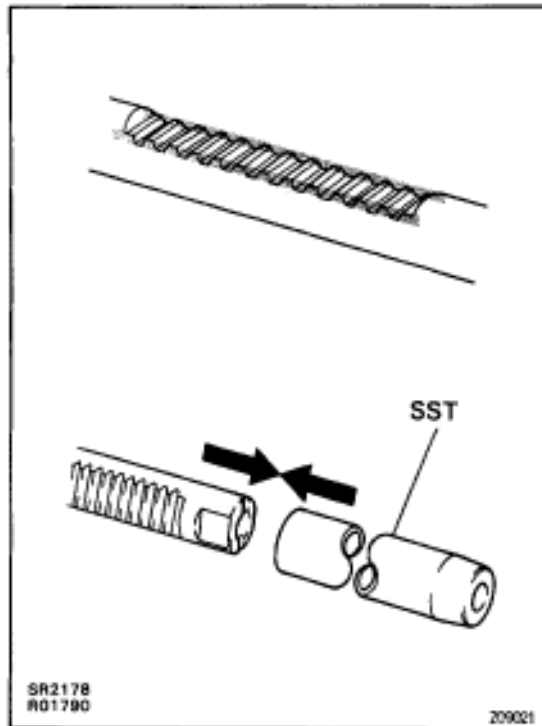

4. **INSTALL OIL SEAL**

- (a) To prevent oil seal lip damage, wind vinyl tape on the steering rack, and apply power steering fluid.
- (b) Coat a new oil seal lip with power steering fluid.
- (c) Install the oil seal by pushing it into the rack housing without tilting.

**NOTICE:** Make sure you install the oil seal facing the correct direction.

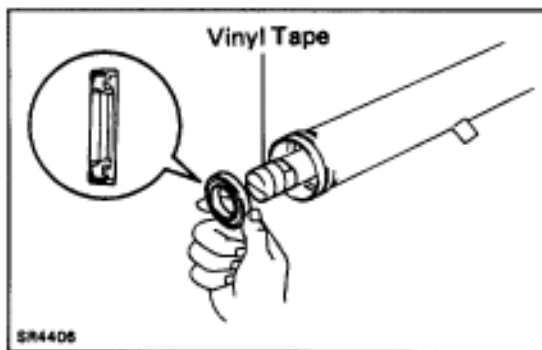

5. **INSTALL 2 SPACERS AND CYLINDER END STOPPER**

- (a) Using SST, drive in the stopper.

SST 09620-30010 (09627-30010, 09631-00020)

- (b) Using snap ring pliers, install a new snap ring to the rack housing.

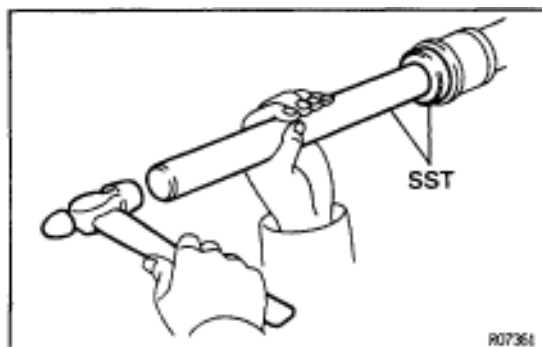

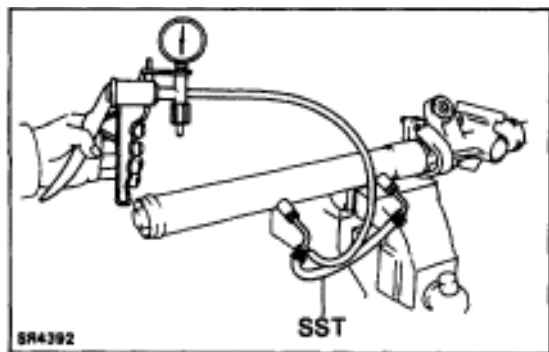

## 6. AIR TIGHTNESS TEST

- (a) Install SST to the unions of the rack housing.  
SST 09631-12071

**NOTICE: Do not install union seats.**

- (b) Apply 53.3 kPa (400 mmHg, 15.75 in.Hg) of vacuum for about 30 seconds.
- (c) Check that there is no change in the vacuum.  
If there is change in the vacuum, check the installation of the oil seals.

## 7. INSTALL CONTROL VALVE ASSEMBLY

- (a) Coat the teflon rings, with power steering fluid.
- (b) Push the valve assembly into the rack housing.

## 8. INSTALL CONTROL VALVE HOUSING

- (a) Coat a new O-ring with power steering fluid, and install it to the housing.
- (b) To prevent oil seal lip damage, wind vinyl tape on the serrated part of the control valve shaft.
- (c) Using a hexagon wrench (6 mm), torque the 2 bolts.

**Torque: 18 N·m (185 kgf·cm, 13 ft·lbf)**

## 9. INSTALL SPACER, BEARING AND SELFLOCKING NUT

Using SST to stop the control valve shaft rotating, torque a new nut.

SST 09616-00010

**Torque: 39 N·m (400 kgf·cm, 29 ft·lbf)**

## 10. INSTALL RACK HOUSING CAP

- (a) Apply sealant to 2 or 3 threads of the cap.

**Sealant:**

**Part No. 08833-00080, THREE BOND 1344, LOCTITE 242 or equivalent**

- (b) Torque the cap.

**Torque: 69 N·m (700 kgf·cm, 50 ft·lbf)**

## 11. INSTALL RACK GUIDE SEAT, RACK GUIDE, RACK GUIDE SPRING AND RACK GUIDE SPRING CAP

- (a) Install the seat to the guide.
- (b) Apply sealant to 2 or 3 threads of the cap.

**Sealant:**

**Part No. 08833-00080, THREE BOND 1344, LOCTITE 242 or equivalent**

- (c) Temporarily install the cap.

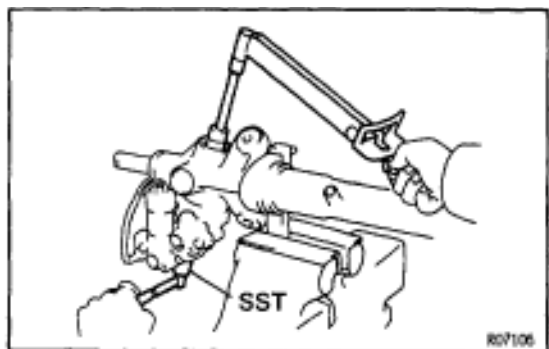

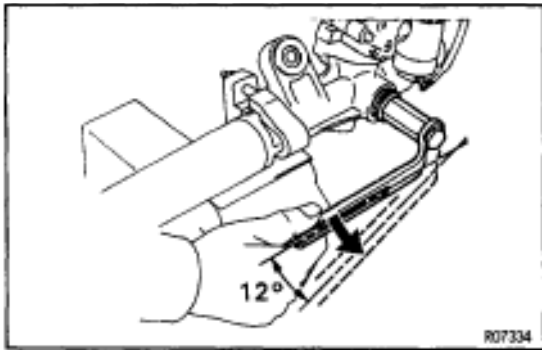

## 12. ADJUST TOTAL PRELOAD

- (a) Using a hexagon wrench (24 mm), torque the rack guide spring cap.

**Torque: 25 N·m (250 kgf·cm, 18 ft·lbf)**

- (b) Using a hexagon wrench (24 mm), return the cap 125  
 (c) Using SST, turn the control valve shaft right and left 1 or 2 times.

SST 09616-00010

- (d) Using a hexagon wrench (24 mm), loosen the cap until the rack guide spring is not functioning.

- (e) Using SST, a torque wrench and hexagon wrench (24 mm), tighten the cap until the preload is within specification.

SST 09616-00010

**Preload (turning):**

**1.0-1.9 N·m (10-20 kgf·cm, 8.7-17.4 in.·lbf)**

## 13. INSTALL RACK GUIDE SPRING CAP LOCK NUT

- (a) Apply sealant to 2 or 3 threads of the nut.

**Sealant:**

**Part No. 08833-00080, THREE BOND 1344, LOCTITE 242 or equivalent**

- (b) Using SST and hexagon wrench (24 mm), torque the nut.  
 SST 09922-10010

**Torque: 56 N·m (567 kgf·cm, 41 ft·lbf)**

**NOTICE: Use SST 09922-10010 in the direction shown in the illustration.**

**HINT: Use a torque wrench with a fulcrum length of 340 mm (13.39 in.)**

- (c) Recheck the total preload.

**Preload (turning):**

**1.0-1.9 N·m (10-20 kgf·cm, 8.7-17.4 in.·lbf)**

## 14. INSTALL DUST COVER

## 15. INSTALL RH AND LH CLAW WASHERS AND RACK ENDS

- (a) Install a new washer, and temporarily install the rack end.

**HINT: Align the claws of the washer with the rack grooves.**

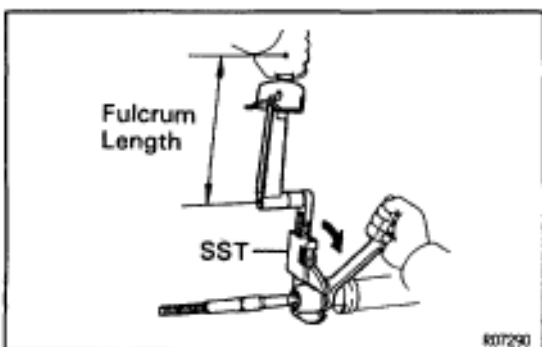
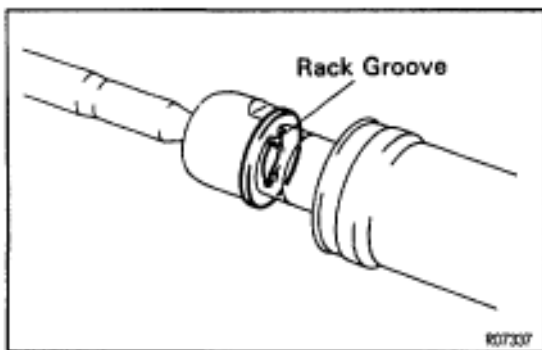
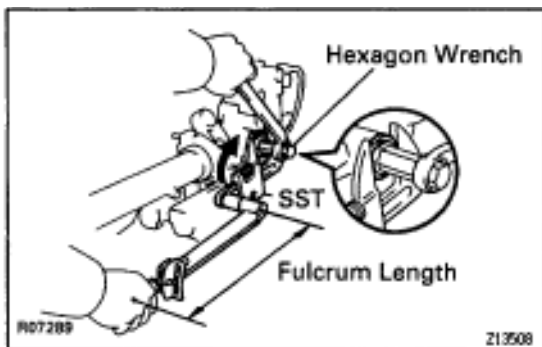
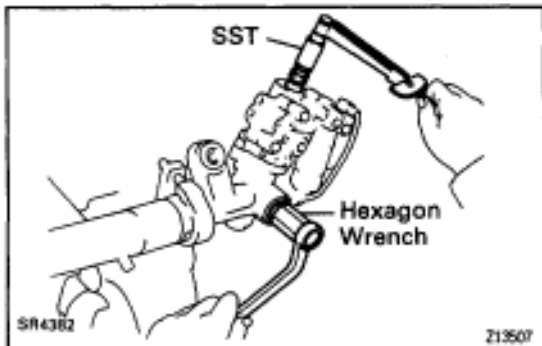

- (b) Using a spanner (22 mm) to hold the steering rack, and using SST, torque the rack end.

SST 09922-10010

**Torque: 90 N·m (914 kgf·cm, 66 ft·lbf)**

**NOTICE: Use SST 09922-10010 in the direction shown in the illustration.**

**HINT: Use a torque wrench with a fulcrum length of 380 mm (14.96 in.)**

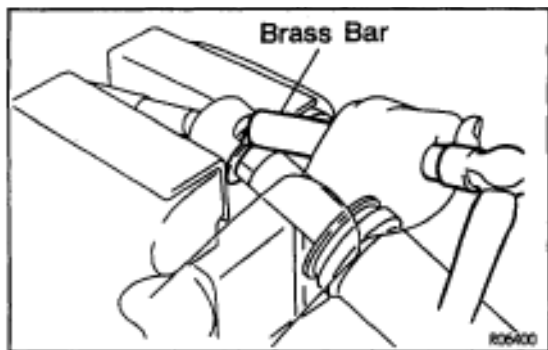

- (c) Using a brass bar and hammer, stake the washer.  
**NOTICE: Avoid any impact to the rack.**

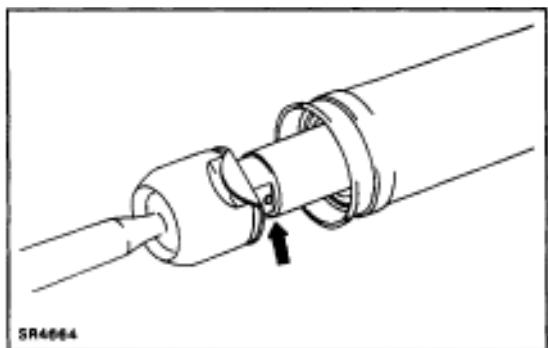

## 16. INSTALL RH AND LH RACK BOOTS, CLAMPS AND CLIPS

- (a) Ensure that the steering rack hole is not clogged with grease.  
**HINT:** If the hole is clogged, the pressure inside the boot will change after it is assembled and the steering wheel turned.
- (b) Install the boot.  
**NOTICE: Be careful not to damage or twist the boot.**

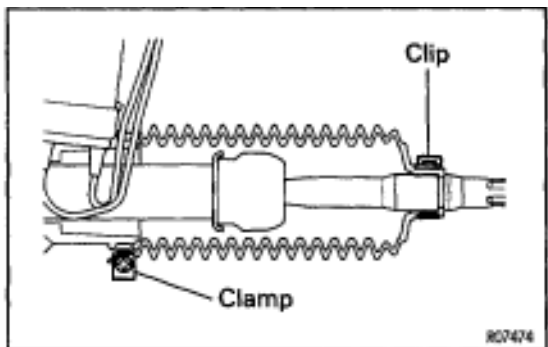

- (c) Install the clamp and clip to the boot.  
**HINT:** When the rack guide spring cap is towards you, install the clip and clamp in the positions shown in the illustration.

## 17. INSTALL TIE ROD ENDS

- (a) Screw the lock nut and tie rod end onto the rack end until the matchmarks are aligned.
- (b) After adjusting toe-in, torque the nut.  
**Torque: 56 N·m (570 kgf·cm, 41 ft·lbf)**

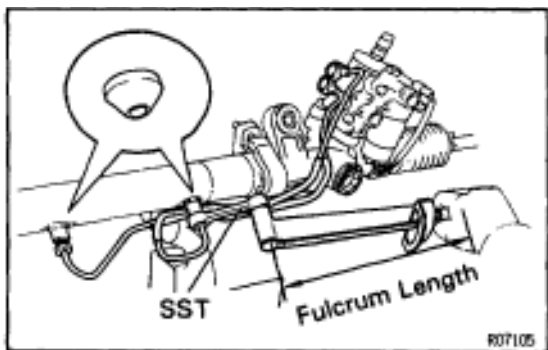

## 18. INSTALL TURN PRESSURE TUBES

- (a) Install 2 new union seats.
- (b) Using SST, install the 2 tubes.  
SST 09633-00020  
**Torque: 24 N·m (243 kgf·cm, 17 ft·lbf)**  
**HINT:** Use a torque wrench with a fulcrum length of 300 mm (11.81 in.)
- (c) Torque the 2 union bolts over 4 new gaskets.  
**Torque: 34 N·m (350 kgf·cm, 25 ft·lbf)**

# POWER STEERING GEAR INSTALLATION

## 1. INSTALL POWER STEERING GEAR ASSEMBLY

- (a) Temporarily install the 2 bolts and nuts.
- (b) After installing the rack housing bracket and grommet, torque the 2 bolts and nuts.  
**Torque: 75 N·m (770 kgf·cm, 55 ft·lbf)**

2. **INSTALL RACK HOUSING BRACKET AND GROMMET**  
Torque the 2 bolts and nuts.  
Torque: 75 N·m (770 kgf·cm, 55 ft·lbf)
3. **CONNECT PPS SOLENOID CONNECTOR**
4. **CONNECT PRESSURE FEED TUBE**  
Torque the union bolt over a new gasket.  
Torque: 49 N·m (500 kgf·cm, 36 ft·lbf)
5. **CONNECT RETURN TUBE**  
Torque the union bolt over 2 new gaskets.  
Torque: 49 N·m (500 kgf·cm, 36 ft·lbf)
6. **CONNECT RH AND LH TIE ROD ENDS**  
(See page [SA-17](#))
7. **CONNECT INTERMEDIATE SHAFT**  
(See page [SR-21](#))
8. **INSTALL FR SUSPENSION MEMBER PROTECTOR**  
Torque the 4 bolts.
9. **INSTALL ENGINE UNDER COVER**  
Install the 10 screws.
10. **BLEED POWER STEERING SYSTEM**  
(See page [SR-9](#))
11. **CHECK FRONT WHEEL ALIGNMENT**  
(See page [SA-4](#))

# ELECTRONIC CONTROL SYSTEM

## TROUBLESHOOTING FLOW-CHART

### Trouble Symptom

- Hard steering at idle or low-speed driving.
- Steering too sensitive during high-speed driving.

### Preliminary Check

- Check tire pressure.
- Check lubrication of suspension and steering linkage.
- Check front wheel alignment.
- Check steering system joint and suspension arm ball joint.
- Check for bent steering column.
- Check that all connectors are secure.
- Check PS pump fluid pressure. (See page [SR-37](#))

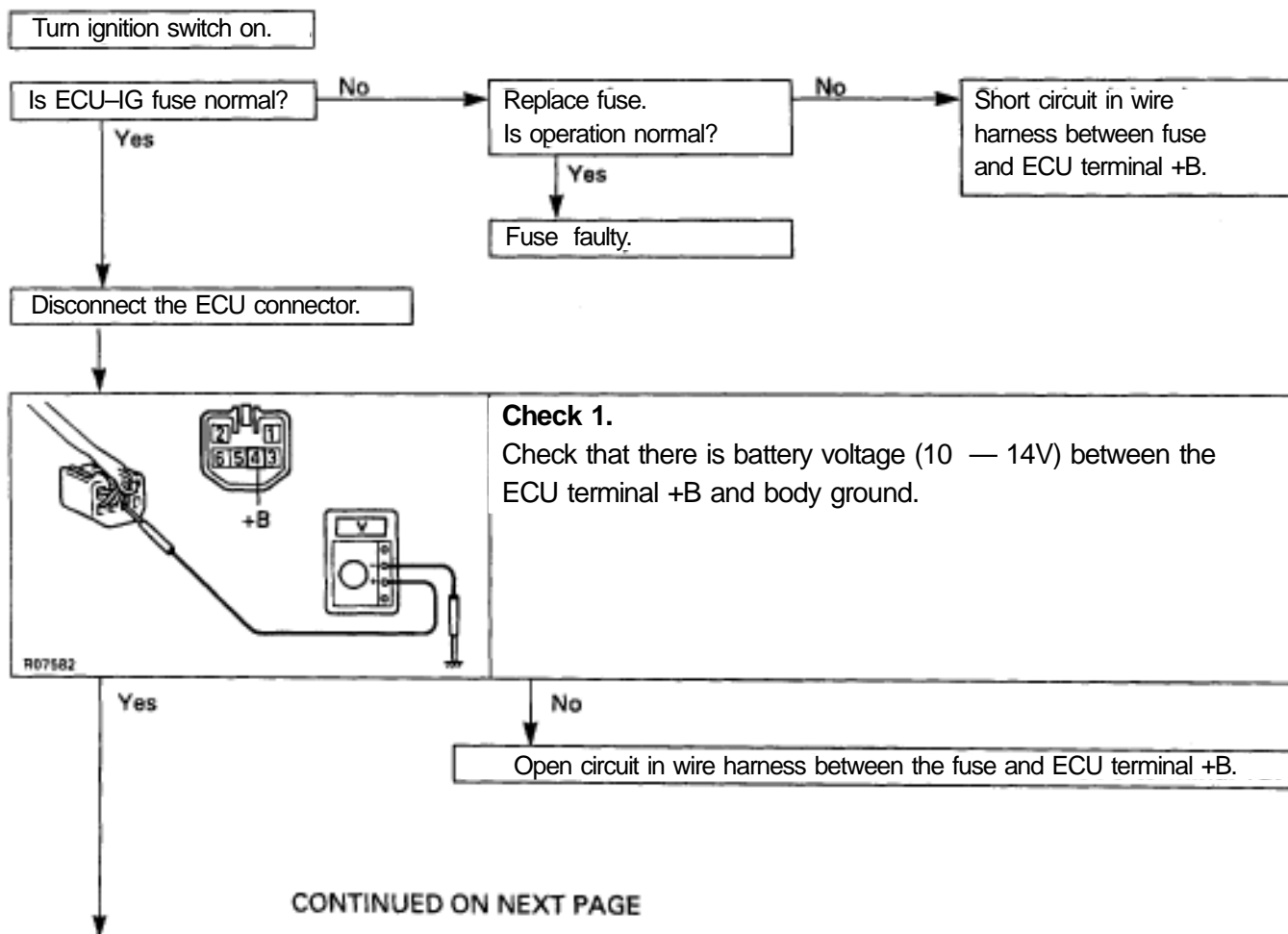

Yes

CONTINUED FROM PREVIOUS PAGE

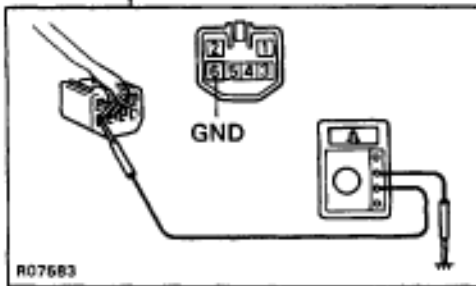
**Check 2.**

Check that there is continuity between the ECU terminal GND and body ground.

Yes

No

- Open circuit in wire harness between the ECU terminal GND and body ground.
- Body ground faulty.

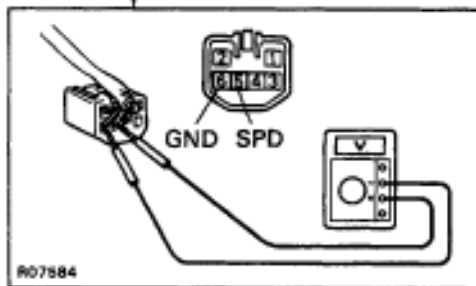
**Check 3.**

- Jack up one of the rear wheels.
- Connect a voltmeter between the ECU connector terminals SPD and GND.
- Spin the rear wheel and check that the meter needle deflects 0 V → 5 V or more → 0 V.

Yes

No

- Open or short circuit in wire harness between the ECU terminal SPD and speed sensor.
- Speed sensor faulty (See BE section.)

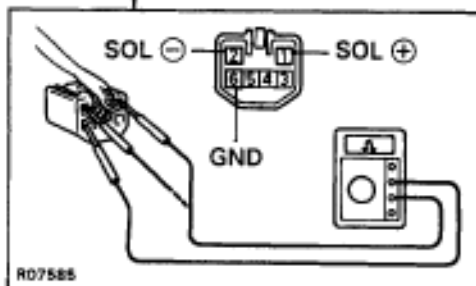
**Check 4.**

Check that there is no continuity between terminals SOL (+) or SOL (-) and GND.

Yes

No

- Short circuit in wire harness between the terminals SOL (+) and SOL (-).
- Solenoid valve faulty.

CONTINUED ON NEXT PAGE



CONTINUED FROM PREVIOUS PAGE

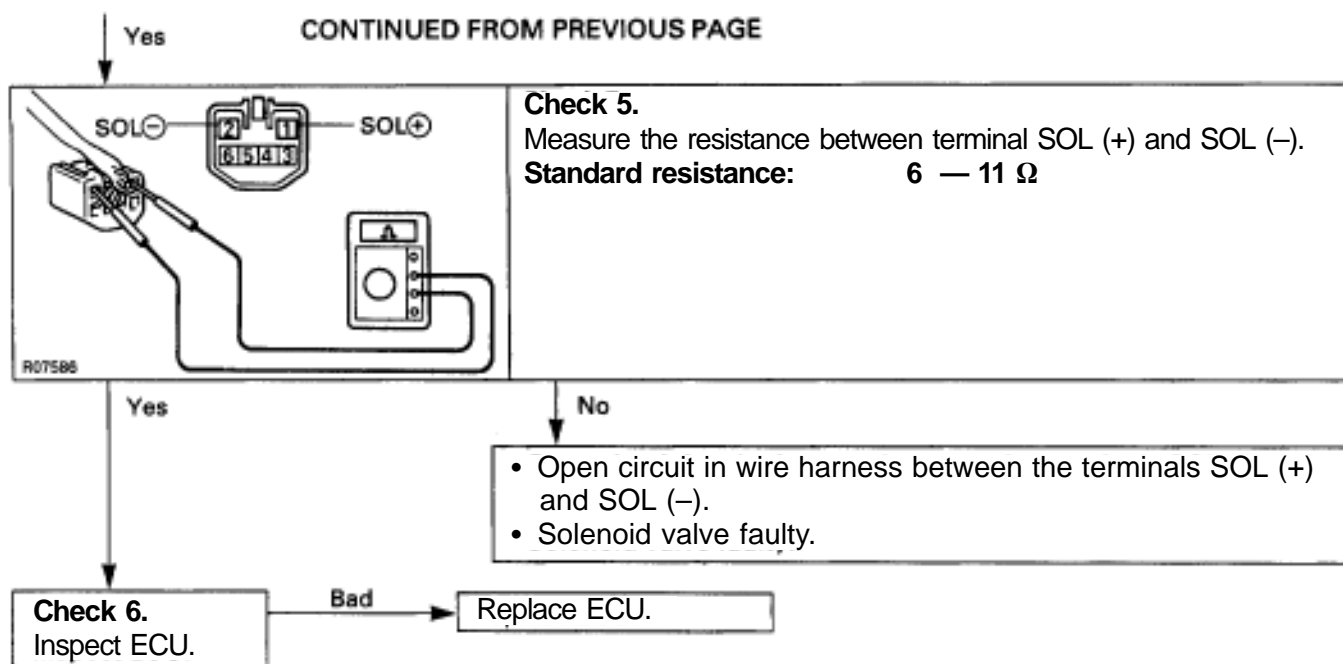

V05684

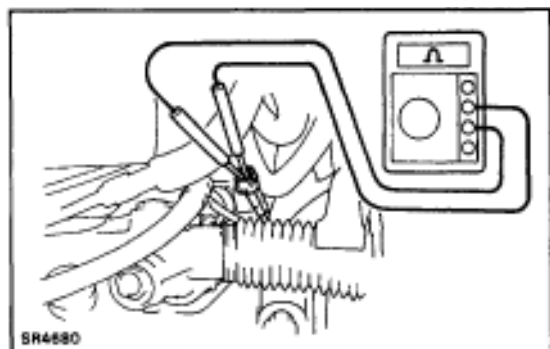

## PPS SOLENOID VALVE INSPECTION

### 1. DISCONNECT PPS SOLENOID CONNECTOR (See page SR-33)

### 2. MEASURE RESISTANCE

Measure the resistance between SOL  $\oplus$  and SOL  $\ominus$ .

**Resistance:**

6-11  $\Omega$

### 3. CHECK PPS SOLENOID OPERATION

- Connect the battery positive terminal to the solenoid terminal SOL  $\oplus$ .
- Connect the battery negative terminal to the solenoid terminal SOL  $\ominus$ .
- Check that the solenoid makes a 'clicks' sound.  
If faulty, replace the pressure control valve with the solenoid valve.

#### NOTICE:

- Do not apply voltage for more than 30 seconds to avoid burning out the solenoid.
- If repeating this step, wait until the solenoid cools down enough that it can be touched by hand.

### 4. CONNECT PPS SOLENOID CONNECTOR

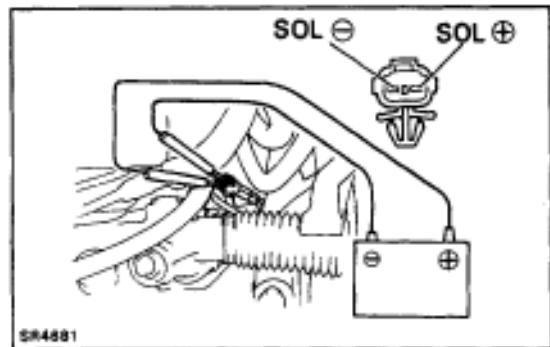

## PPS ECU INSPECTION

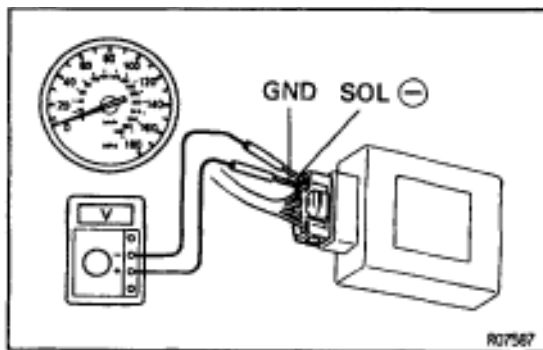
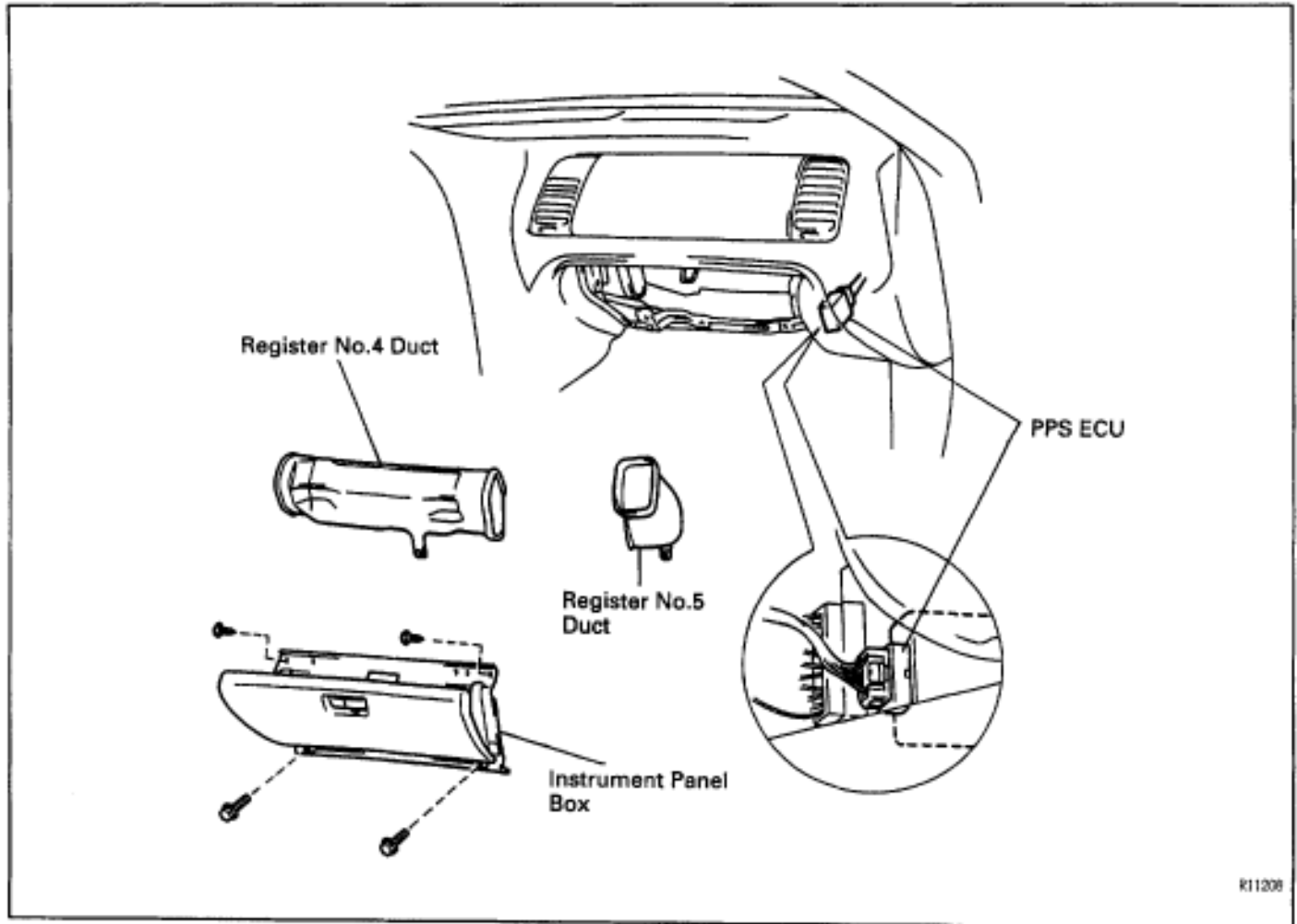

1. JACK UP VEHICLE AND SUPPORT IT ON STANDS
2. START ENGINE
3. MEASURE VOLTAGE OF ECU

(a) Using a voltmeter, measure the voltage between ECU terminals SOL ⊖ and GND while the engine is idling.

**Standard voltage:**

**0.15–0.20 V**

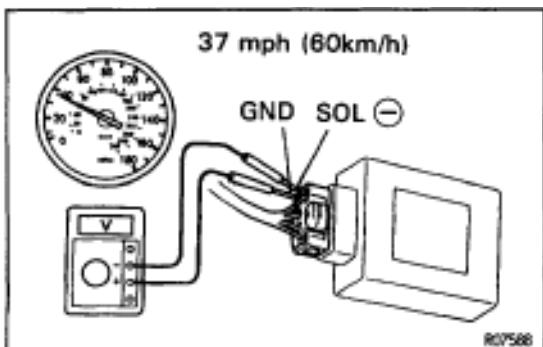

(b) Place the transmission in gear and while running at about 37 mph (60 km/h), measure the voltage between ECU terminals SOL ⊖ and GND.

**Standard voltage:**

**Voltage measured in (a) above, minus**

**2JZ-GE: 0.02–0.08 V**

**2JZ-GTE: 0.01–0.07 V**

If no voltage, try another ECU.

4. LOWER VEHICLE

# SERVICE SPECIFICATIONS

## SERVICE DATA

Steering wheel freeplay	Maximum	30 mm (1.18 in.)
STEERING COLUMN		
Pawl stopper	Mark	
	1 or A	12.68–12.74 mm (0.4992–0.5016 in.)
	2 or B	12.61–12.67 mm (0.4965–0.4988 in.)
	3 or C	12.54–12.60 mm (0.4937–0.4961 in.)
	4 or D	12.47–12.53 mm (0.4909–0.4933 in.)
	5 or E	12.40–12.46 mm (0.4882–0.4906 in.)
	6 or F	12.33–12.39 mm (0.4854–0.4878 in.)
	7 or G	12.26–12.32 mm (0.4827–0.4850 in.)
PS ON-VEHICLE INSPECTION		
Maximum rise of oil level		Below 5 mm (0.20 in.)
Oil pressure at idle speed with valve closed	Minimum	7,845 kPa (80 kgf/cm <sup>2</sup> , 1,140 psi)
Steering effort at idle speed	Maximum	0.4 N·m (3.6 kgf·cm, 3.1 in.·lbf)
PS VANE PUMP		
Rotor shaft bushing oil clearance	STD	0.03–0.05 mm (0.0012–0.0020 in.)
Rotor shaft bushing oil clearance	Maximum	0.07 mm (0.0028 in.)
Vane plate to rotor groove clearance	Maximum	0.03 mm (0.0012 in.)
Vane plate height	Minimum	8.6 mm (0.339 in.)
Vane plate thickness	Minimum	1.40 mm (0.0551 in.)
Vane plate length	Minimum	14.99 mm (0.5902 in.)
Vane plate length	Rotor and cam ring mark	
	NONE	14.999–15.001 mm (0.59051–0.59059 in.)
	1	14.997–14.999 mm (0.59043–0.59051 in.)
	2	14.995–14.997 mm (0.59035–0.59043 in.)
	3	14.993–14.995 mm (0.59027–0.59035 in.)
	4	14.991–14.993 mm (0.59020–0.59027 in.)
Flow control spring length	Minimum	33 mm (1.30 in.)
Pump rotating torque		0.2 N·m (2.5 kgf·cm, 2.2 in.·lbf) or less
PS GEAR HOUSING		
Steering rack runout	Maximum	0.30 mm (0.0118 in.)
Total preload		1.0–1.9 N·m (10–20 kgf·cm, 8.7–17.4 in.·lbf)
Solenoid valve resistance		6–11 Ω

## TORQUE SPECIFICATIONS

Part tightened	N·m	kgf·cm	ft·lbf	
<b>STEERING COLUMN</b>				
Steering wheel set nut	35	360	26	
Steering wheel pad set screw	7.1	72	62 in·lbf	
Column assembly set nut	25	260	19	
Intermediate shaft x Sliding yoke	35	360	26	
Tilt memory bolt x Square nut	6.4	65	56 in·lbf	
Tilt lever assembly set screw	4.7	48	42 in·lbf	
Tilt pawl set nut	5.9	60	52 in·lbf	
Tilt lever retainer set nut	15	150	11	
Tilt memory bolt set nut	5.9	60	52 in·lbf	
Turn signal bracket set bolt	8.8	90	78 in·lbf	
Sliding yoke	35	360	26	
Compression set screw	6.4	65	56 in·lbf	
<b>PS VANE PUMP</b>				
PS vane pump set bolt	58	590	42	
Union bolt	49	500	36	
Vane pump pulley set nut	43	440	32	
Front housing x Rear housing	17	170	12	
Pressure port union	83	850	61	
Oil reservoir set bolt (2JZ-GE)	Front side bolt	13	130	9
	Rear side bolts	17	170	12
Suction port union set bolt (2JZ-GTE)		13	130	9
<b>PS GEAR HOUSING</b>				
Tie rod end x Steering knuckle	49	500	36	
Control valve shaft x Intermediate shaft	35	360	26	
Pressure feed and return tube set union bolts	49	500	36	
Gear housing set bolt and nut	75	770	55	
Pressure control valve assembly x Control valve housing	18	185	13	
Control valve housing set bolt	18	185	13	
Self-locking nut	39	400	29	
Rack housing cap	69	700	501	
Rack guide spring cap lock nut	56	567	41	
Rack end	90	914	66	
Tie rod end lock nut	56	570	41	
Turn pressure tube union nut	24	243	17	
Turn pressure tube union bolt	34	350	25	