

## Check for Fluid Leakage

Check for fluid leakage from actuators or hydraulic lines.

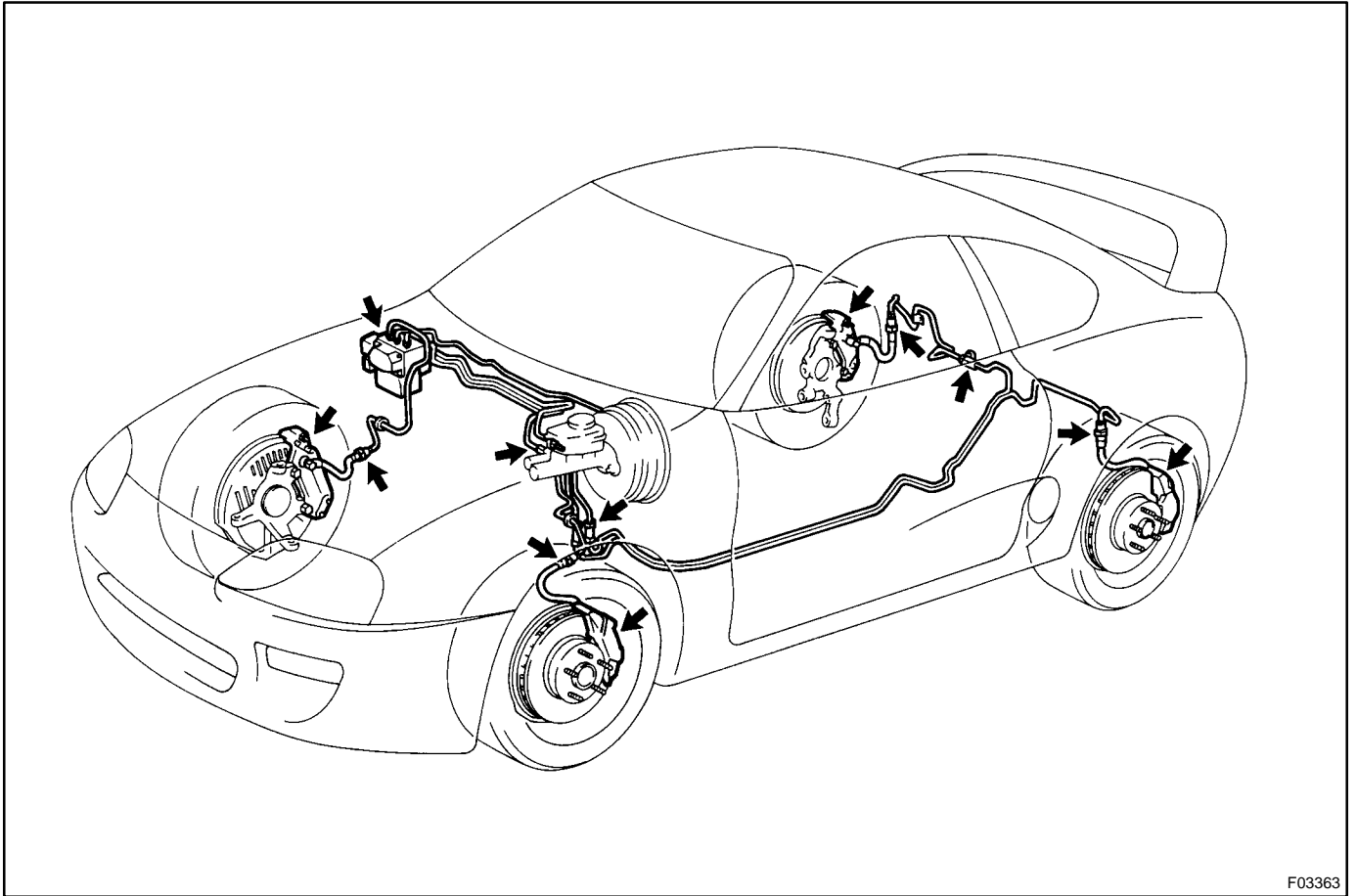

F03363

## 2. ABS

### General

The ABS (Anti-Lock Brake System) is designed to control the brake fluid pressure of the brake wheel cylinder to help prevent wheel lock-up in instances of panic braking, and thus maintaining vehicle directional stability and control.

### System Diagram

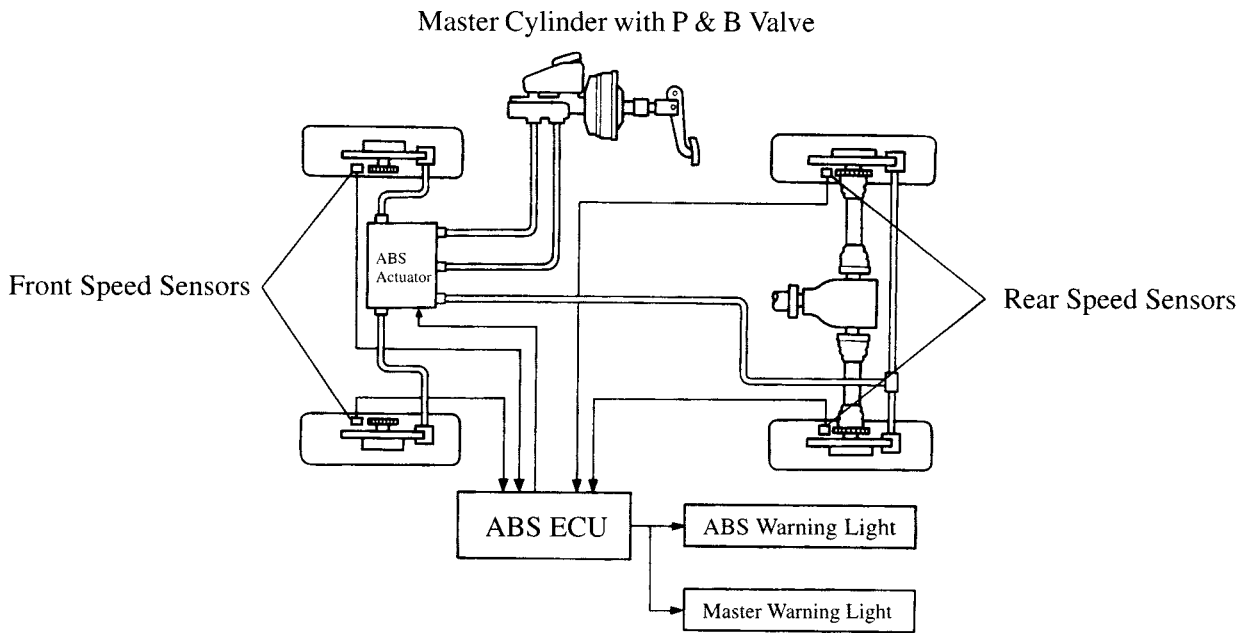

### 2JZ-GE Engine Model

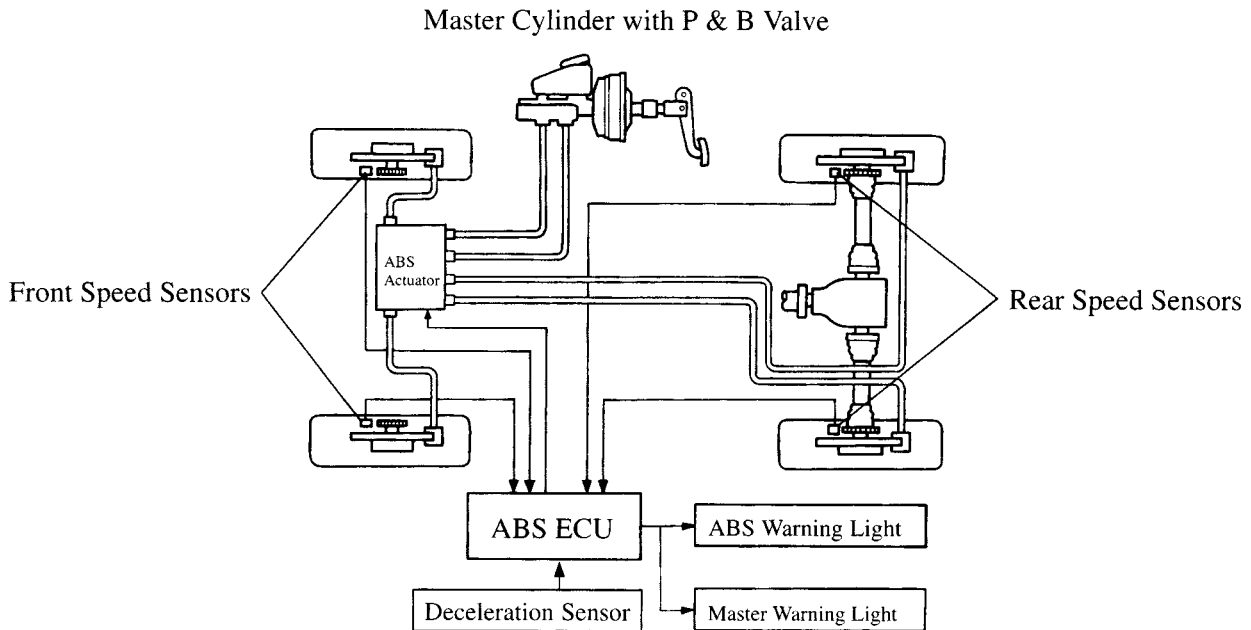

### 2JZ-GTE Engine Model

Wiring Diagram

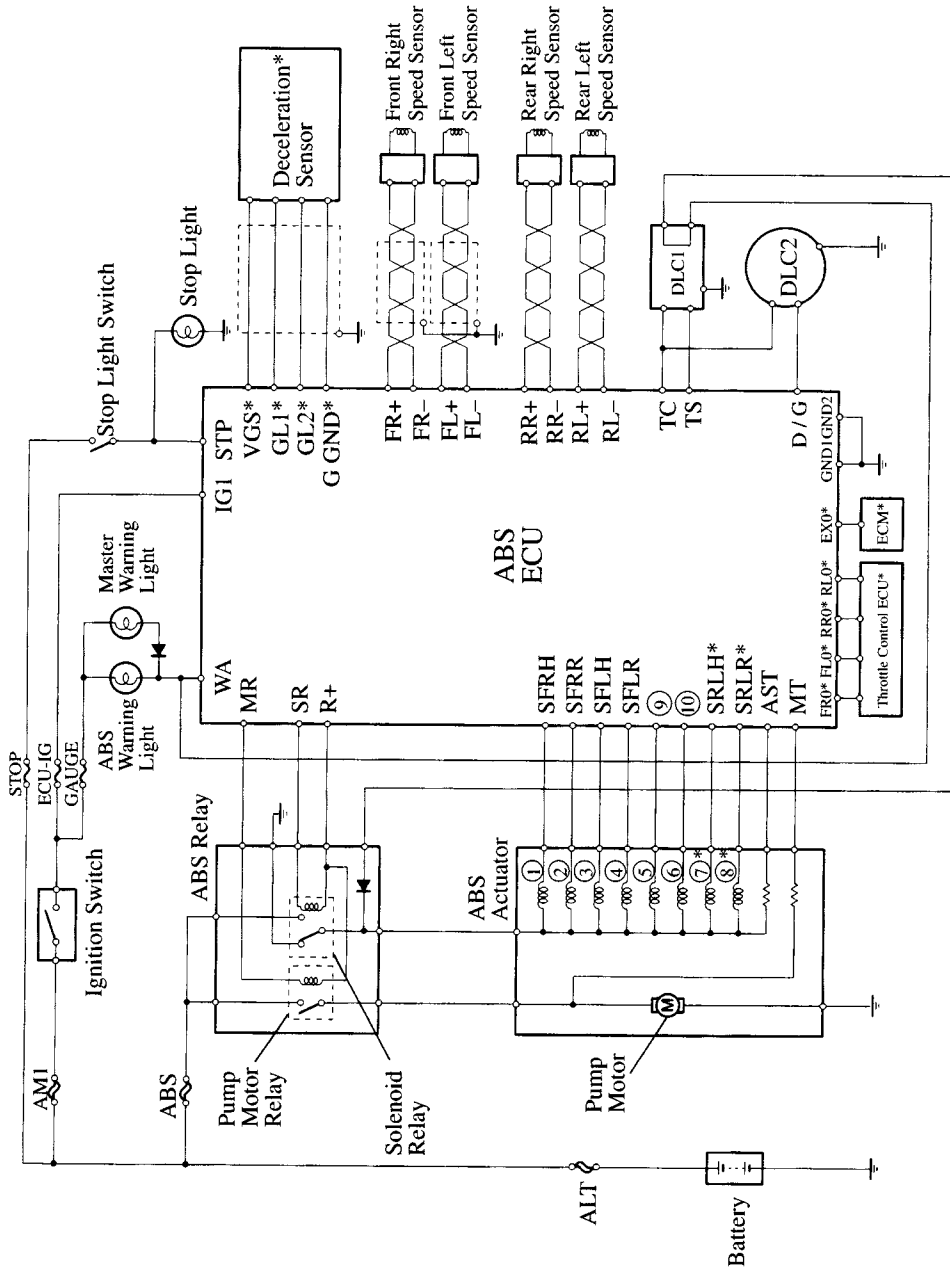

- ① Front Right Pressure Holding Valve
  - ② Front Right Pressure Reduction Valve
  - ③ Front Left Pressure Holding Valve
  - ④ Front Left Pressure Reduction Valve
  - ⑤ 2JZ-GE : Rear Pressure Holding Valve  
2JZ-GTE : Rear Right Pressure Holding Valve
  - ⑥ 2JZ-GE : Rear Pressure Reduction Valve  
2JZ-GTE : Rear Right Pressure Reduction Valve
  - ⑦ Rear Left Pressure Holding Valve
  - ⑧ Rear Left Pressure Reduction Valve
  - ⑨ 2JZ-GE : SRH, 2JZ-GTE: SRRH
  - ⑩ 2JZ-GE : SRR, 2JZ-GTE: SRRR
- \*: Only 2JZ-GTE Engine Model

## Layout of Components

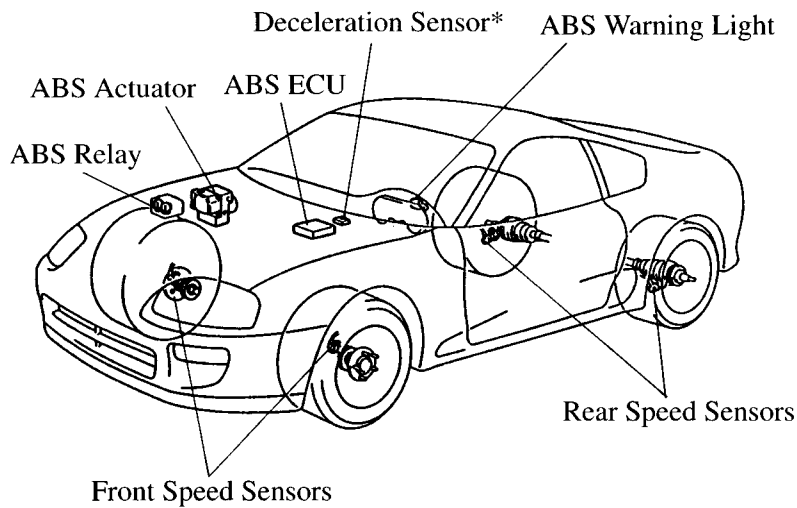

\*: Only 2JZ-GTE Engine Model

## Construction and Operation

### 1) Deceleration Sensor

The 2JZ-GTE engine model uses a linear type deceleration sensor to detect the deceleration rate in the vehicle's longitudinal direction and the acceleration rate in the vehicle's lateral direction.

Accordingly, the ABS is able to determine the vehicle's cornering condition and various road surface conditions to achieve a finely cornering control.

The basic construction and operation are the same as those of the '97 RAV4 4WD 2-door model. For details, see '96 RAV4 New Car Features (Pub. No. NCF124U), page 70.

### 2) ABS Actuator

#### a. General

The ABS actuator consists of 6 or 8 two-position solenoid valves, 2 pumps, 2 reservoirs and a motor. The table below compares the actuator against that of the '96 model.

### ► Comparison of ABS Actuators ◀

| Model         | '97 Model  |  | '96 Model                        |
|---------------|--|--|----------------------------------|
| Engine Type   | 2JZ-GE   | 2JZ-GTE  | 2JZ-GE, 2JZ-GTE                  |
| Actuator Type | 2-Position   | 2-Position   | 3-Position                       |
| Component     | Solenoid Valves  | Solenoid Valves  | Solenoid Valves                  |
| Control Unit  | 6 Two-Position Solenoid Valves (3 pressure holding valves and 3 pressure reduction valves) | 8 Two-Position Solenoid Valves (4 pressure holding valves and 4 pressure reduction valves) | 4 Three-Position Solenoid Valves |

b. Hydraulic Circuit

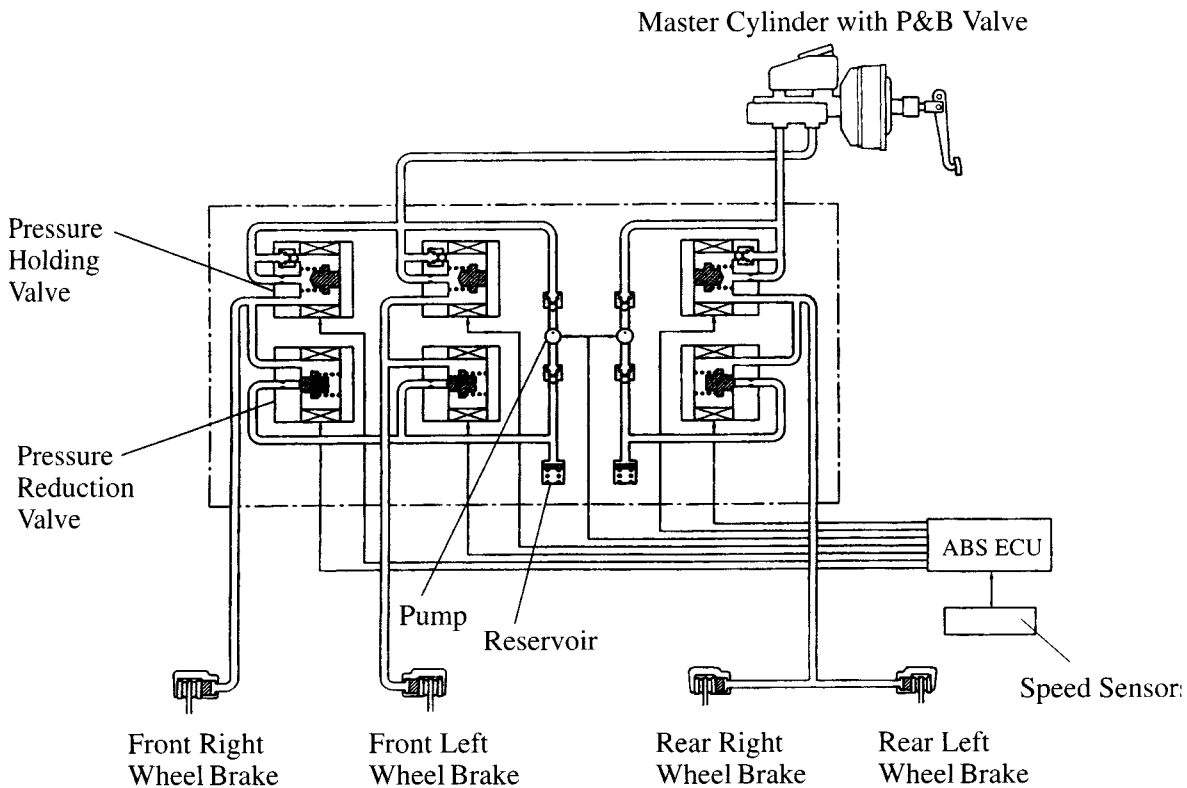

2JZ-GE Engine Model

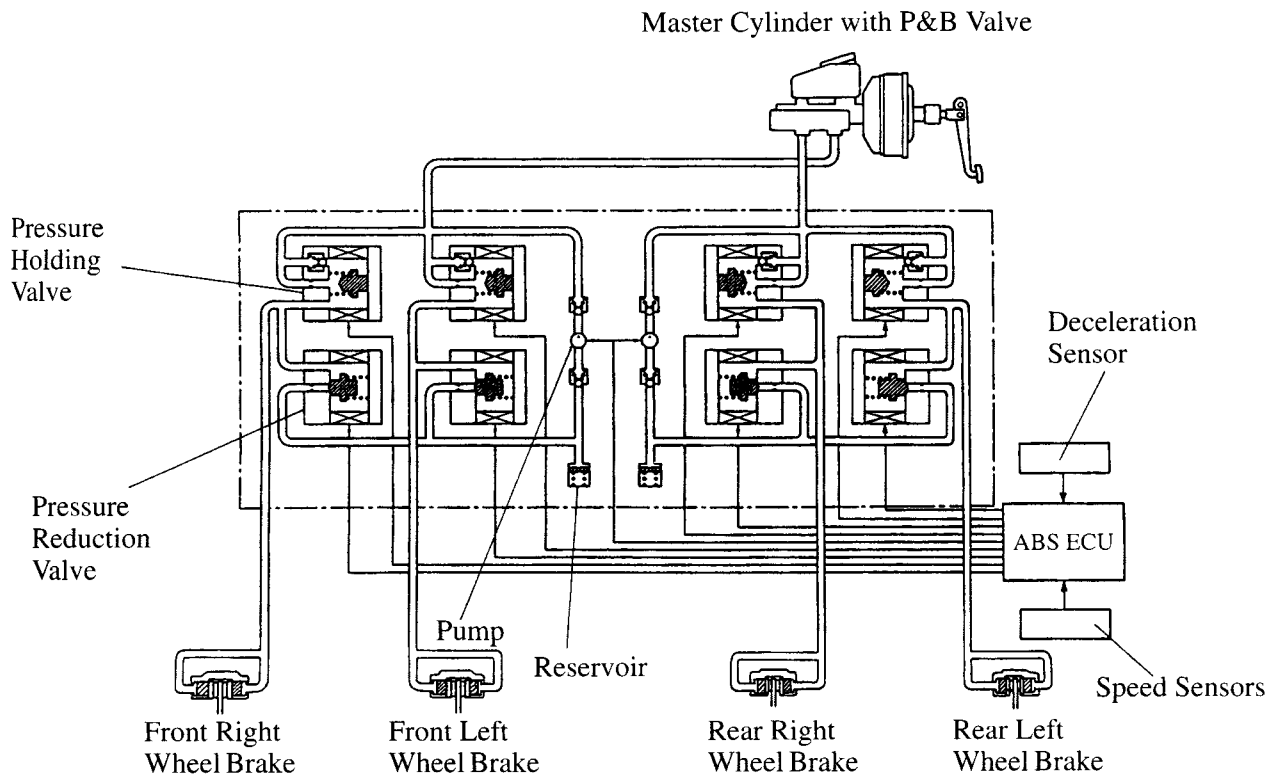

2JZ-GTE Engine Model

**c. Operation**

The hydraulic system of the ABS has 3 or 4 circuits. Although the hydraulic circuit described below has 1 circuit, it is applicable to other circuits as well.

**i) During Normal Braking (ABS not Activated)**

During normal braking, the ABS is not activated and the ECU does not send control signal.

When the brake pedal is depressed, the fluid passes from port **A** to port **B**, and then flows to the brake wheel cylinder.

When the brake pedal is released, brake fluid returns from the brake wheel cylinder to the master cylinder through port **B** to port **A** and No. 1 Check Valve.

**►Condition of Actuator◄**

| Part Name                | Signal from ABS ECU | Operation |        |
|--------------------------|---------------------|-----------|--------|
| Pressure Holding Valve   | OFF                 | Port A    | Open   |
| Pressure Reduction Valve | OFF                 | Port B    | Closed |
| Pump Motor               | OFF                 | Rotating  |        |

**►Hydraulic Circuit◄**

Master Cylinder with P&B Valve

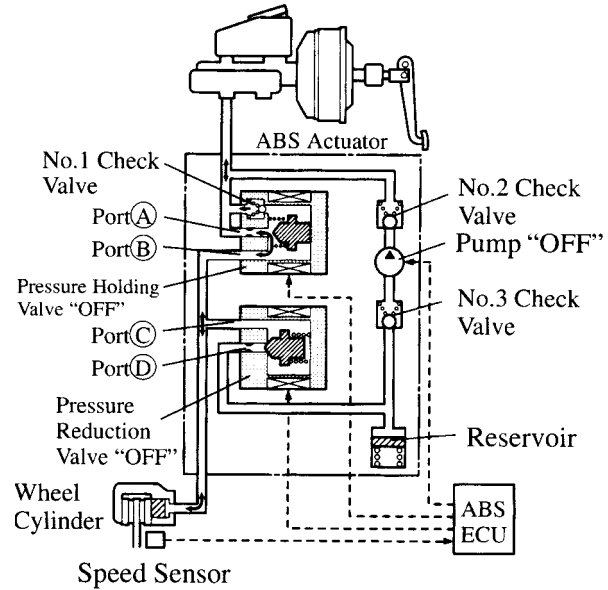

**ii) During Emergency Braking (ABS Activated)**

**• Pressure Reduction Mode**

When the wheel about to lock, the control signal from the ECU causes port **A** to close and port **D** to open, thus engaging the pressure reduction mode.

At this time the brake fluid flows from the wheel cylinder, through ports **C** and **D**, to the reservoir reducing the wheel pressure.

At the same time the brake fluid is pumped and returned to the master cylinder.

**►Condition of Actuator◄**

| Part Name                | Signal from ABS ECU | Operation |        |
|--------------------------|---------------------|-----------|--------|
| Pressure Holding Valve   | ON                  | Port A    | Closed |
| Pressure Reduction Valve | ON                  | Port D    | Open   |
| Pump Motor               | ON                  | Rotating  |        |

**►Hydraulic Circuit◄**

Master Cylinder with P&B Valve

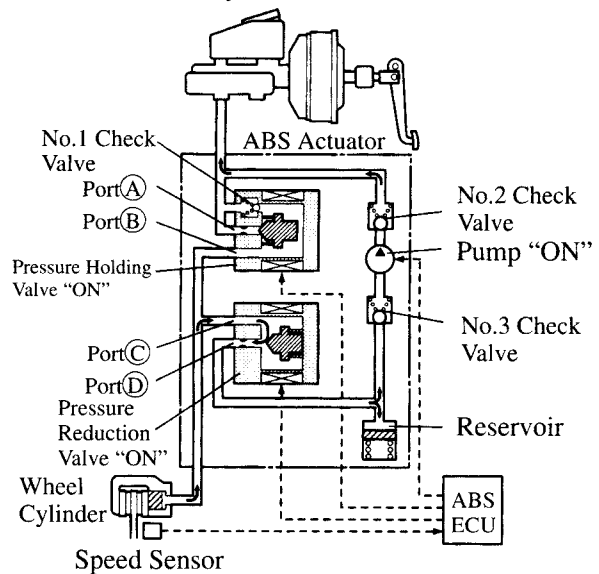

• **Pressure Holding Mode**

After the fluid pressure in the wheel cylinder is reduced or increased to the required pressure, a control signal from the ECU causes ports **A** and **D** to close. As a result, the system engages in the pressure holding mode to maintain the fluid pressure in the wheel cylinder.

► **Condition of Actuator** ◀

| Part Name                | Signal from ABS ECU | Operation |        |
|--------------------------|---------------------|-----------|--------|
| Pressure Holding Valve   | ON                  | Port A    | Closed |
| Pressure Reduction Valve | OFF                 | Port D    | Closed |
| Pump Motor               | ON                  | Rotating  |        |

► **Hydraulic Circuit** ◀

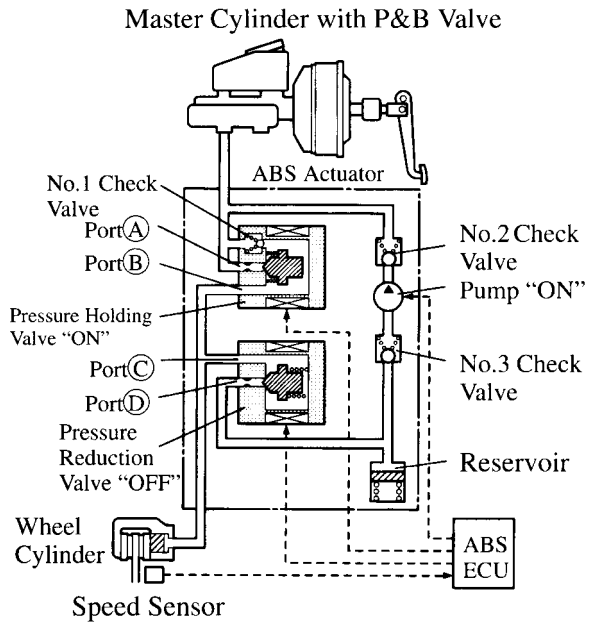

• **Pressure Increase Mode**

When the fluid pressure in the wheel needs to be increased in order to apply more braking force, a control signal from the ECU causes port **A** to open, port **D** to close, thus engaging the increase mode.

Accordingly, the circuit will be in the same state as in normal braking, in which the brake fluid is sent from the master cylinder to the wheel cylinder to increase the fluid pressure in the wheel cylinder.

The fluid pressure increase rate is controlled by repetition of the pressure increase and pressure holding mode.

► **Condition of Actuator** ◀

| Part Name                | Signal from ABS ECU | Operation |        |
|--------------------------|---------------------|-----------|--------|
| Pressure Holding Valve   | OFF                 | Port A    | Open   |
| Pressure Reduction Valve | OFF                 | Port D    | Closed |
| Pump Motor               | ON                  | Rotating  |        |

► **Hydraulic Circuit** ◀

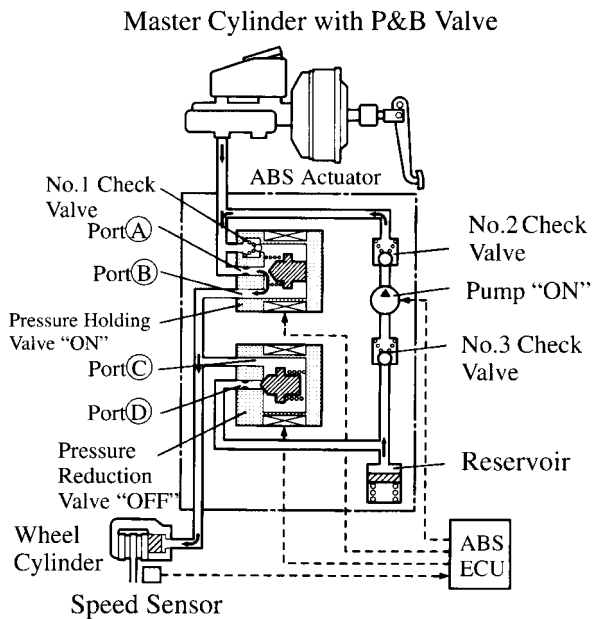

### 3) ABS ECU

#### a. Wheel Speed Control

The ECU constantly receives signals from the 4-speed sensors and a deceleration sensor (2JZ-GTE engine model), and estimates the speed and deceleration rate of the vehicle by calculating the speed and deceleration rate of each wheel.

#### b. Initial Check

An initial check is carried out every time once after the engine has started and the initial vehicle speed exceeds 6 km/h (4 mph).

#### c. Self-Diagnosis

If the ABS ECU detects a malfunction in the ABS, the ABS warning light and a master warning lights in the combination meter will light up and alert the driver that a malfunction has occurred. The ECU will also store the codes of the malfunctions.

## ■ SUSPENSION

### 1. General

- The shock absorber of the 2JZ-GTE engine model with manual transmission has been changed from the mono-tube, gas-filled shock absorber to the twin-tube, gas-filled shock absorber, which is the same type that is used on the 2JZ-GE engine model.
- The same rubber-integrated ball bushing that is used on the 2JZ-GTE engine model is used for the upper arm bushing of the rear suspension of the 2JZ-GE engine model.
- The brace rod of the rear subframe has been relocated to realize excellent riding comfort, in addition, this provides excellent stability, an controllability.