







---

# CLUTCH

**PREPARATION****SST (SPECIAL SERVICE TOOLS)**

	09023-00100	Union Nut Wrench 10 mm	Clutch line
	09301-00110	Clutch Guide Tool	
	09303-35011	Input Shaft Front Bearing Puller	
	09304-30012	Input Shaft Front Bearing Replacer	2JZ-GE Only
	09333-00013	Clutch Diaphragm Spring Aligner	

**RECOMMENDED TOOLS**

	09082-00050	TOYOTA Electrical Tester Set	
	09905-00012	Snap Ring No. 1 Expander	

**EQUIPMENT**

Calipers	
Dial indicator	
Torque wrench	

# TROUBLESHOOTING

Use the table below to help you find the cause of the problem. The numbers indicate the priority of the likely cause of the problem. Check each part in order. If necessary, replace these parts.

	See page	Parts Name	Trouble
	CL-4	Clutch pedal (freeplay out of adjustment)	
	-	Clutch line (Air in line)	
	CL-6	master cylinder cup (Damaged)	
	CL-8 CL-9	Release cylinder cup (Damaged)	
	-	Engine mounting (loosen)	1
	CL-11 CL-17	Release bearing (Worn, dirty or damaged)	
	CL-11 CL-17	Pilot bearing (Worn or damaged)	
	-	Input shaft bearing (Worn or damaged)	
	CL-11 CL-17	Clutch disc (Out of true)	
	CL-11 CL-17	Clutch disc (Runout is excessive)	2
	CL-11 CL-17	Clutch disc (Lining broken)	
	CL-11 CL-17	Clutch disc (Dirty or burred)	
	CL-11 CL-17	Clutch disc (Oily)	2
	CL-11 CL-17	Clutch disc (Worn out)	2
	CL-11 CL-17	Clutch disc torsion rubber (Damaged)	2
	CL-11 CL-17	Clutch disc (Glazed)	2
	CL-15 CL-21	Clutch disc (Lack of spline grease)	
	CL-11 CL-17	Diaphragm spring (Damaged)	
	CL-15 CL-20	Diaphragm spring (Out of tip alignment)	2
	CL-11 CL-17	Pressure plate (Distortion)	
	-	Flywheel (Distortion)	
Clutch grabs/chatters			1
Clutch pedal spongy			1 2 2
Clutch noisy			1 2 3
Clutch slips	1		2 2
Clutch does not disengage	1	2 3 4	6 5 6 6 6 6 6 6

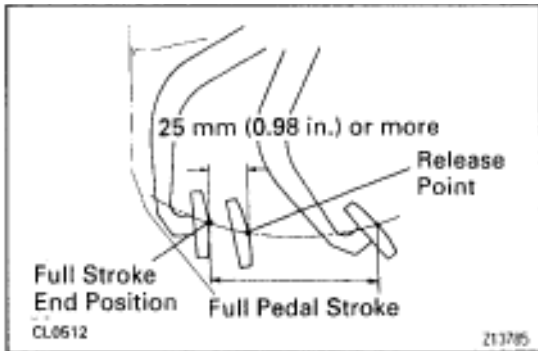
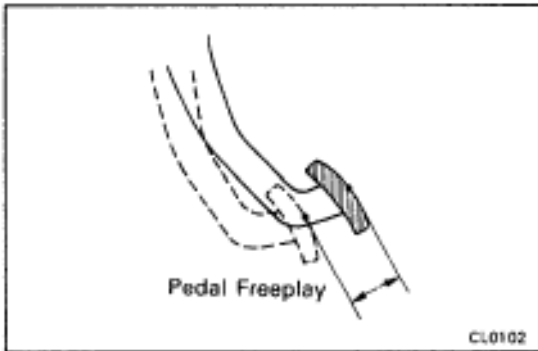
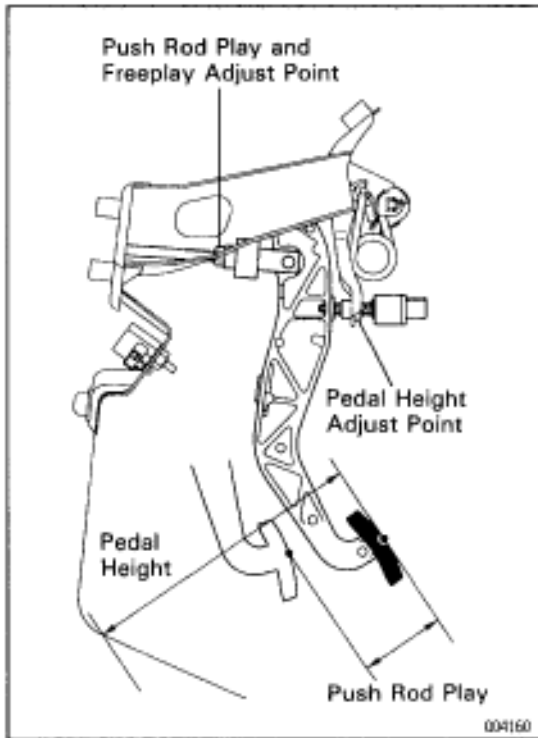

# CLUTCH PEDAL

## CLUTCH PEDAL CHECK AND ADJUSTMENT

### 1. CHECK PEDAL HEIGHT

Pedal height from asphalt sheet:

146.2–156.2 mm (5.76–6.15 in.)

### 2. IF NECESSARY, ADJUST PEDAL HEIGHT

Loosen the lock nut and clutch switch until the height is correct. Tighten the lock nut.

HINT: Before rotating the clutch switch for pedal height adjustment, disconnect the clutch switch connector.

### 3. CHECK PEDAL FREEPLAY AND PUSH ROD PLAY

Push in on the pedal until the beginning of clutch resistance is felt.

**Pedal freeplay: 5.0–15.0 mm (0.197–0.591 in.)**

Gently push on the pedal until the resistance begins to increase a little.

**Push rod play at pedal top:**

1.0–5.0 mm (0.039–0.197 in.)

### 4. IF NECESSARY, ADJUST PEDAL FREEPLAY AND PUSH ROD PLAY

(a) Loosen the lock nut and turn the push rod until the freeplay and push rod play are correct.

(b) Tighten the lock nut.

(c) After adjusting the pedal freeplay, check the pedal height.

### 5. INSPECT FULL PEDAL STROKE

**Full pedal stroke: 132.0–138.0 mm (5.20–5.43 in.)**

### 6. INSPECT CLUTCH RELEASE POINT

(a) Pull the parking brake lever and install wheel stopper.

(b) Start the engine and idle the engine.

(c) Without depressing the clutch pedal, slowly shift the shift lever into position until the gears contact.

(d) Gradually depress the clutch pedal and measure the stroke distance from the point the gear noise stops (release point) up to the full stroke end position.

**Standard distance: 25 mm (0.98 in.) or more**

**(From pedal stroke end position to release point)**

If the distance is not as specified, do the following operation.

- Inspect pedal height.
- Inspect push rod play and pedal freeplay.
- Bleed the clutch line.
- Inspect the clutch cover and disc.

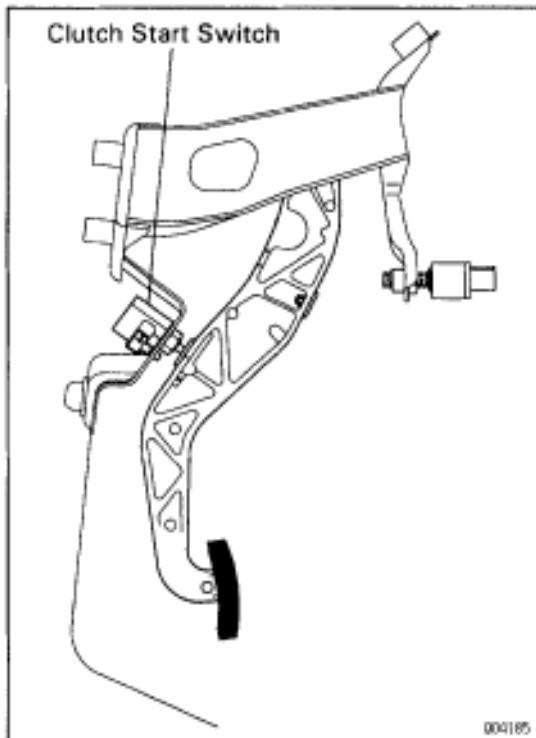

### 7. CHECK CLUTCH START SYSTEM

- (a) Check that the engine does not start when the clutch pedal is released.
- (b) Check that the engine starts when the clutch pedal is fully depressed.

If necessary, adjust or replace the clutch start switch.

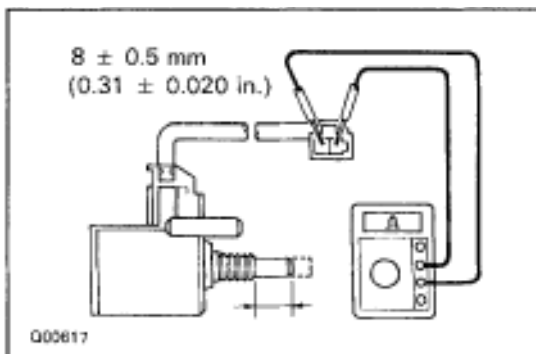

### 8. INSPECT CONTINUITY OF CLUTCH START SWITCH

- (a) Check that there is continuity between terminals when the switch is ON (pushed).
- (b) Check that there is no continuity between terminals when the switch is OFF (free).

If continuity is not as specified, replace the switch.

# CLUTCH MASTER CYLINDER COMPONENTS

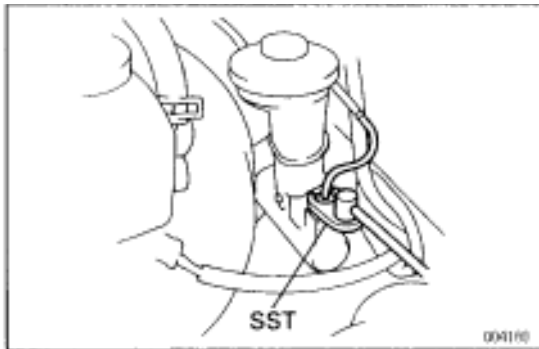
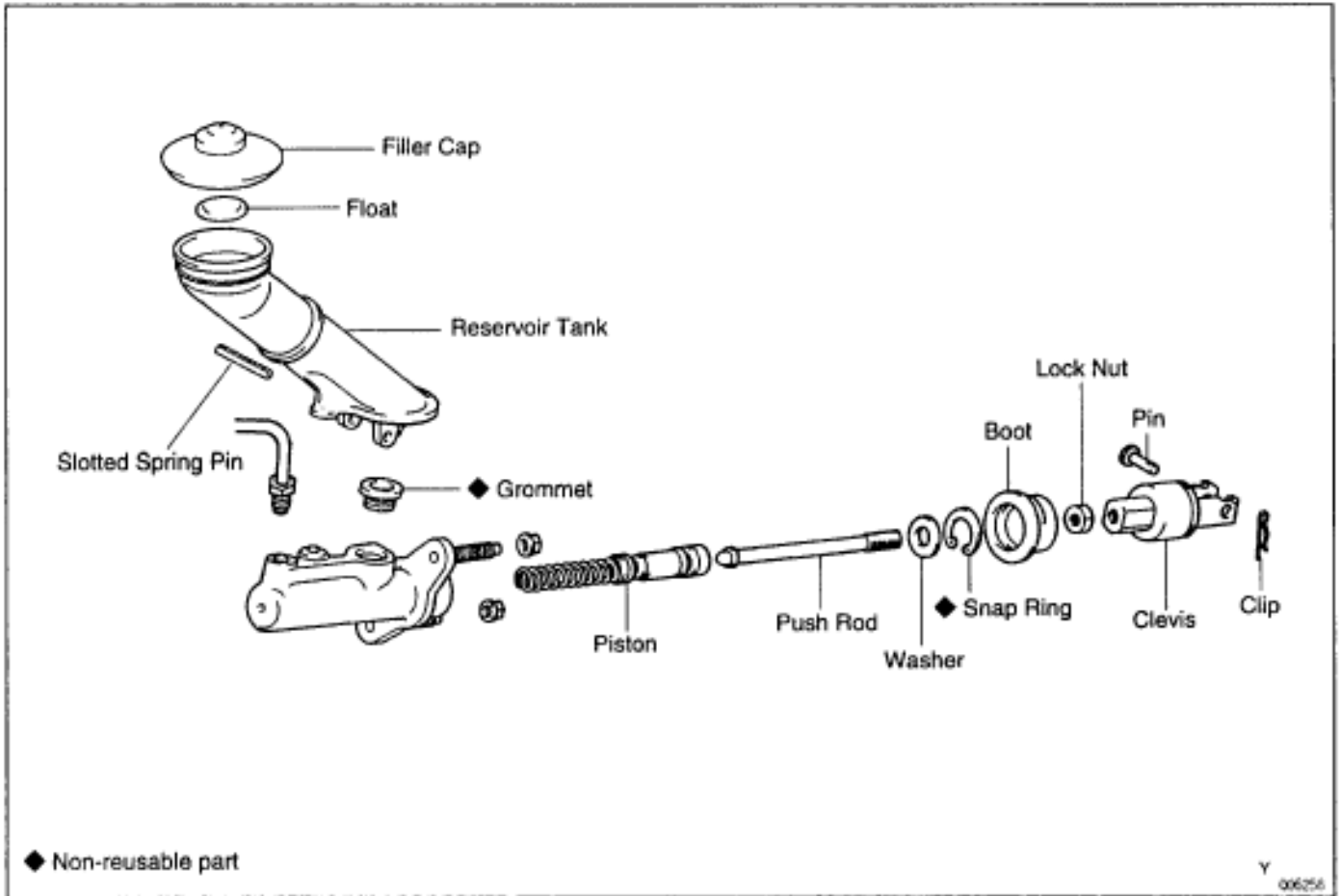

## MASTER CYLINDER REMOVAL

Installation is in the reverse order of removal.

1. **DRAIN OUT FLUID WITH SYRINGE**  
 INSTALLATION HINT: After installation, adjust the clutch pedal and bleed the clutch system.
2. **DISCONNECT CLUTCH LINE UNION**  
 Using SST, disconnect the union nut.  
 SST 09023-00100  
 Torque: 15 N·m (155 kgf·cm, 11 ft·lbf)
3. **REMOVE CLIP AND PIN**
4. **REMOVE 2 MOUNTING NUTS AND PULL OUT MASTER CYLINDER**  
 Torque: 12 N·m (125 kgf·cm, 9 ft·lbf)

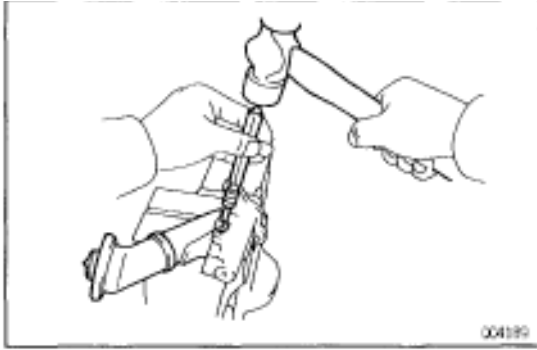

## MASTER CYLINDER DISASSEMBLY

### 1. REMOVE RESERVOIR TANK

- (a) Using a pin punch and hammer, drive out the slotted spring pin.
- (b) Remove the reservoir tank and grommet.

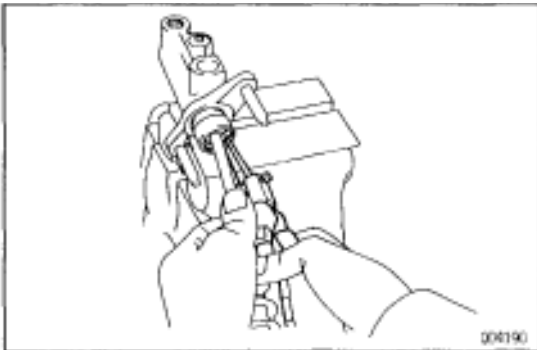

### 2. REMOVE PUSH ROD

- (a) Pull back the boot, and using snap ring pliers, remove the snap ring.
- (b) Pull out the push rod.

### 3. REMOVE PISTON

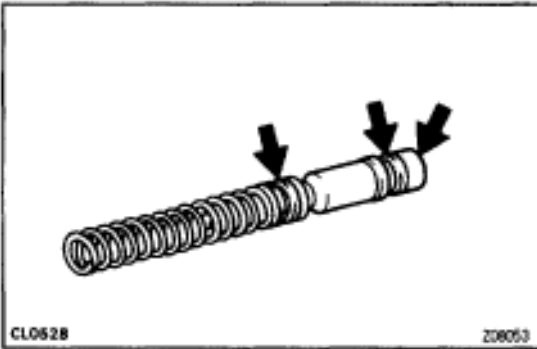

## MASTER CYLINDER ASSEMBLY

1. COAT PARTS WITH LITHIUM SOAP BASE GLYCOL GREASE, AS SHOWN
2. INSERT PISTON INTO CYLINDER
3. INSTALL PUSH ROD ASSEMBLY WITH NEW SNAP RING

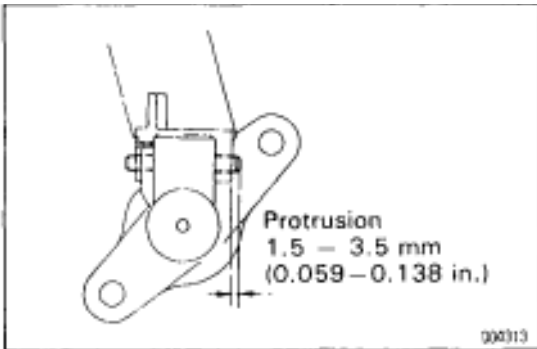

### 4. INSTALL RESERVOIR TANK

- (a) Install the reservoir tank and a new grommet.
- (b) Using a pin punch and hammer, drive in the slotted spring pin.

## CLUTCH RELEASE CYLINDER (2JZ-GTE) COMPONENTS

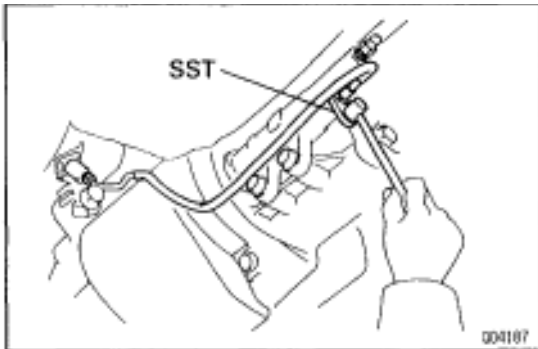
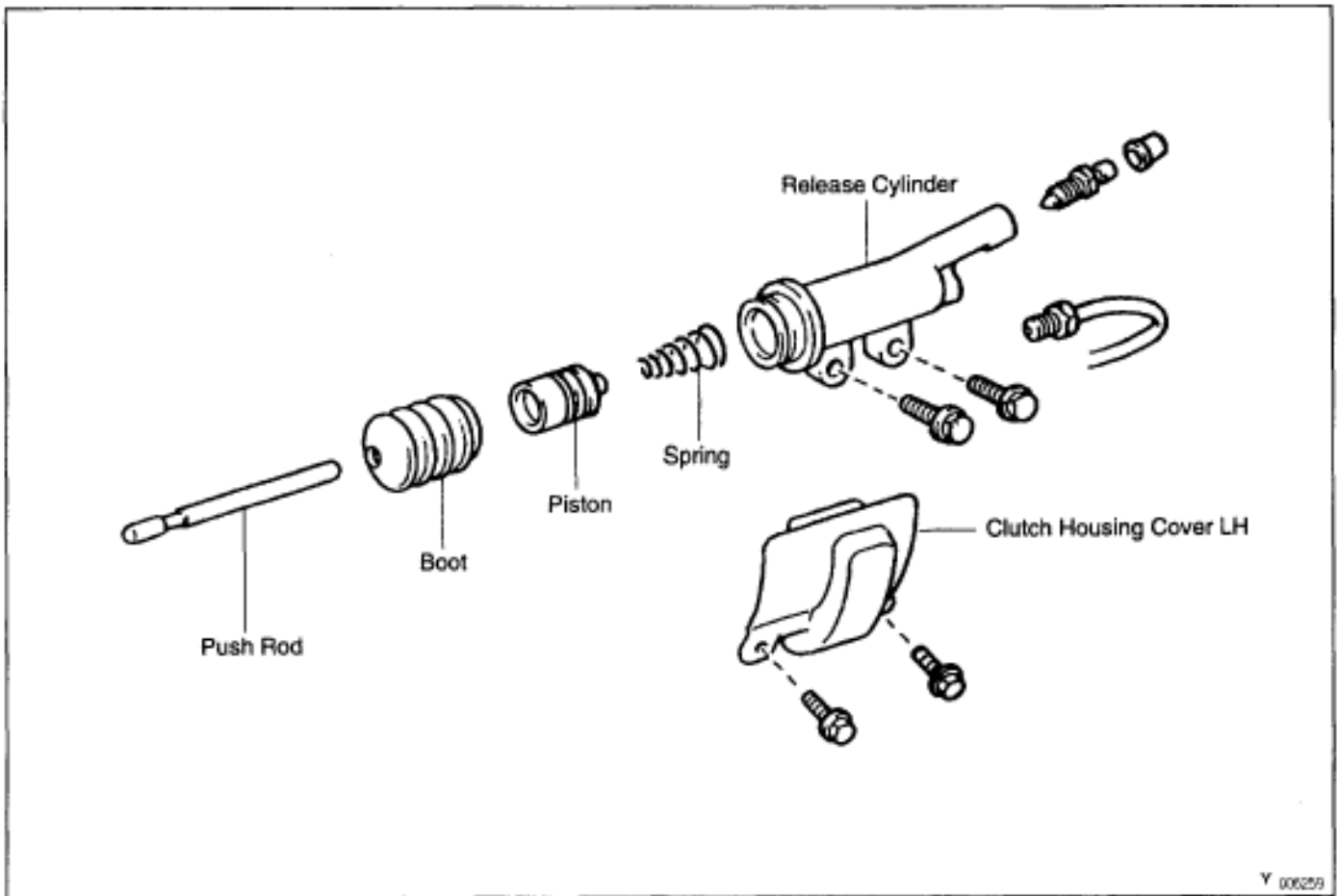

### RELEASE CYLINDER REMOVAL

Installation is in the reverse order of removal.

INSTALLATION HINT: After installation, adjust the clutch pedal and bleed the clutch system.

#### 1. REMOVE CLUTCH HOUSING COVER LH

Remove the 2 bolts.

Torque: 12 N·m (120 kgf·cm, 9 ft·lbf)

#### 2. DISCONNECT CLUTCH LINE

Using SST, disconnect the clutch line union. Use a container to catch the fluid.

SST 09023-00100

Torque: 15 N·m (155 kgf·cm, 11 ft·lbf)

#### 3. REMOVE 2 BOLTS AND PULL OUT RELEASE CYLINDER

Torque: 12 N·m (120 kgf·cm, 9 ft·lbf)



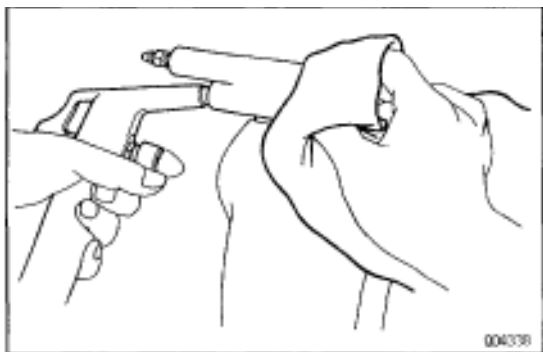

## RELEASE CYLINDER DISASSEMBLY

1. PULL OUT PUSH ROD WITH BOOT
2. REMOVE PISTON WITH SPRING  
Using compressed air, remove the piston and spring from the cylinder.

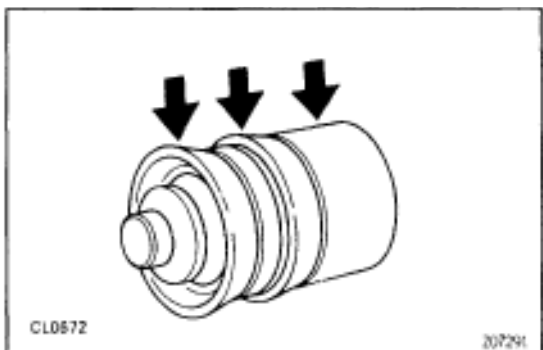

## RELEASE CYLINDER ASSEMBLY

1. COAT PISTON WITH LITHIUM SOAP BASE GLYCOL GREASE, AS SHOWN
2. INSTALL PISTON WITH SPRING INTO CYLINDER
3. INSTALL BOOT WITH PUSH ROD TO CYLINDER

## CLUTCH RELEASE CYLINDER (2JZ-GE) COMPONENTS

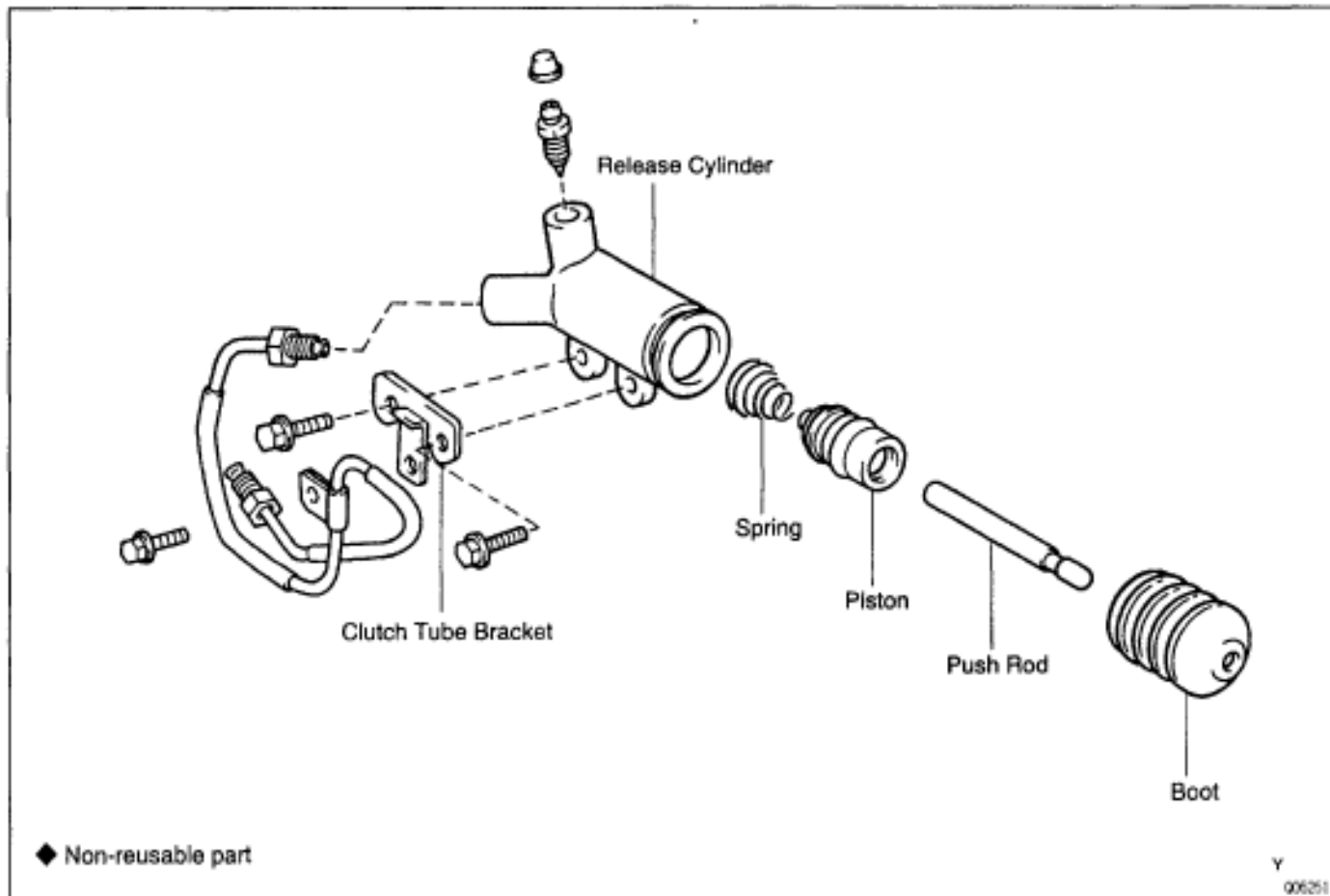

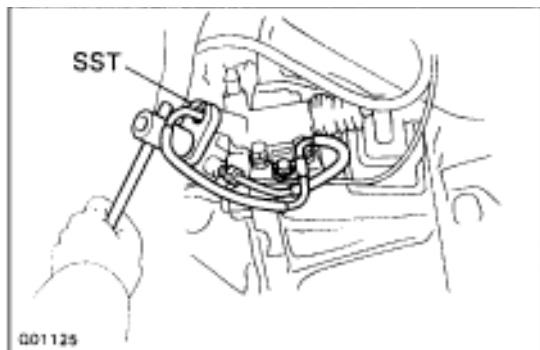

## RELEASE CYLINDER REMOVAL

Installation is in the reverse order of removal.

INSTALLATION HINT: After installation, adjust the clutch pedal and bleed the clutch system.

### 1. DISCONNECT CLUTCH LINE

Using SST, disconnect the clutch line union. Use a container to catch the fluid.

SST 09023-00100

Torque: 15 N·m (155 kgf·cm, 11 ft·lbf)

### 2. REMOVE RELEASE CYLINDER WITH 3 BOLTS

Torque:

A: 12 N·m (120 kgf·cm, 9 ft·lbf)

B: 4.9 N·m (50 kgf·cm, 43 in·lbf)

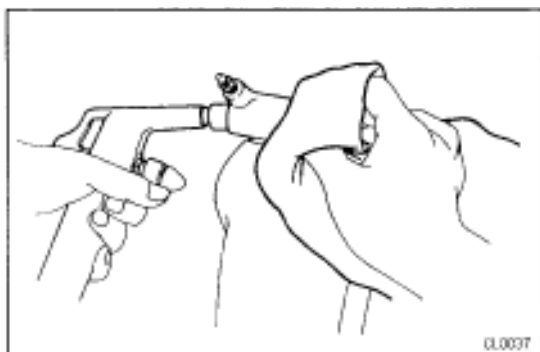
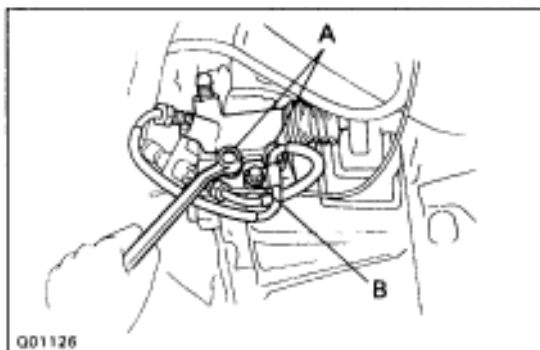

## RELEASE CYLINDER DISASSEMBLY

### 1. PULL OUT PUSH ROD WITH BOOT

### 2. REMOVE PISTON WITH SPRING

Using compressed air, remove the piston and spring from the cylinder.

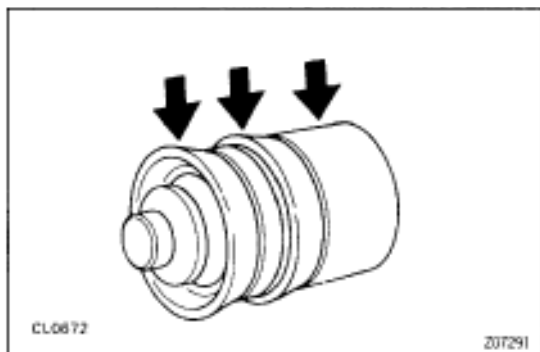

## RELEASE CYLINDER ASSEMBLY

### 1. COAT PISTON WITH LITHIUM SOAP BASE GLYCOL GREASE, AS SHOWN

### 2. INSTALL PISTON WITH SPRING INTO CYLINDER

### 3. INSTALL BOOT WITH PUSH ROD TO CYLINDER

## CLUTCH UNIT (2JZ-GTE) COMPONENTS

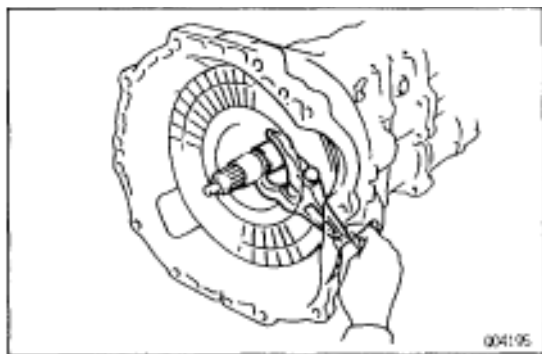
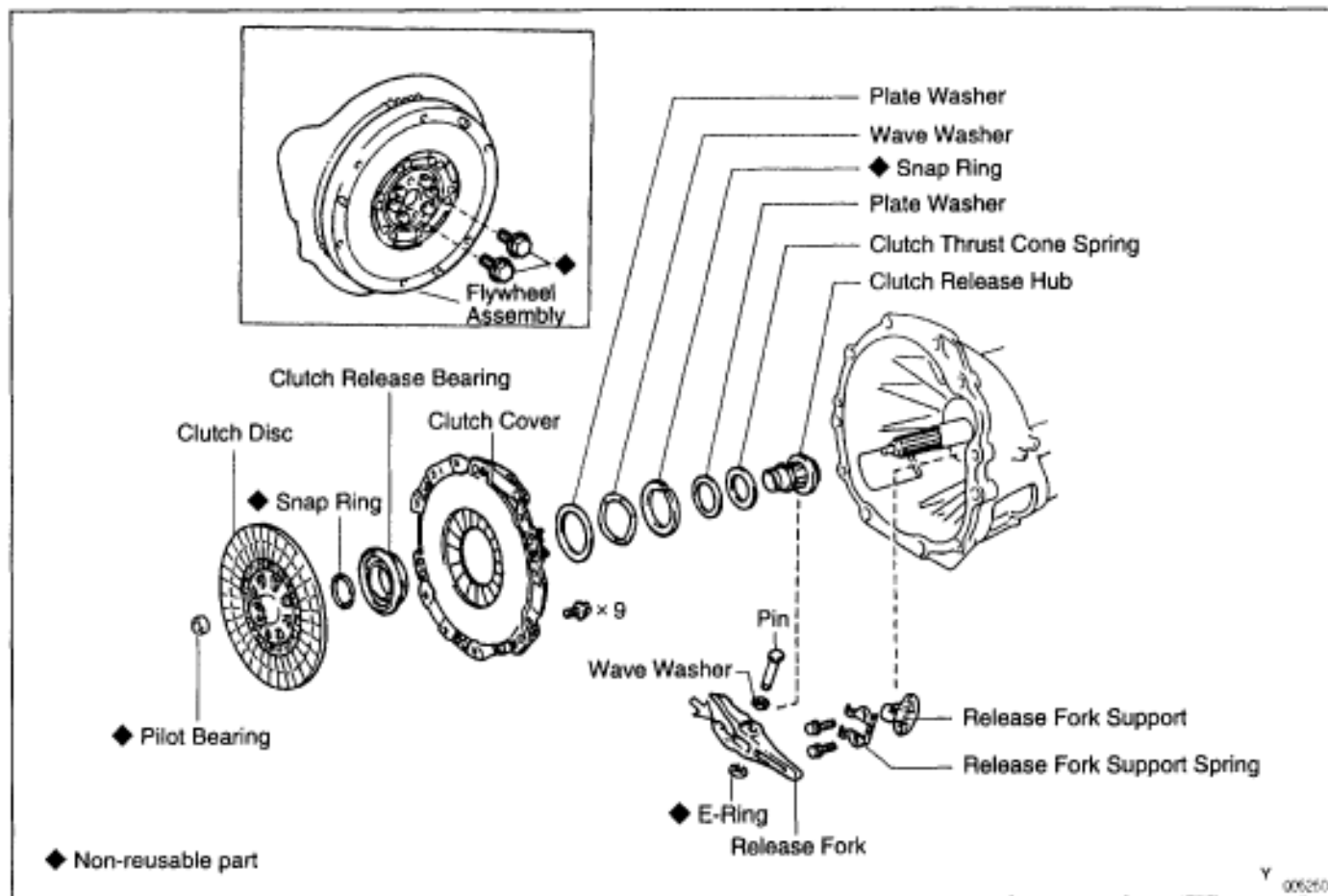

### CLUTCH UNIT REMOVAL

#### 1. REMOVE TRANSMISSION FROM ENGINE (See page [MT2-5](#))

HINT: Do not drain the transmission oil.

#### 2. REMOVE RELEASE FORK ASSEMBLY

(a) Remove the release fork assembly from the left side of clutch housing service hole.

(b) Remove the E-ring from the release fork.

(c) Remove the pin and wave washer from the release fork.

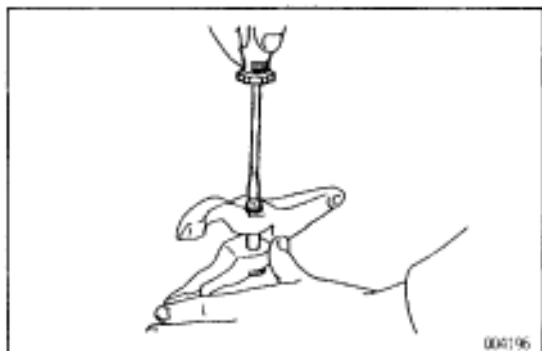

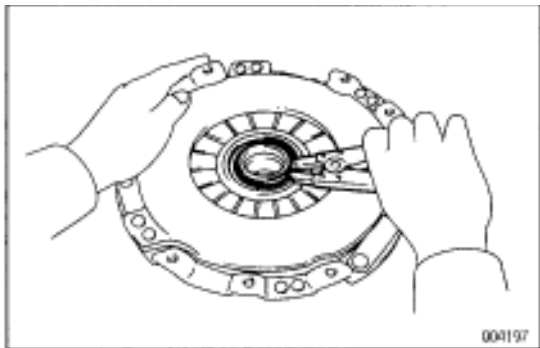

3. **REMOVE CLUTCH DISC**
4. **REMOVE CLUTCH COVER ASSEMBLY**
5. **REMOVE CLUTCH RELEASE BEARING HUB**
  - (a) Using a snap ring expander, remove the snap ring.
  - (b) Remove the release bearing hub, thrust cone spring and plate washer.

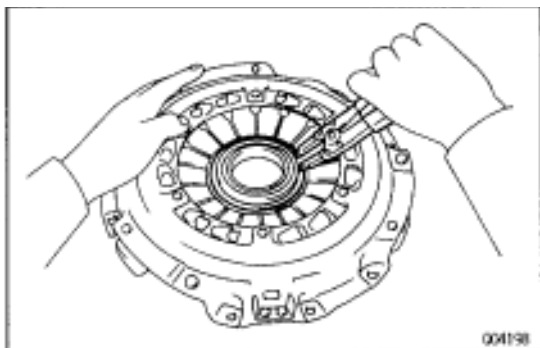

6. **REMOVE CLUTCH RELEASE BEARING**
  - (a) Using a snap ring expander, remove the snap ring.
  - (b) Remove the release bearing, wave washer and plate washer.

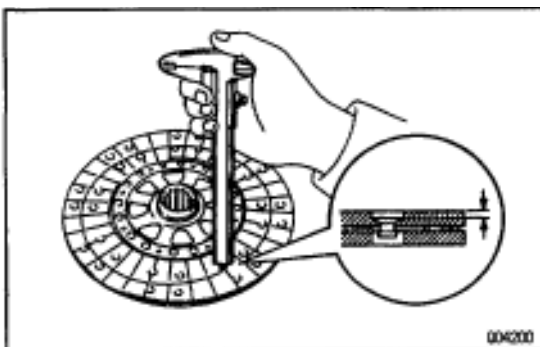

## CLUTCH PARTS INSPECTION AND REPAIR

1. **INSPECT CLUTCH DISC FOR WEAR OR DAMAGE**  
Using calipers, measure the rivet head depth.  
**Minimum rivet depth:**  
**0.3 mm (0.012 in.)**  
If a problem is found, replace the clutch disc.

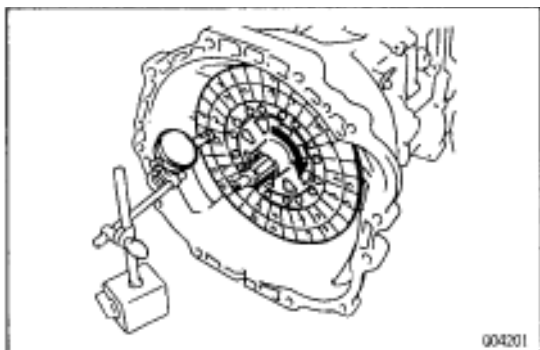

2. **INSPECT CLUTCH DISC RUNOUT**  
Using a dial indicator, check the disc runout.  
**Maximum runout:**  
**0.8 mm (0.031 in.)**  
If runout is excessive, replace the clutch disc.

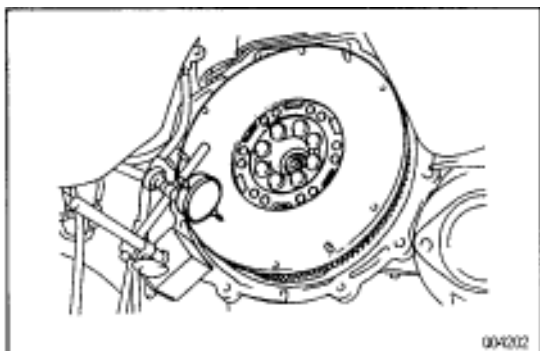

3. **INSPECT FLYWHEEL RUNOUT**  
Using a dial indicator, check the flywheel runout.  
**Maximum runout:**  
**0.1 mm (0.004 in.)**  
If runout excessive, replace the flywheel.

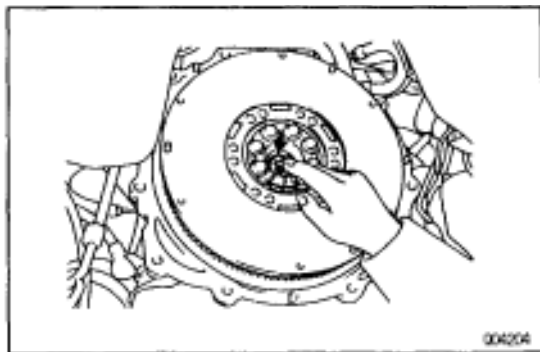

#### 4. INSPECT PILOT BEARING

Turn the bearing by hand while applying force in the axial direction.

If the bearing sticks or has much resistance, replace the pilot bearing.

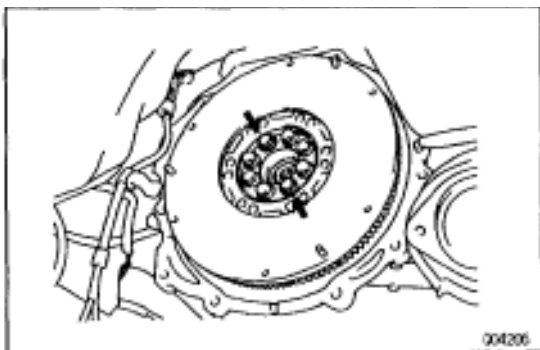

#### 5. IF NECESSARY, REPLACE PILOT BEARING

(a) Remove the 2 bolts at diametrically opposite points.

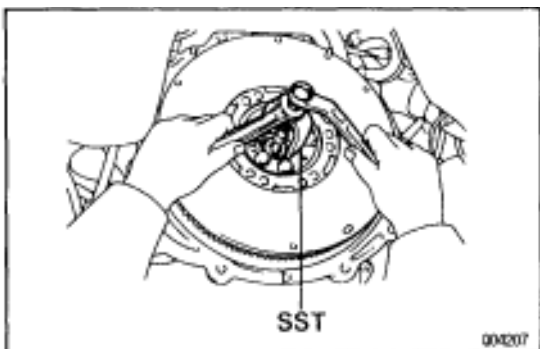

(b) Using SST, remove the pilot bearing.  
SST 09303-35011

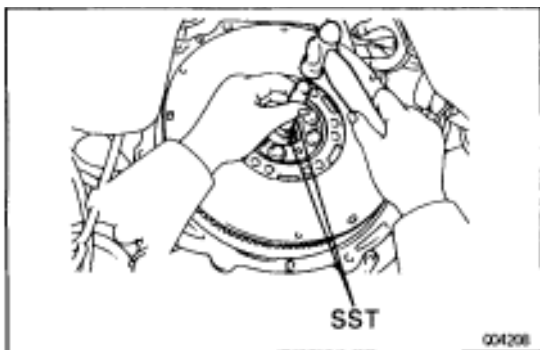

(c) Using SST and a hammer, drive in a new pilot bearing.  
SST 09301-00110

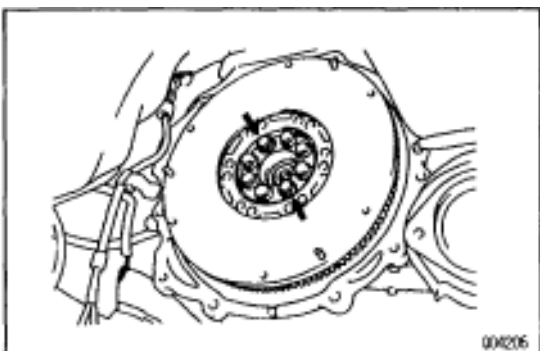

(d) Install 2 new bolts.

(e) First, torque the 2 bolts uniformly a little at a time.

**Torque: 49 N·m (500 kgf·cm, 36 ft·lbf)**

(f) Then tighten the 2 bolts an additional 80-100°.

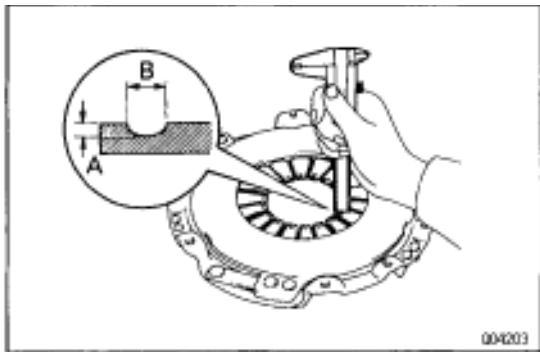

## 6. INSPECT DIAPHRAGM SPRING FOR WEAR

Using calipers, measure the diaphragm spring for depth and width of wear.

**Maximum:**

**A: Depth 0.6 mm (0.024 in.)**

**B: Width 5.0 mm (0.197 in.)**

If necessary, replace the clutch cover.

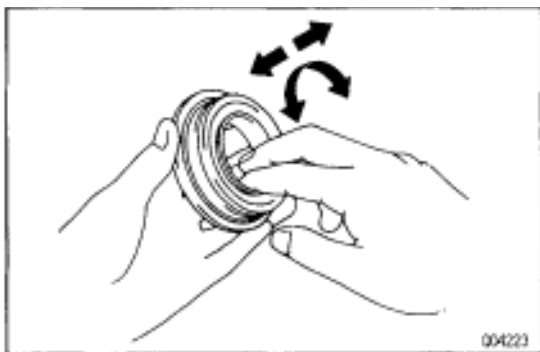

## 7. INSPECT RELEASE BEARING

Turn the bearing by hand while applying force in the axial direction.

**HINT:** The bearing is permanently lubricated and requires no cleaning or lubrication.

If a problem is found, replace the bearing together with the hub.

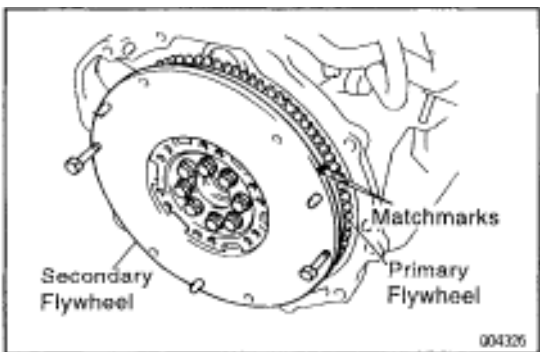

## 8. INSPECT FLYWHEEL DAMPER FOR GREASE LEAKAGE

If grease has sprayed onto the clutch housing, replace the flywheel assembly.

## 9. INSPECT FLYWHEEL DAMPER ROTATIONAL FREEPLAY

(a) Install the 2 bolts to the secondary flywheel at diametrically opposite positions.

(b) Holding both the bolts, turn the secondary flywheel clockwise until it stops.

(c) Put matchmarks on the primary and secondary flywheels at this position.

(d) Then rotate the primary flywheel counterclockwise by hand until it stops.

(e) Put matchmarks on the primary flywheel at this position.

(f) Measure the circumferential length between the 2 matchmarks on the secondary flywheel.

**Standard:**

**105 mm (4.134 in.)**

(g) Repeat the preceding steps (d) to (f) 4 times and if the measurement is greater than the maximum length replace the flywheel assembly.

(See page [EG-122](#))

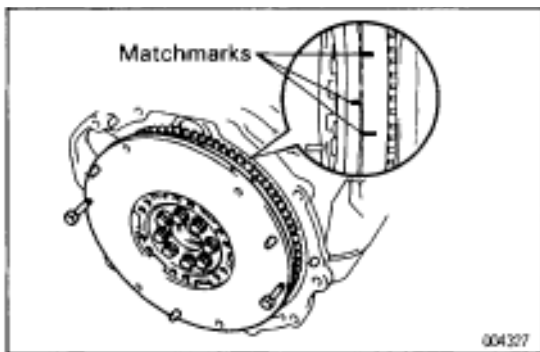

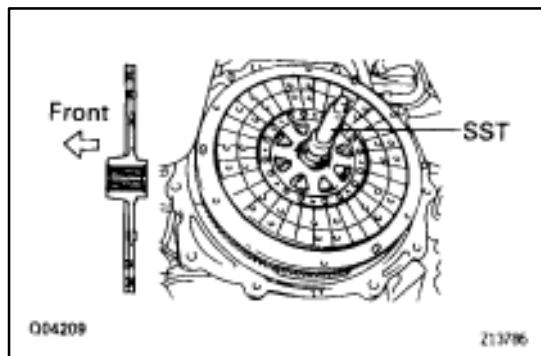

## CLUTCH UNIT INSTALLATION

### 1. INSTALL CLUTCH DISC AND COVER ON FLY-WHEEL

- (a) Insert SST in the clutch disc, and then set them and the cover in position.

SST 09301-00110

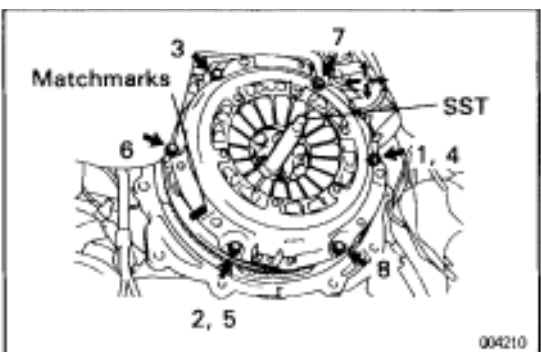

- (b) Align the matchmarks on the clutch cover and fly-wheel.  
 (c) Tighten the bolts evenly and gradually while pushing the SST.  
 Make several passes around the cover until it is snug.

- (d) Torque the bolts on the clutch cover in the order shown.

**Torque: 19 N·m (195 kgf·cm, 14 ft·lbf)**

**HINT:** Temporarily tighten the No.1 and No.2 bolts.

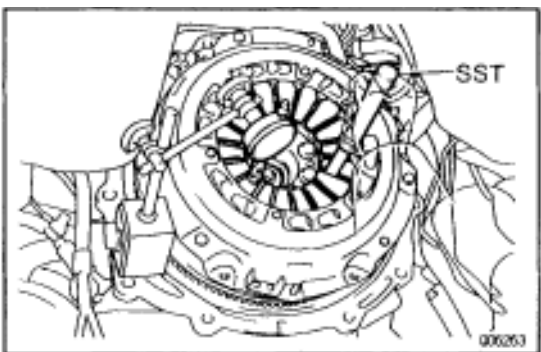

### 2. CHECK DIAPHRAGM SPRING TIP ALIGNMENT

Using a dial indicator with roller instrument, check the diaphragm spring tip alignment.

**Maximum non-alignment:**

**0.5 mm (0.020 in.)**

If alignment is not as specified, use the SST to adjust the diaphragm spring tip alignment.

SST 09333-00013

### 3. REMOVE CLUTCH COVER AND CLUTCH DISC

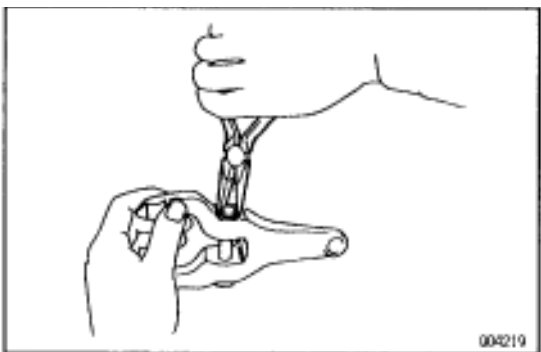

### 4. INSTALL CLUTCH RELEASE FORK

- (a) Install the wave washer and pin to release fork.  
 (b) Install a new E-ring.

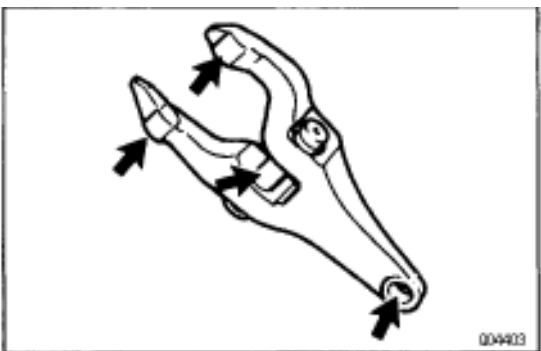

### 5. APPLY MOLYBDENUM DISULPHIDE LITHIUM BASE GREASE (NLGI NO.2)

- (a) Apply release hub grease to these parts:
- Release fork and hub contact point
  - Release fork and push rod contact point
  - Release fork pivot point

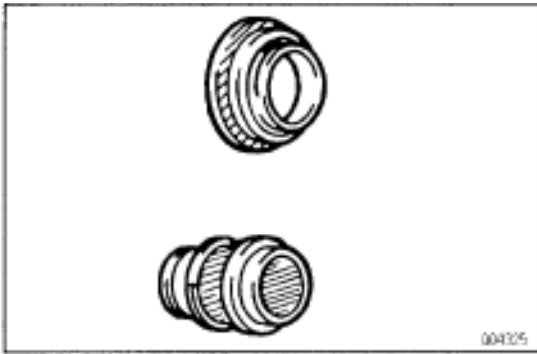

- Release bearing hub inside groove
- Release bearing front surface

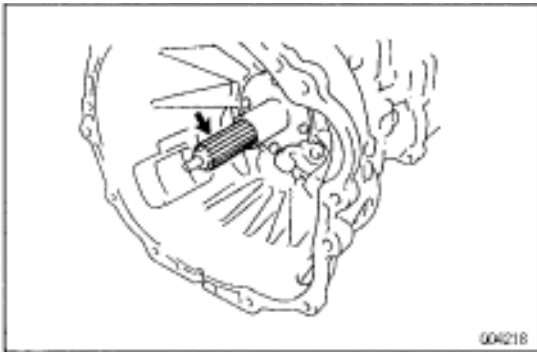

(b) Apply clutch spline grease.

- Clutch disc spline

HINT: Recommended grease part number 08887-01706.

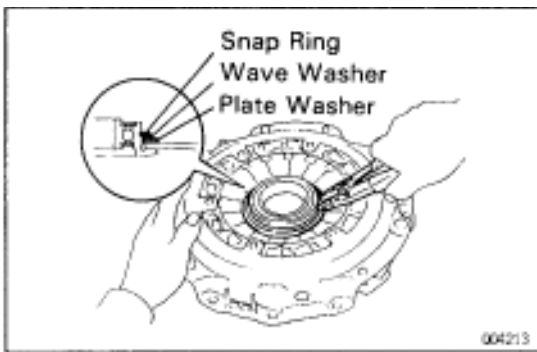

## 6. INSTALL CLUTCH RELEASE BEARING

- (a) Install the release bearing hub, wave washer and plate washer.
- (b) Using a snap ring expander, install a new snap ring.

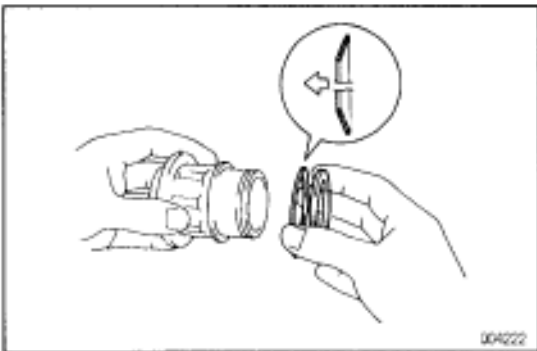

## 7. INSTALL CLUTCH RELEASE BEARING HUB

- (a) Install the thrust cone washer and plate washer to release bearing hub.

**NOTICE:** Install the thrust cone washer in correct direction.

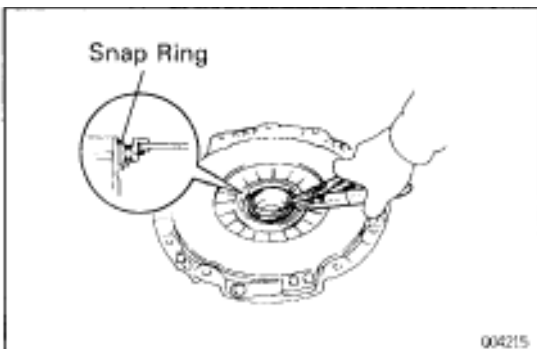

- (b) Install the release bearing hub to release bearing.
- (c) Using a snap ring expander, install a new snap ring.

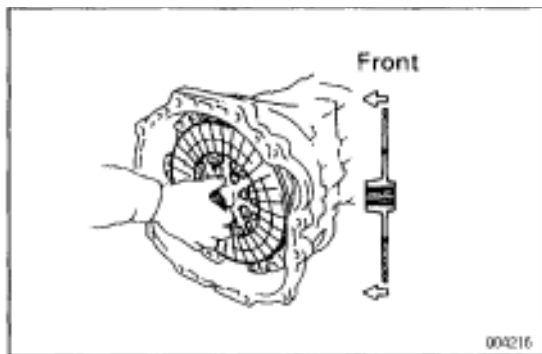

**8. INSTALL CLUTCH COVER ASSEMBLY****9. INSTALL CLUTCH DISC**

**NOTICE:** Install the clutch disc in the correct direction.

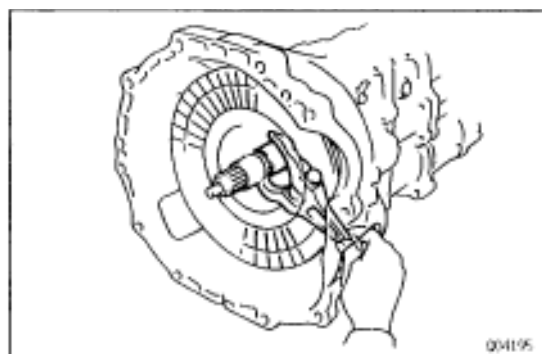
**10. INSTALL RELEASE FORK ASSEMBLY**

Install the release bearing assembly to the release fork assembly, and then install them to the transmission.

**11. INSTALL TRANSMISSION TO ENGINE**

(See page [MT2-5](#))

## CLUTCH UNIT (2JZ-GE) COMPONENTS

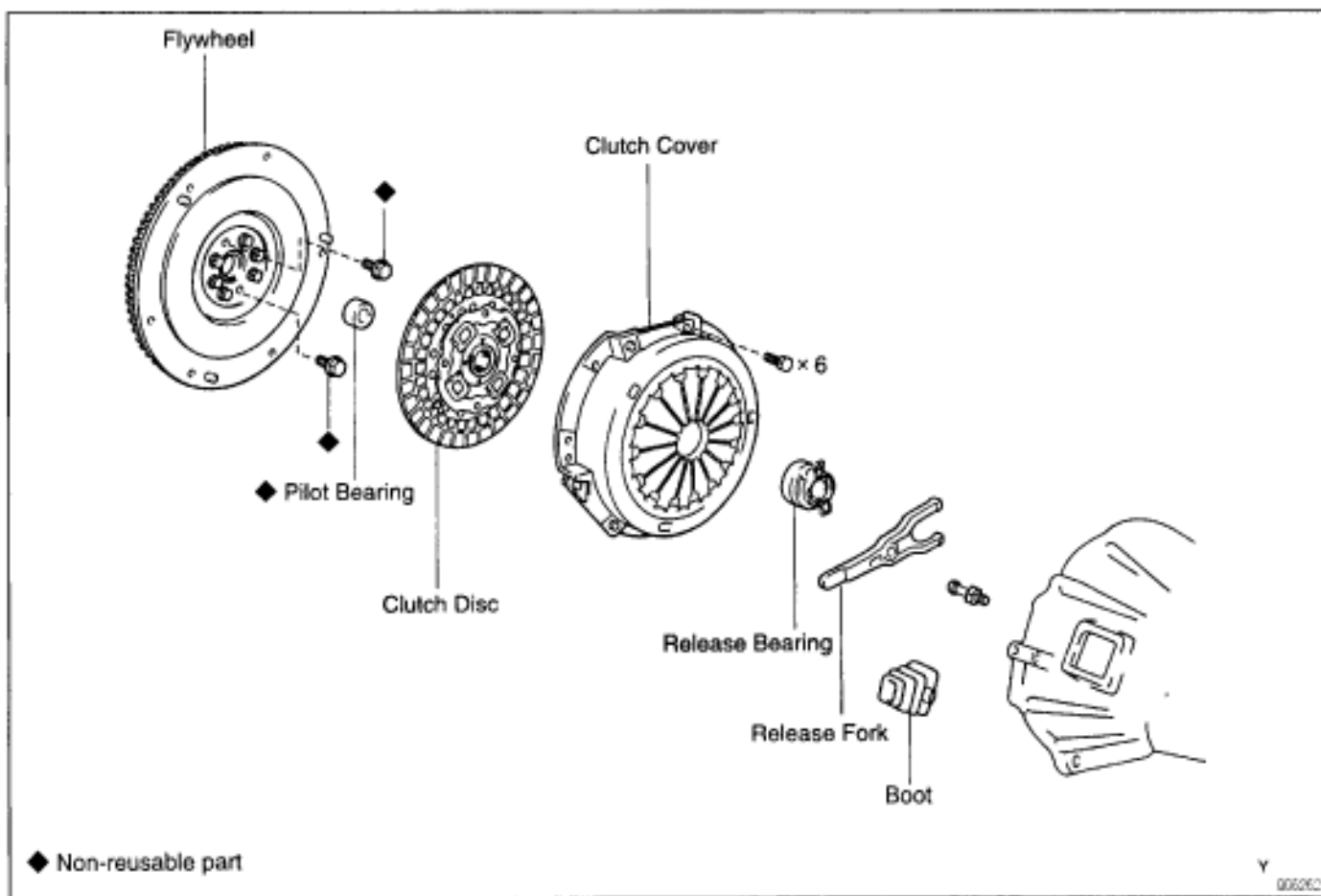

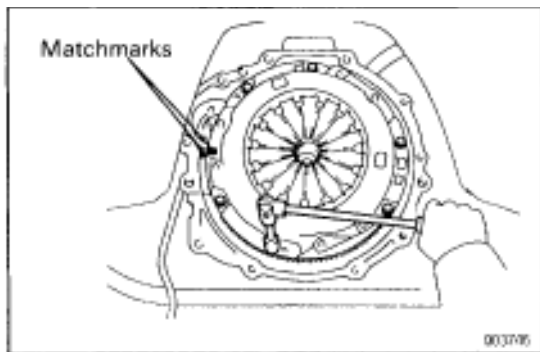

## CLUTCH UNIT REMOVAL

### 1. REMOVE TRANSMISSION FROM ENGINE

(See page [MT1-8](#))

HINT: Do not drain the transmission oil.

### 2. REMOVE CLUTCH COVER AND DISC

- Place matchmarks on the flywheel and clutch cover.
- Loosen each set bolt one turn at a time until spring tension is released.

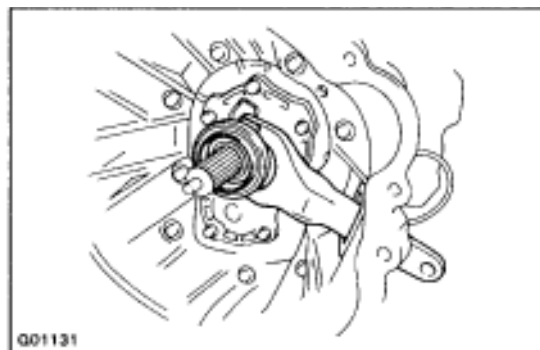

- Remove the set bolts, and pull off the clutch cover with the clutch disc.

**NOTICE:** Do not drop the clutch disc.

### 3. REMOVE RELEASE BEARING, FORK AND BOOT FROM TRANSMISSION

- Remove the clips, and pull off the bearing and hub.
- Remove the fork and boot.

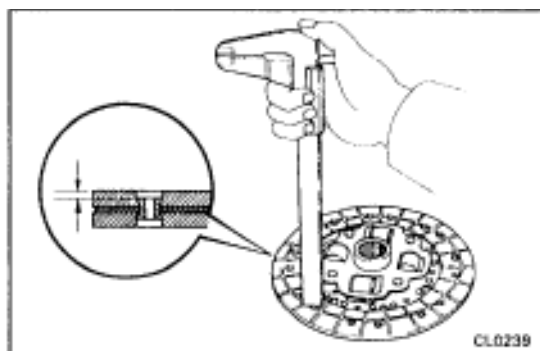

## CLUTCH PARTS INSPECTION AND REPAIR

### 1. INSPECT CLUTCH DISC FOR WEAR OR DAMAGE

Using calipers, measure the rivet head depth.

**Minimum rivet depth:**

**0.3 mm (0.012 in.)**

If a problem is found, replace the clutch disc.

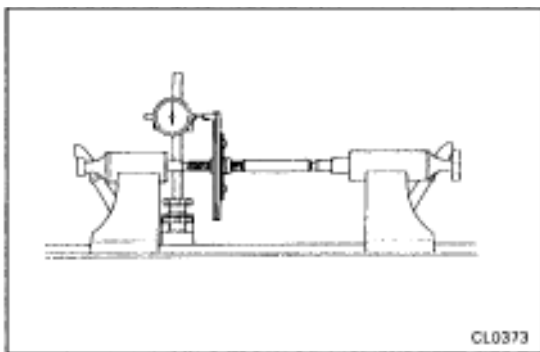

### 2. INSPECT CLUTCH DISC RUNOUT

Using a dial indicator, check the disc runout.

**Maximum runout:**

**0.8 mm (0.031 in.)**

If runout is excessive, replace the clutch disc.

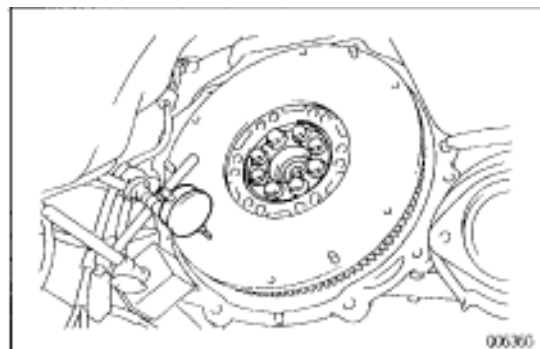

### 3. INSPECT FLYWHEEL RUNOUT

Using a dial indicator, check the flywheel runout.

**Maximum runout:**

**0.1 mm (0.004 in.)**

If runout excessive, replace the flywheel.

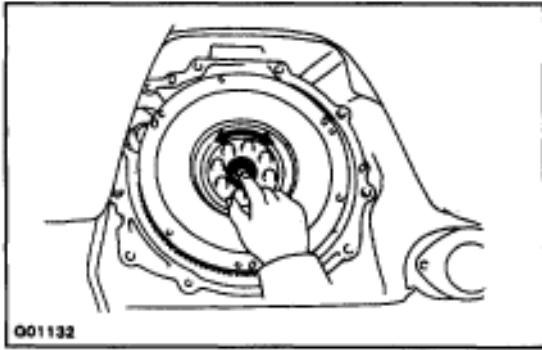

#### 4. INSPECT PILOT BEARING

Turn the bearing by hand while applying force in the axial direction.

If the bearing sticks or has much resistance, replace the pilot bearing.

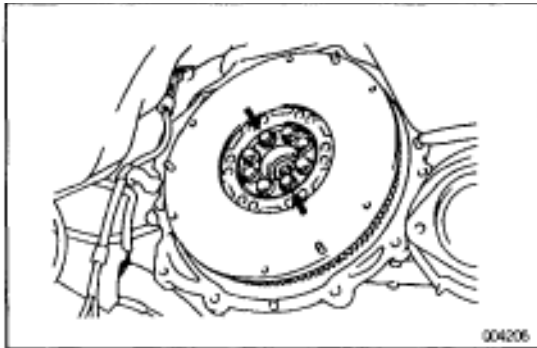

#### 5. IF NECESSARY, REPLACE PILOT BEARING

(a) Remove the 2 bolts at diametrically opposite points.

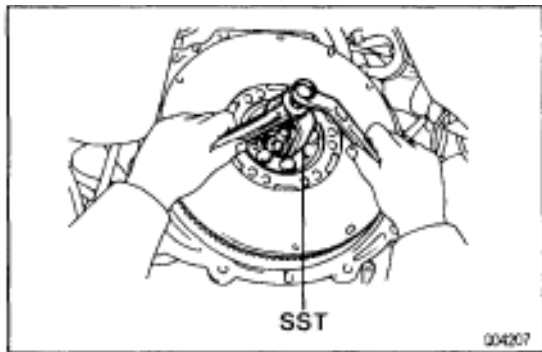

(b) Using SST, remove the pilot bearing.  
SST 09303-35011

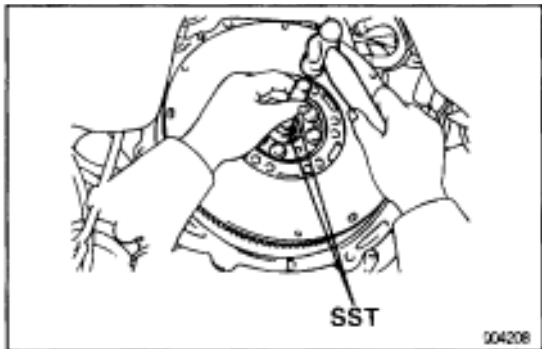

(c) Using SST and a hammer, drive in a new pilot bearing.  
SST 09304-30012

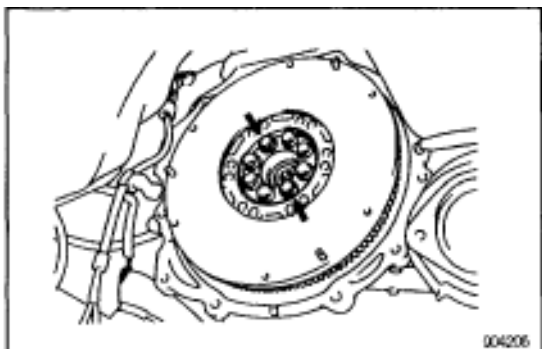

(d) Install 2 new bolts.

(e) First, torque the 2 bolts uniformly a little at a time.

**Torque: 49 N·m (500 kgf·cm, 36 ft·lbf)**

(f) Then tighten the 2 bolts an additional 80-100°.

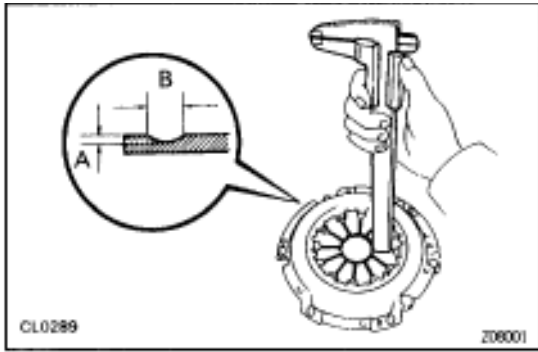

## 6. INSPECT DIAPHRAGM SPRING FOR WEAR

Using calipers, measure the diaphragm spring for depth and width of wear.

**Maximum:**

**A: Depth 0.6 mm (0.024 in.)**

**B: Width 5.0 mm (0.197 in.)**

If necessary, replace the clutch cover.

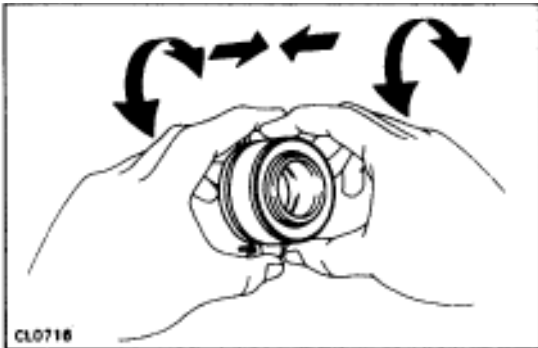

## 7. INSPECT RELEASE BEARING

Turn the bearing by hand while applying force in the axial direction.

**HINT:** The bearing is permanently lubricated and requires no cleaning or lubrication.

If a problem is found, replace the bearing together with the hub.

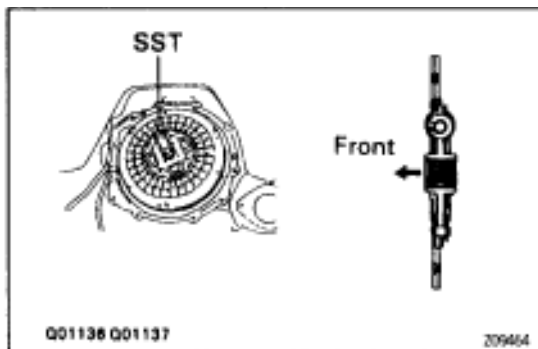

## CLUTCH UNIT INSTALLATION

### 1. INSTALL CLUTCH DISC AND CLUTCH COVER ON FLYWHEEL

- (a) Insert the SST in the clutch disc, and then set them and the cover in position.

SST 09301-00110

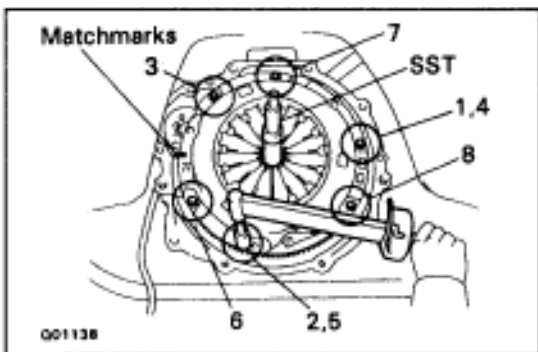

- (b) Align the matchmarks on the clutch cover and fly-wheel.
- (c) Tighten the bolts evenly and gradually while pushing SST. Make several passes around the cover until it is snug.
- (d) Torque the bolts on the clutch cover in order shown.

**Torque: 19 N·m (195 kgf·cm, 14 ft·lbf)**

**HINT:** Temporarily tighten the No.1 and No.2 bolts.

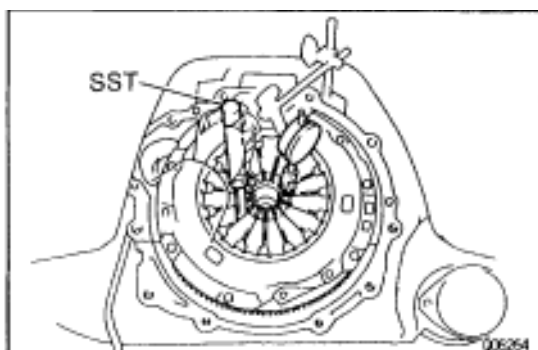

### 2. CHECK DIAPHRAGM SPRING TIP ALIGNMENT

Using a dial indicator with roller instrument, check the diaphragm spring tip alignment.

**Maximum non-alignment:**

**0.5 mm (0.020 in.)**

If alignment is not as specified, using SST adjust the diaphragm spring tip alignment.

SST 09333-00013

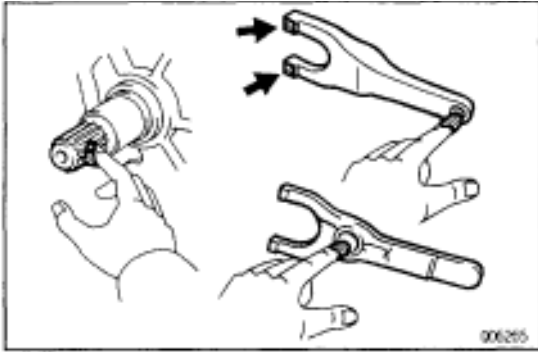

### 3. APPLY MOLYBDENUM DISULPHIDE LITHIUM BASE GREASE (NLGI NO.2)

- (a) Apply release hub grease to these parts:
  - Release fork and hub contact point
  - Release fork and push rod contact point
  - Release fork pivot point
- (b) Apply clutch spline grease.
  - Clutch disc spline

HINT: Recommended grease part number 08887-01706.

### 4. INSTALL RELEASE BEARING, FORK AND BOOT TO TRANSMISSION

- (a) Install the bearing assembly to the fork, and then install them to the transmission.
- (b) Install the boot.

### 5. INSTALL TRANSMISSION TO ENGINE

(See page [MT1-8](#))

# SERVICE SPECIFICATIONS

## SERVICE DATA

Pedal height from asphalt sheet		146.2–156.2 mm (5.76–6.15 in.)
Pedal freeplay		5.0–15.0 mm (0.197–0.591 in.)
Push rod play at pedal top		1.0–5.0 mm (0.039–0.197 in.)
Full pedal stroke		132.0–138.0 mm (5.20–5.43 in.)
Clutch release point from pedal full stroke end position		25 mm (0.98 in.) or more
Disc rivet head depth	Maximum	0.3 mm (0.012 in.)
Disc runout	Maximum	0.8 mm (0.031 in.)
Diaphragm spring out non-alignment	Maximum	0.5 mm (0.020 in.)
Diaphragm spring finger wear	Depth Maximum	0.6 mm (0.024 in.)
Diaphragm spring finger wear	Width Maximum	5.0 mm (0.197 in.)
Flywheel runout	Maximum	0.1 mm (0.004 in.)
Flywheel damper rotational freeplay (2JZ–GTE)	Standard	105 mm (4.134 in.)

## TORQUE SPECIFICATIONS

Part tightened	N·m	kgf·cm	ft·lbf
Clutch cover x Flywheel	19	195	14
Master cylinder set nut	12	125	9
Release cylinder set bolt	12	120	9
Clutch tube bracket (2JZ–GE)	4.9	50	43 in.·lbf
Clutch line union	15	155	11
Bleeder plug	11	110	8
Flywheel set bolt	49	500	36
Release fork support (2JZ–GTE)	25	260	18
Release fork support (2JZ–GE)	39	400	29
Clutch housing cover LH (2JZ–GTE)	12	120	9