

W58 MANUAL TRANSMISSION

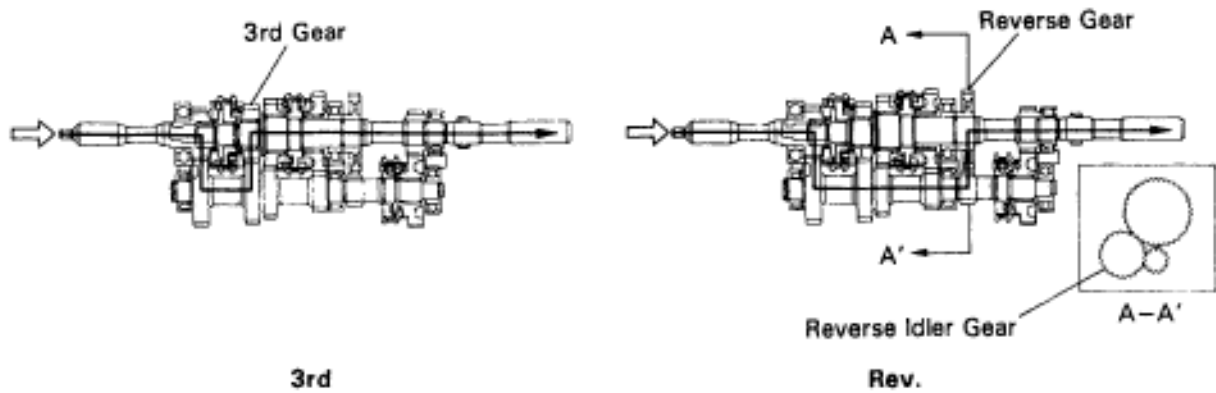

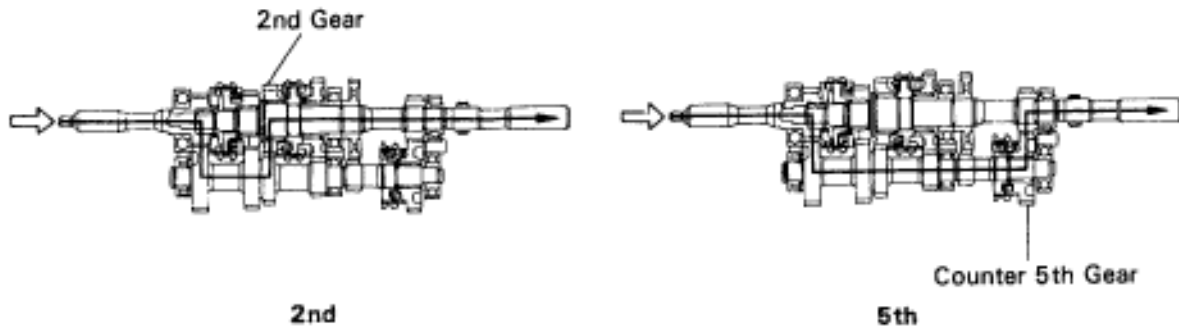

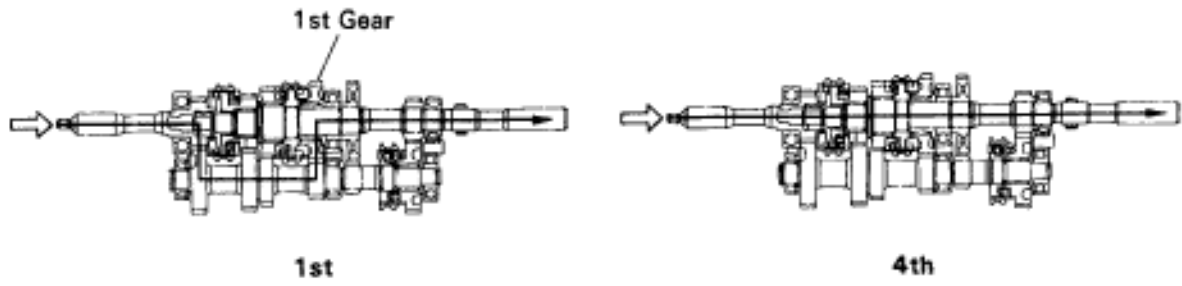





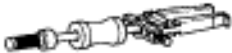

OPERATION













- The illustrations below show the engagements of transmission gears.





PREPARATION

SST (SPECIAL SERVICE TOOLS)

	09304-12012	Input Shaft Front Bearing Replacer	
	09308-00010	Oil Seal Puller	
	09308-10010	Oil Seal Puller	
	09312-20011	Transmission Gear Remover & Replacer	
	(09313-00010)	Reverse Gear Remover	
	(09313-00030)	Rear Bearing Remover	
	(09313-00040)	Plate "A"	
	(09313-00050)	Plate "B"	
	09316-60010	Transmission & Transfer Bearing Replacer	
	(09316-00010)	Replacer Pipe	
	(09316-00070)	Replacer "F"	
	09325-20010	Transmission Oil Plug	
	09506-35010	Differential Drive Pinion Rear Bearing Replacer	Input shaft bearing Output shaft center bearing

	<p>09608-12010 Front Hub & Drive Pinion Bearing Replacer Set</p>	
	<p>(09608-00020) Remover & Replacer Handle</p>	
	<p>(09608-00050) Drive Pinion Front Bearing Cup Replacer</p>	<p>Extension housing outer race</p>
	<p>09608-20012 Front Hub & Drive Pinion Bearing Tool Set</p>	
	<p>(09608-00080) Replacer</p>	<p>Front bearing retainer oil seal</p>
	<p>(09608-03020) Handle</p>	
	<p>09608-35014 Axle Hub & Drive Pinion Bearing Tool Set</p>	
	<p>(09608-06020) Handle</p>	
	<p>(09608-06090) Front Hub Outer & Steering Worm Bearing Replacer</p>	<p>Counter gear bearing outer race</p>
	<p>(09608-06100) Front Hub Outer Bearing Replacer</p>	<p>Extension housing outer race</p>
	<p>09950-00020 Bearing Remover</p>	
	<p>09950-40010 Puller B Set</p>	

RECOMMENDED TOOLS

	09031-00030 Pin Punch ♦	
	09042-00020 Torx Socket T40 ♦	
	09905-00012 Snap Ring No.1 Expand ♦	

EQUIPMENT

Calipers	
Dial indicator	
Micrometer	
Torque wrench	
Feeler gauge	

LUBRICANT

Item	Capacity	Classification
Manual transmission oil	2.6 liters (2.7 US qts, 2.3 Imp. qts)	API GL-3, GL-4 or GL-5 SAE 75W-90

SSM (SPECIAL SERVICE MATERIALS)

08826-00090	Seal Packing 1281, THREE BOND 1281 or equivalent (FIPG)	Transmission case x Intermediate plate Front bearing retainer x Transmission case
08833-00080	Adhesive 1344, THREE BOND 1344, LOCTITE 242 or equivalent	Straight screw plug Front bearing retainer bolt

TROUBLESHOOTING

Use the table below to help you find the cause of the problem. The numbers indicate the priority of the likely cause of the problem. Check each part in order. If necessary, replace these parts.

	Oil (Level low)	Oil (Wrong)	Oil (Level too high)	Gasket (Damaged)	Oil seal (Worn or damaged)	O-Ring (Worn or damaged)	Locking ball spring (Damaged)	Shift fork (Worn)	Gear (Worn or damaged)	Bearing (Worn or damaged)	Synchronizer ring (Worn or damaged)	Shifting key spring (Damaged)
See page	-	MT2-2	-	MT1-11	MT1-11	MT1-11	MT1-11	MT1-12	MT1-12	MT1-12	MT1-24,26 34	MT1-26,34
Parts Name												
Trouble												
Noise	1	2							3	3		
Oil leakage			1	2	2	3						
Hard to shift or will not shift											1	2
Jumps out of gear							1	2	3	3		

PRECAUTION

When working with FIPG material, you must observe the following.

- Using a razor blade and gasket scraper, remove all the old FIPG material from the gasket surfaces.
- Thoroughly clean all components to remove all the loose material.
- Clean both sealing surfaces with a non-residue solvent.
- Apply the FIPG in an approx. 1 mm (0.04 in.) wide bead along the sealing surface.
- Parts must be assembled within 10 minutes of application. Otherwise, the FIPG material must be removed and reapplied.

TROUBLESHOOTING

Use the table below to help you find the cause of the problem. The numbers indicate the priority of the likely cause of the problem. Check each part in order. If necessary, replace these parts.

	Oil (Level low)	Oil (Wrong)	Oil (Level too high)	Gasket (Damaged)	Oil seal (Worn or damaged)	O-Ring (Worn or damaged)	Locking ball spring (Damaged)	Shift fork (Worn)	Gear (Worn or damaged)	Bearing (Worn or damaged)	Synchronizer ring (Worn or damaged)	Shifting key spring (Damaged)
See page	-	MT2-2	-	MT1-11	MT1-11	MT1-11	MT1-11	MT1-12	MT1-12	MT1-12	MT1-24,26 34	MT1-26,34
Parts Name												
Trouble												
Noise	1	2							3	3		
Oil leakage			1	2	2	3						
Hard to shift or will not shift											1	2
Jumps out of gear							1	2	3	3		

PRECAUTION

When working with FIPG material, you must observe the following.

- Using a razor blade and gasket scraper, remove all the old FIPG material from the gasket surfaces.
- Thoroughly clean all components to remove all the loose material.
- Clean both sealing surfaces with a non-residue solvent.
- Apply the FIPG in an approx. 1 mm (0.04 in.) wide bead along the sealing surface.
- Parts must be assembled within 10 minutes of application. Otherwise, the FIPG material must be removed and reapplied.

ASSEMBLY REMOVAL AND INSTALLATION

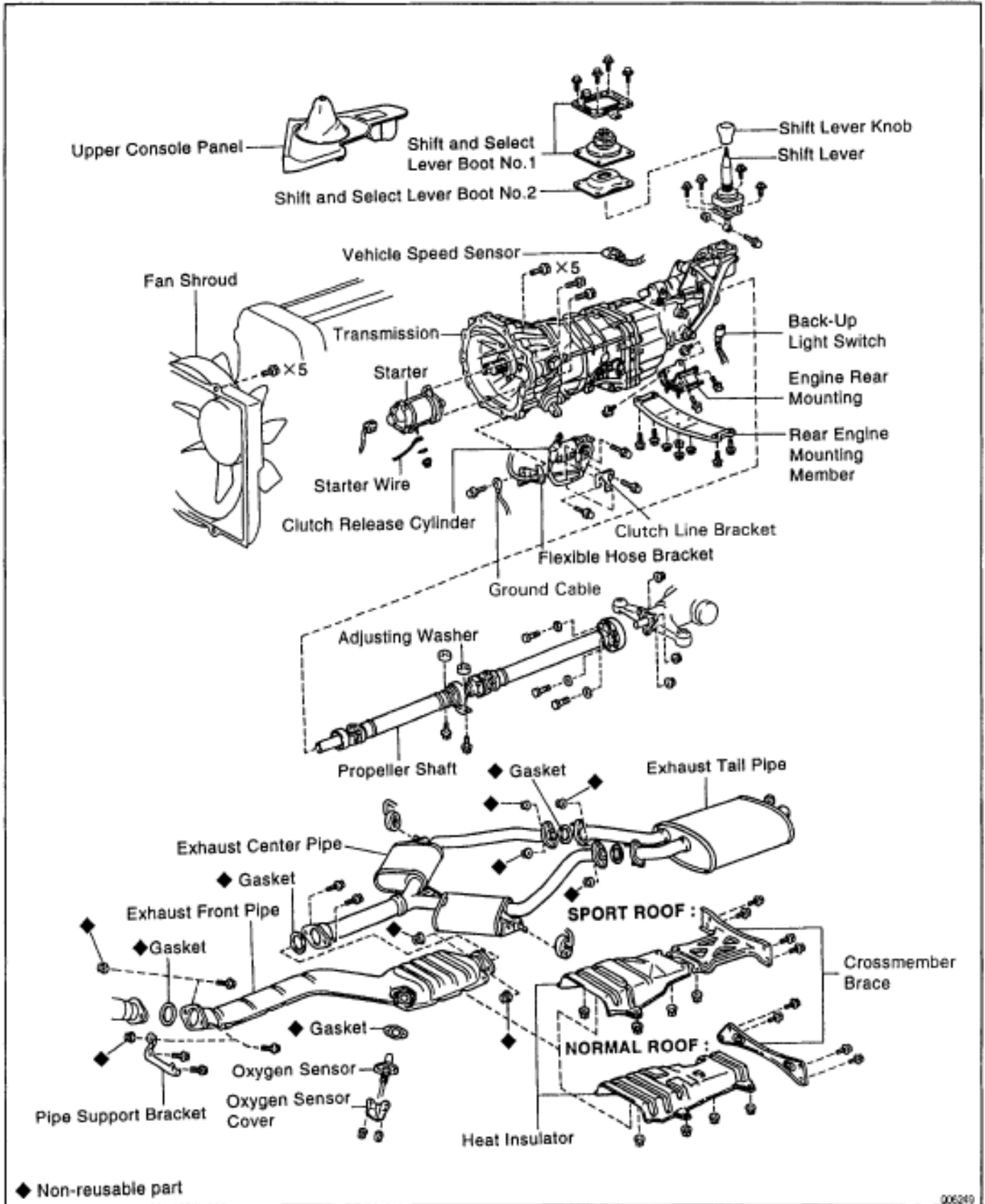

TRANSMISSION REMOVAL

Installation is in the reverse order of removal.

INSTALLATION HINT: After installation, check and inspect item as follows.

- Road test the vehicle.

1. REMOVE FAN SHROUD SET BOLTS

Remove the 5 bolts.

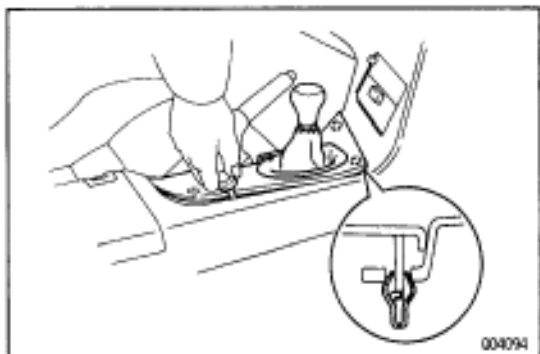

2. REMOVE UPPER CONSOLE PANEL, SHIFT LEVER BOOT AND MOUNTING BOLTS

- Remove the shift lever knob.
- Using a screwdriver, pry out the upper console panel.

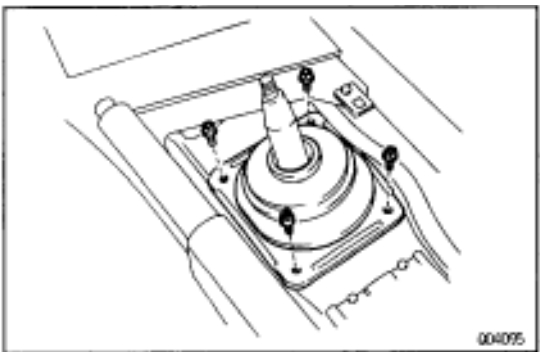

- Remove the 4 mounting bolts.
- Remove the shift and select lever boot No.1 and No.2.

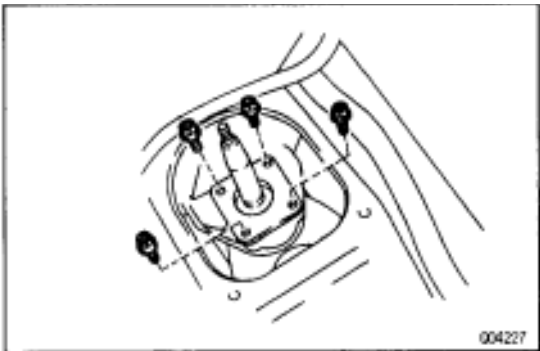

- Remove the 4 mounting bolts.
Torque: 7.8 N·m (80 kgf·cm, 69 in·lbf)

3. RAISE VEHICLE

NOTICE: Be sure the vehicle is securely supported.

4. DRAIN TRANSMISSION OIL

Oil grade:

API GL-3, GL-4 or GL-5

Viscosity:

SAE 75W-90

Capacity:

2.6 liters (2.7 US qts, 2.3 Imp.qts)

5. REMOVE EXHAUST FRONT PIPE AND PIPE SUPPORT BRACKET

- Remove the 2 nuts, cover and oxygen sensor.
Torque: 18 N·m (180 kgf·cm, 13 ft·lbf)

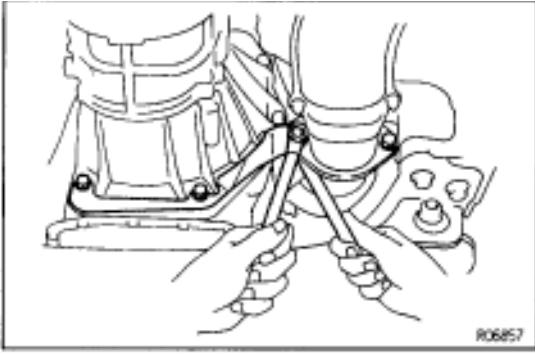

- (b) Remove the 2 bolts and nuts.
Torque: 43 N·m (440 kgf·cm, 32 ft·lbf)
- (c) Remove the 2 bolts and pipe support bracket.
Torque: 37 N·m (380 kgf·cm, 27 ft·lbf)

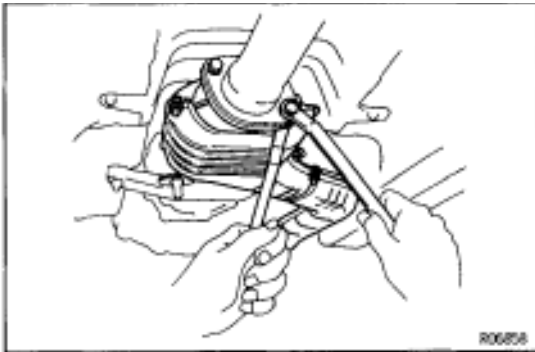

- (d) Remove the 2 bolts and nuts.
Torque: 43 N·m (440 kgf·cm, 32 ft·lbf)
- (e) Remove the exhaust front pipe.

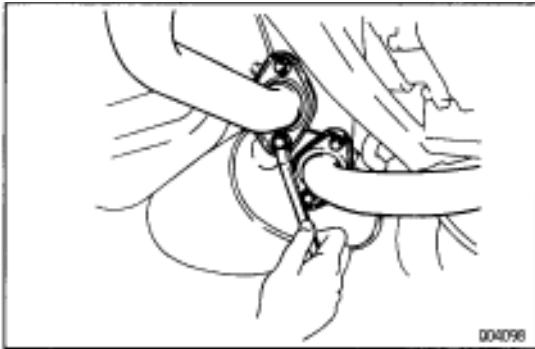

6. REMOVE EXHAUST CENTER PIPE

- (a) Remove the 4 nuts.
Torque: 19 N·m (195 kgf·cm, 14 ft·lbf)
- (b) Disconnect the exhaust center pipe from the 2 rings.
- (c) Remove the exhaust center pipe.

7. REMOVE HEAT INSULATOR

Remove the 4 nuts and heat insulator.

Torque: 5.4 N·m (55 kgf·cm, 48 in·lbf)

8. REMOVE CROSSMEMBER BRACE

Normal Roof:

Remove the 4 bolts and center floor crossmember brace.

Sport Roof:

Remove the 6 bolts and center floor crossmember brace.

Torque: 13 N·m (130 kgf·cm, 9 ft·lbf)

9. REMOVE PROPELLER SHAFT

(See page [PR-7](#), 13)

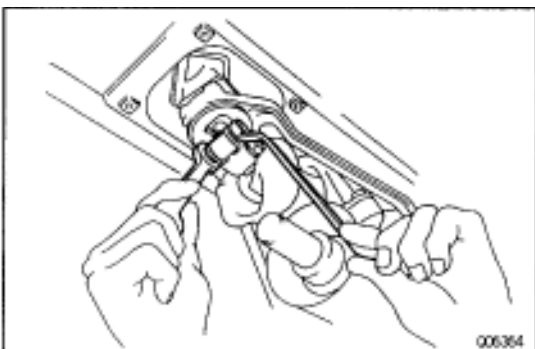

10. REMOVE TRANSMISSION SHIFT LEVER

- (a) Remove the bolt and nut.
Torque: 19 N·m (195 kgf·cm, 14 ft·lbf)
- (b) Remove the transmission shift lever, inside the vehicle.

11. REMOVE CLUTCH RELEASE CYLINDER AND GROUND CABLE

- (a) Remove the 2 bolts and clutch release cylinder.
Torque: 13 N·m (130 kgf·cm, 9 ft·lbf)
- (b) Remove the bolt, ground cable and flexible hose bracket.
Torque: 37 N·m (380 kgf·cm, 27 ft·lbf)

12. REMOVE STARTER

- (a) Remove the nut and disconnect the starter wire.
- (b) Disconnect the starter wire connector.
- (c) Remove the 2 bolts and starter.
Torque: 39 N·m (400 kgf·cm, 29 ft·lbf)

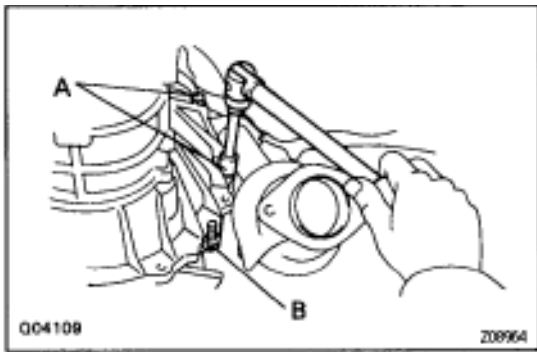
13. DISCONNECT BACK-UP LIGHT SWITCH CONNECTOR**14. DISCONNECT VEHICLE SPEED SENSOR CONNECTOR****15. REMOVE TRANSMISSION MOUNTING BOLTS**

Remove the 3 transmission mounting bolts.

Torque:

Bolt A: 72 N·m (730 kgf·cm, 53 ft·lbf)

Bolt B: 37 N·m (380 kgf·cm, 27 ft·lbf)

16. JACK UP TRANSMISSION SLIGHTLY

Using a transmission jack, support the transmission.

17. REMOVE REAR ENGINE MOUNTING MEMBER

- (a) Remove the 4 bolts and nuts.

Torque:

Nut: 13 N·m (135 kgf·cm, 10 ft·lbf)

Bolt: 25 N·m (260 kgf·cm, 19 ft·lbf)

- (b) Remove the rear engine mounting member.

18. REMOVE ENGINE REAR MOUNTING

Remove the 3 bolts and engine rear mounting from the transmission.

Torque: 25 N·m (250 kgf·cm, 18 ft·lbf)

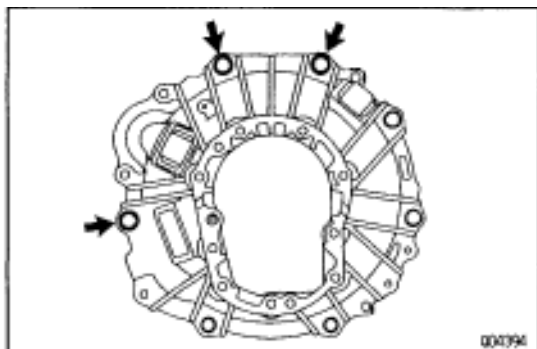
**19. REMOVE TRANSMISSION**

- (a) Remove the 3 remaining transmission mounting bolts.
Torque: 72 N·m (730 kgf·cm, 53 ft·lbf)
- (b) Lower the engine rear side and remove the transmission from the engine.

COMPONENT PARTS REMOVAL COMPONENTS

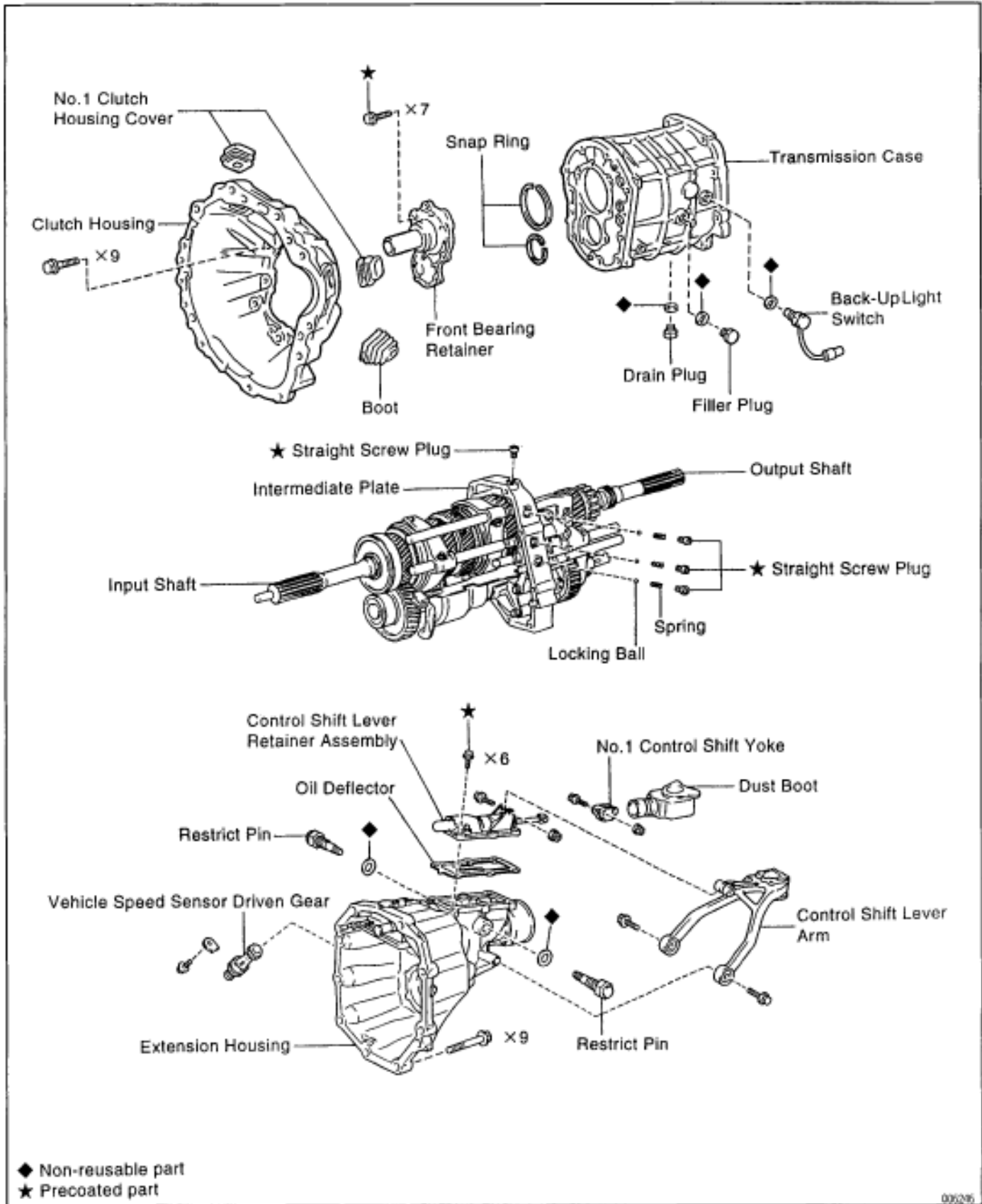

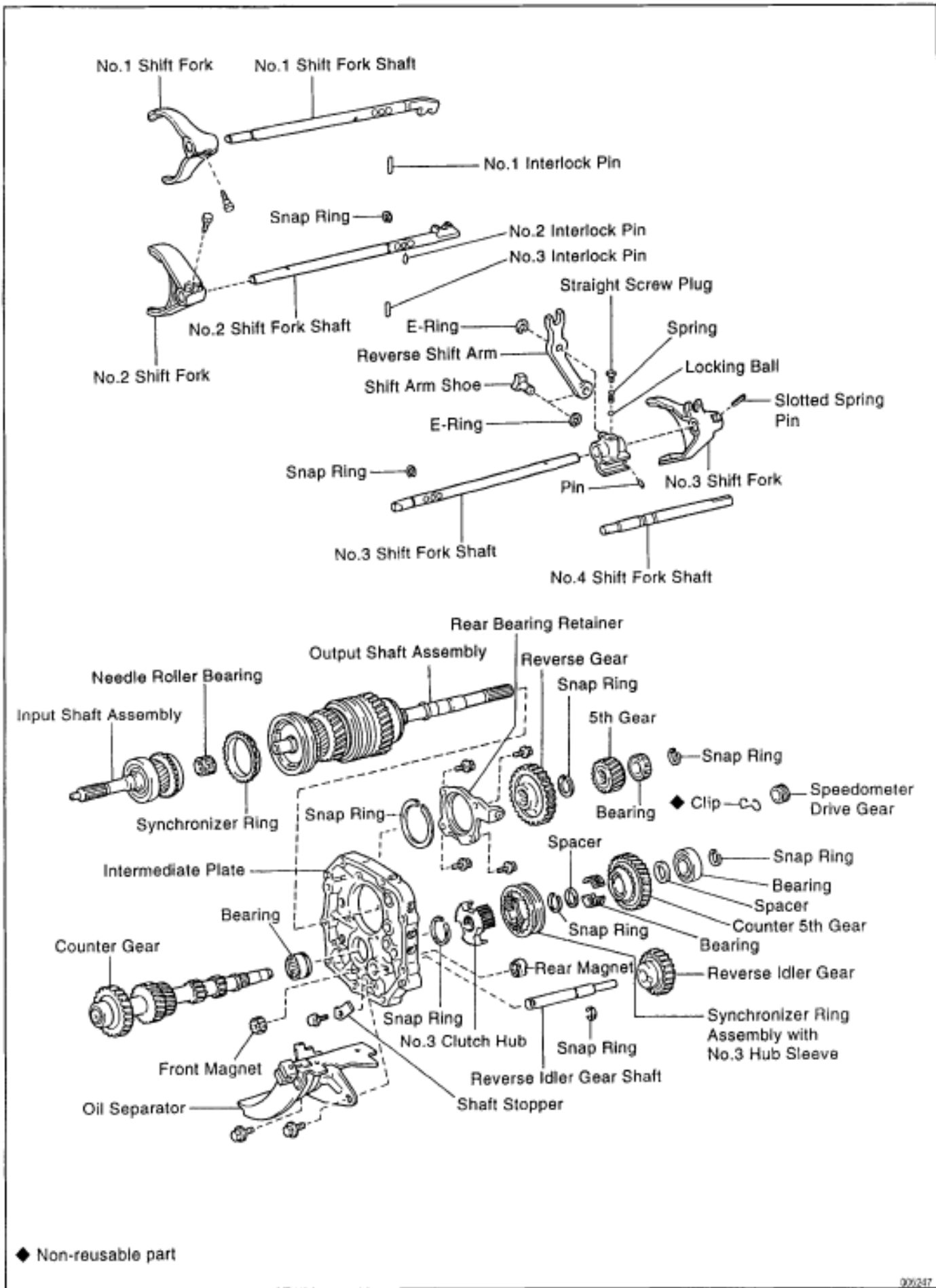

BASIC SUBASSEMBLY SEPARATION

Assembly is in the reverse order of separation.

1. REMOVE BACK-UP LIGHT SWITCH

Torque: 40 N·m (410 kgf·cm, 30 ft·lbf)

2. REMOVE VEHICLE SPEED SENSOR DRIVEN GEAR

Torque: 13 N·m (130 kgf·cm, 9 ft·lbf)

3. REMOVE CLUTCH HOUSING FROM TRANSMISSION CASE

Remove the 9 bolts and clutch housing from the transmission case.

Torque: 37 N·m (380 kgf·cm, 27 ft·lbf)

4. REMOVE CONTROL SHIFT LEVER ARM, DUST BOOT AND NO. 1 CONTROL SHIFT YOKE

(a) Remove the 3 mounting bolts and control shift lever arm.

Torque:

Bolt B: 25 N·m (250 kgf·cm, 18 ft·lbf)

Bolt C: 19 N·m (195 kgf·cm, 14 ft·lbf)

(b) Remove the dust boot.

(c) Remove the bolt and No. 1 control shift yoke from the control shaft.

Torque:

Bolt A: 19 N·m (195 kgf·cm, 14 ft·lbf)

5. REMOVE CONTROL SHIFT LEVER RETAINER ASSEMBLY

(a) Remove the 6 bolts.

Torque: 18 N·m (185 kgf·cm, 13 ft·lbf)

(b) Remove the control shift lever retainer assembly and oil deflector.

6. REMOVE 2 RESTRICT PINS

INSTALLATION HINT: Install the black pin on the reverse gear/5th gear side.

Torque: 40 N·m (410 kgf·cm, 30 ft·lbf)

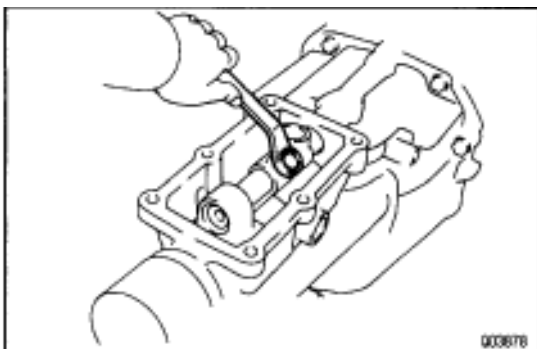
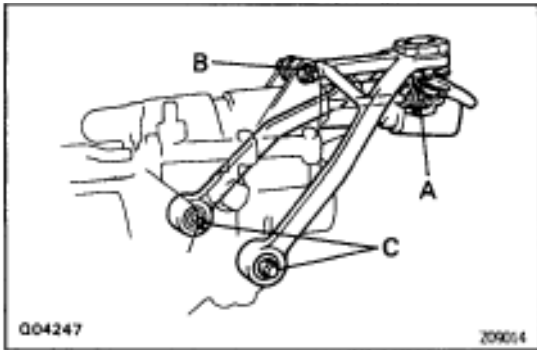

7. REMOVE EXTENSION HOUSING

(a) Remove the shift lever housing set bolt.

Torque: 39 N·m (400 kgf·cm, 29 ft·lbf)

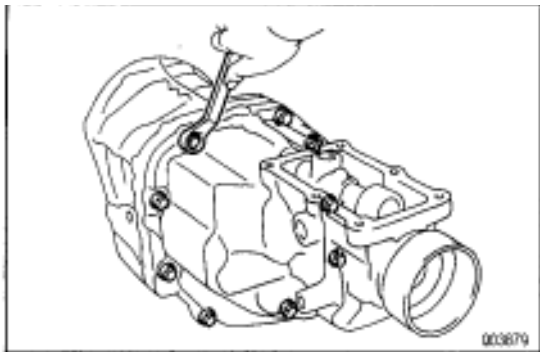

- (b) Remove the 9 bolts.
Torque: 37 N·m (380 kgf·cm, 27 ft·lbf)

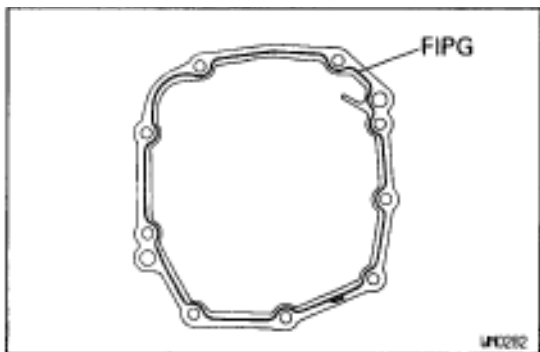

INSTALLATION HINT:

- Remove any FIPG material and be careful not to drop oil on the contacting surface of the transmission case or intermediate plate.
- Apply FIPG to the transmission case, as shown.

FIPG:

Part No.08826-00090, THREE BOND 1281 or equivalent

- Align each bearing outer race and each shift fork shaft end with the case holes.
- Using a plastic hammer, tap on the case to install it.

- (c) Using a plastic hammer, carefully tap the extension housing.
 (d) Disengage the shift and select lever from the shift head.
 (e) Pull out the extension housing.

8. REMOVE FRONT BEARING RETAINER AND BEARING SNAP RINGS

- (a) Remove the 7 bolts and front bearing retainer.
Torque: 25 N·m (250 kgf·cm, 18 ft·lbf)

INSTALLATION HINT:

- Remove any FIPG material and be careful not to drop oil on the contacting surface of the front bearing retainer or transmission case.
- Apply FIPG to the retainer, as shown and install it to the transmission case.

FIPG:

Part No.08826-00090, THREE BOND 1281 or equivalent

- Apply sealant to the bolt threads.

Sealant:

Part No.08833-00080, THREE BOND 1344, LOCTITE 242 or equivalent

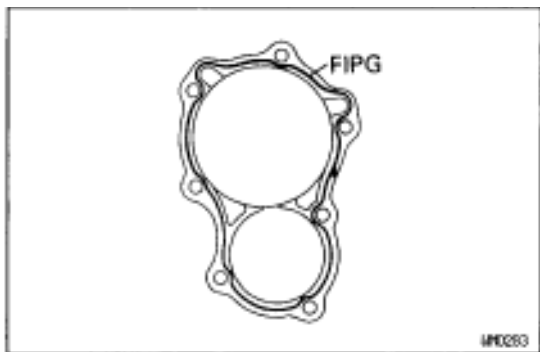

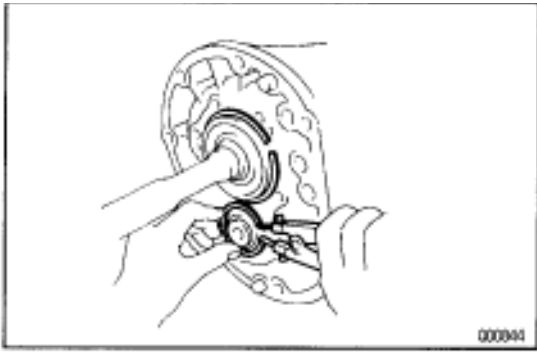

- (b) Using a snap ring expander, remove the 2 bearing snap rings.
- 9. SEPARATE INTERMEDIATE PLATE FROM TRANSMISSION CASE**
- (a) Using a plastic hammer, carefully tap the transmission case.
- (b) Pull the transmission case from the intermediate plate.

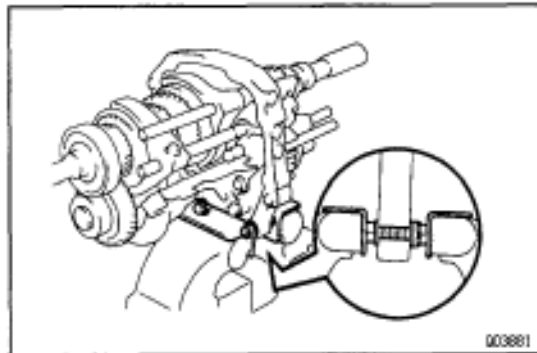

- 10. MOUNT INTERMEDIATE PLATE IN VISE**
- (a) Use the 2 long clutch housing bolts, plate washers and suitable nuts, as shown.
- NOTICE: Increase or decrease plate washers so that the bolt tip does not stand proud of the nut.**
- (b) Mount the intermediate plate in a vise.

11. REMOVE OIL SEPARATOR

- Remove the 2 bolts and oil separator.
- Torque: 18 N·m (185 kgf·cm, 13 ft·lbf)**

12. REMOVE FRONT MAGNET

13. REMOVE LOCKING BALL AND SPRING

- (a) Using a hexagon wrench, remove the 4 straight screw plugs.
- Torque: 25 N·m (250 kgf·cm, 18 ft·lbf)**

INSTALLATION HINT: Apply sealant to the plug threads.

Sealant:

Part No.08833-00080, THREE BOND 1344, LOC-TITE 242 or equivalent

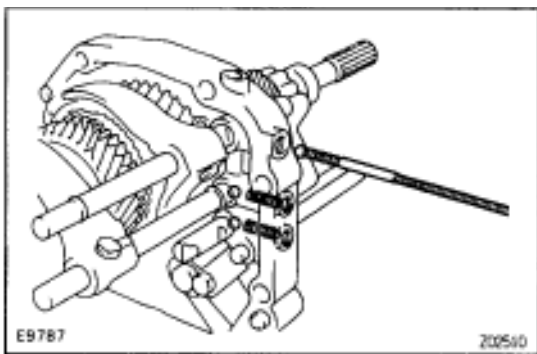
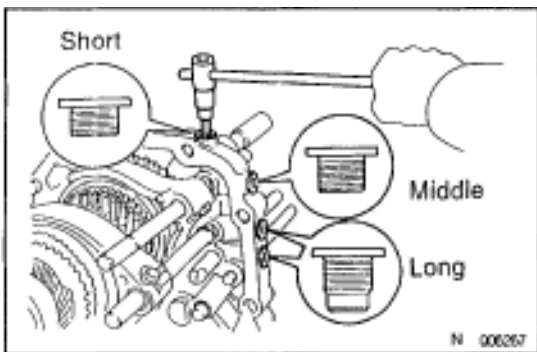

- (b) Using a magnetic finger, remove the 3 springs and balls.

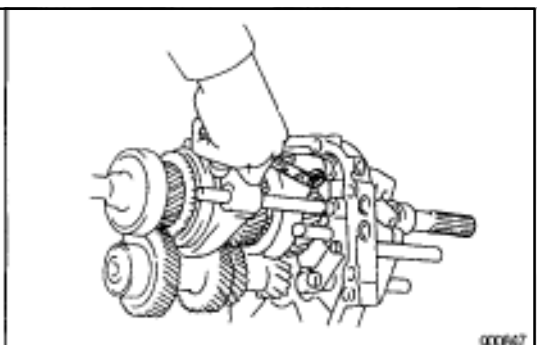

14. REMOVE SHIFT FORKS, SHIFT FORK SHAFTS AND REVERSE IDLER GEAR

- (a) Remove the No. 1 shift fork set bolt.
- Torque: 20 N·m (200 kgf·cm, 14 ft·lbf)**

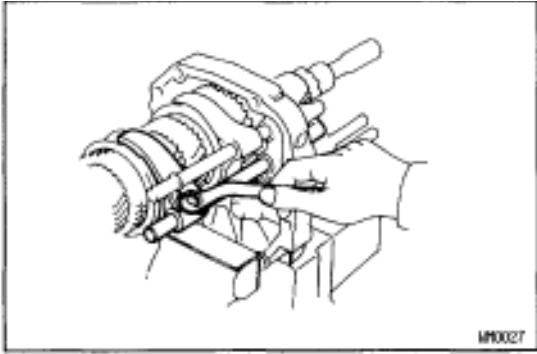

- (b) Remove the No.2 shift fork set bolt.
Torque: 20 N·m (200 kgf·cm, 14 ft·lbf)

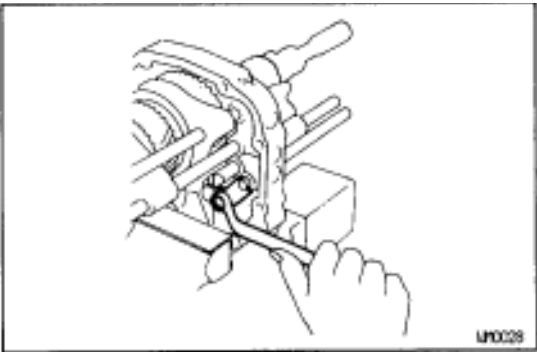

- (c) Remove the bolt and reverse idler gear shaft stopper.
Torque: 25 N·m (250 kgf·cm, 18 ft·lbf)

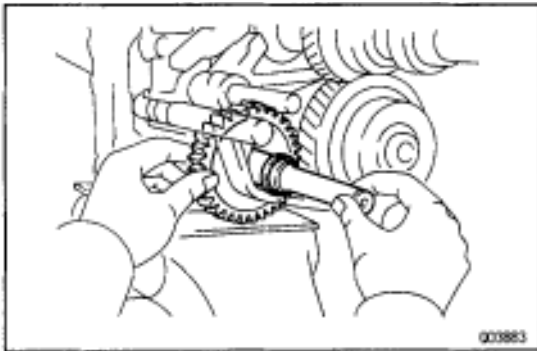

- (d) Remove the reverse idler gear and shaft with the snap ring.

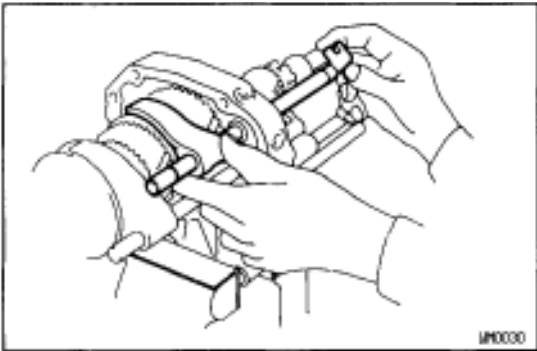

- (e) Remove the No.1 shift fork and shaft.

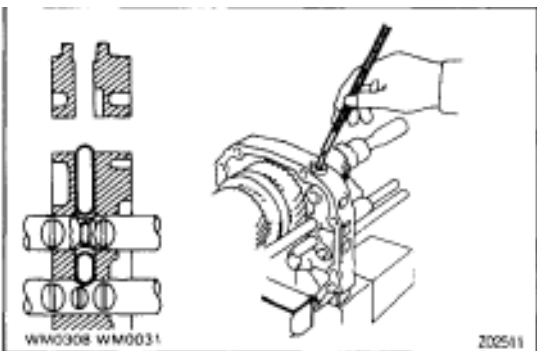

- (f) Using a magnetic finger, remove the No.1 and No.2 interlock pins.
INSTALLATION HINT: Apply MP grease to the No.1 and No.2 interlock pins.

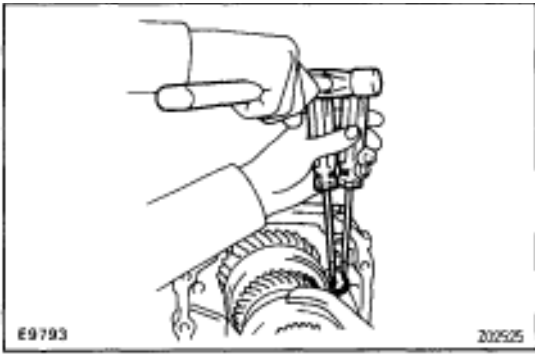

- (g) Using 2 screwdrivers and a hammer, tap out the snap ring of No. 2 shaft.

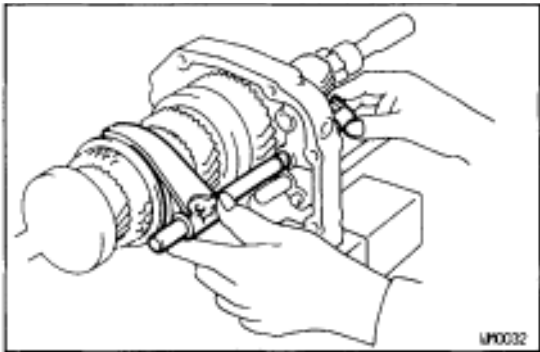

- (h) Remove the No. 2 shift fork and shaft.

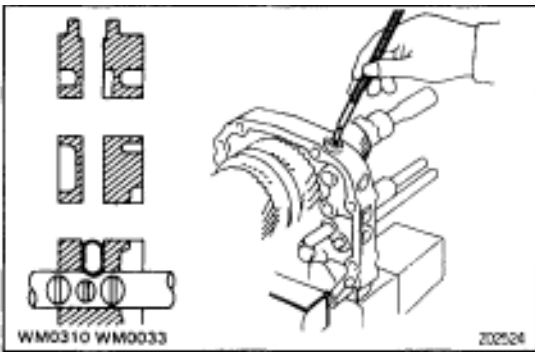

- (i) Using a magnetic finger, remove the No.3 interlock pin.
 INSTALLATION HINT: Apply MP grease to the No.3 interlock pin.

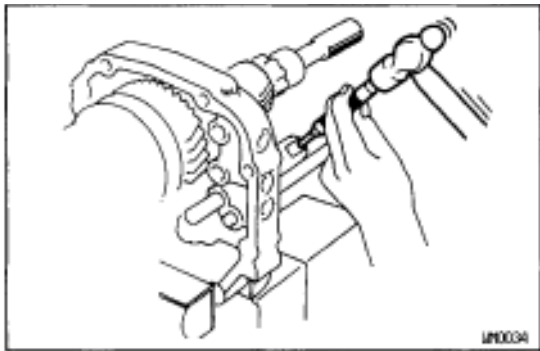

- (j) Using a pin punch and hammer, drive out the No. 3 fork shaft pin.

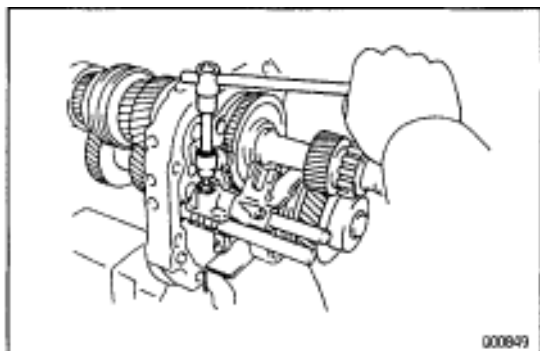

- (k) Using a hexagon wrench, remove the plug.
Torque: 25 N·m (250 kgf·cm, 18 ft·lbf)
 INSTALLATION HINT: Apply sealant to the plug.
Sealant:
Part No.08833-00080, THREE BOND 1344, LOCTITE 242
or equivalent

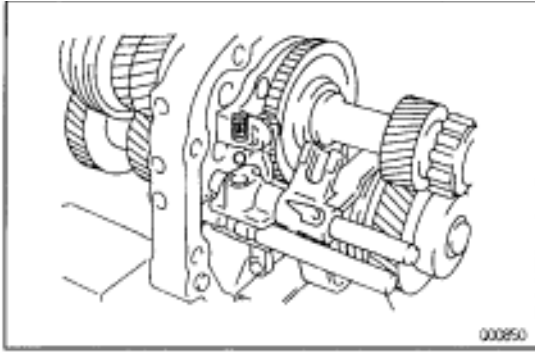

- (l) Using a magnetic finger, remove the spring and ball.

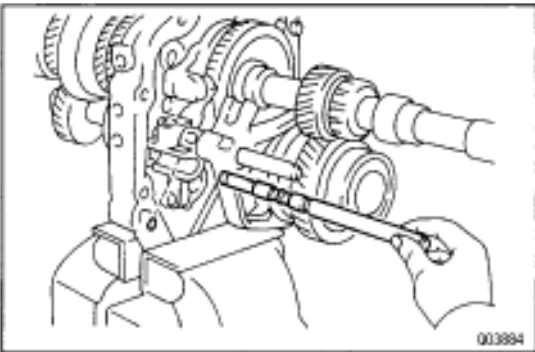

- (m) Pull out the No.4 shift fork shaft.
 (n) Remove the interlock pin.

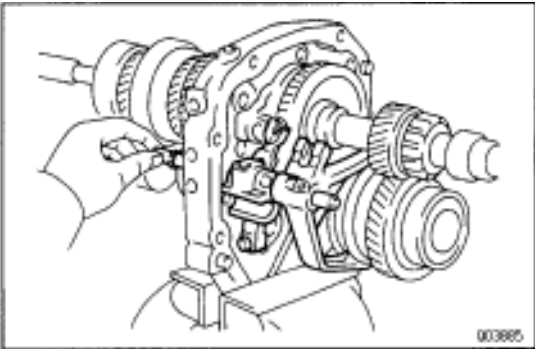

- (o) Remove the No.3 shift fork, fork shaft and reverse shift arm with the snap ring.

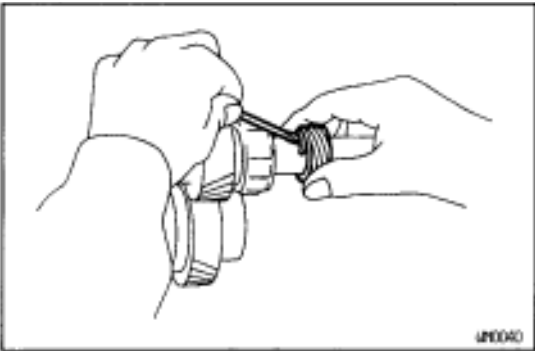

15. REMOVE SPEEDOMETER DRIVE GEAR

Pry out both ends of the clip and remove the drive gear.

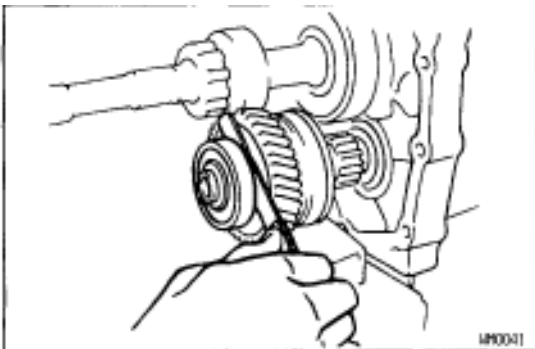

16. INSPECT COUNTER 5TH GEAR THRUST CLEARANCE

Using a feeler gauge, measure the counter 5th gear thrust clearance.

Standard clearance:

0.10–0.41 mm (0.0039–0.0161 in.)

Maximum clearance:

0.46 mm (0.0181 in.)

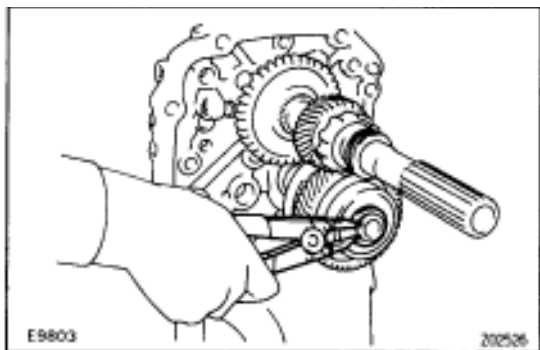

17. REMOVE COUNTER REAR BEARING, SPACER, COUNTER 5TH GEAR AND NEEDLE ROLLER BEARING

- (a) Using a snap ring expander, remove the snap ring.
INSTALLATION HINT: Select a snap ring that will allow minimum axial play.

Mark	Thickness mm (in.)
1	1.90–1.95 (0.0748–0.0768)
2	1.96–2.01 (0.0772–0.0791)
3	2.02–2.07 (0.0795–0.0815)
4	2.08–2.13 (0.0819–0.0839)
5	2.14–2.19 (0.0843–0.0862)
6	2.20–2.25 (0.0866–0.0886)
7	2.26–2.31 (0.0890–0.0909)

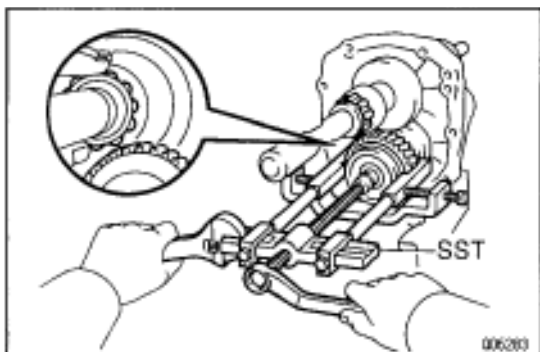

- (b) Using SST, remove the rear bearing, spacer, 5th gear and bearing.

SST 09950-40010

NOTICE: Be careful not to catch the output shaft rear bearing roller on the counter 5th gear.

INSTALLATION HINT:

- Install the needle roller bearing to the counter 5th gear.
- Install the counter 5th gear with the 5th gear gaps aligned with the synchronizer corn ring pin.

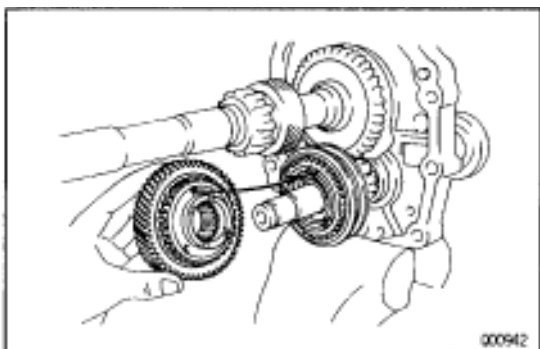

INSTALLATION HINT:

- Using a socket wrench and hammer, drive in the bearing.
- When driving in the bearing, support the counter shaft in front with 3–5 lb hammer or equivalent.

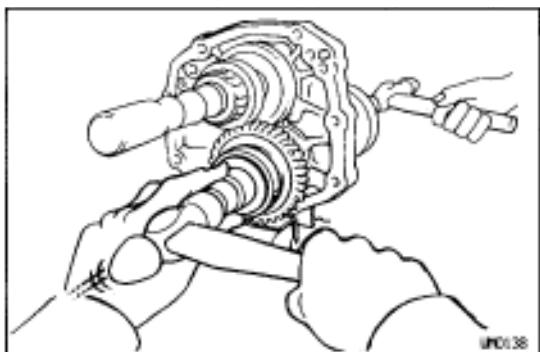

- (c) Remove the spacer.

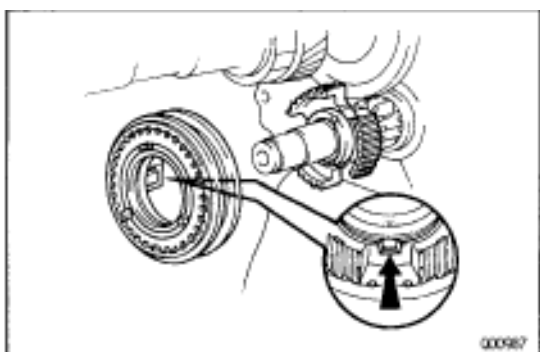

18. REMOVE SYNCHRONIZER RING ASSEMBLY WITH NO.3 HUB SLEEVE AND NO.3 CLUTCH HUB

- (a) Remove the synchronizer ring assembly with the No.3 hub sleeve from the No.3 clutch hub.

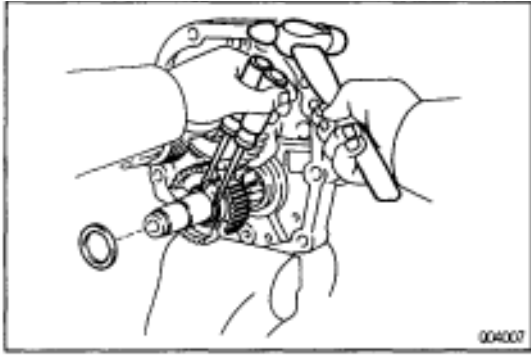

- (b) Remove the spacer.
- (c) Using 2 screwdrivers and a hammer, tap out the snap ring.
INSTALLATION HINT: Select a snap ring that will allow minimum axial play.

Mark	Thickness mm (in.)
2	2.06–2.11 (0.0811–0.0831)
3	2.12–2.17 (0.0835–0.0854)
4	2.18–2.23 (0.0858–0.0878)
5	2.24–2.29 (0.0882–0.0902)

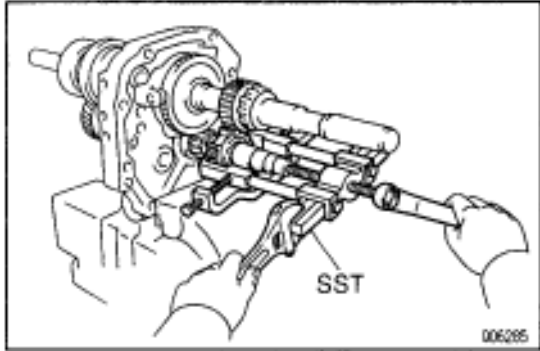

- (d) Using SST, remove the No.3 clutch hub.
SST 09950-40010

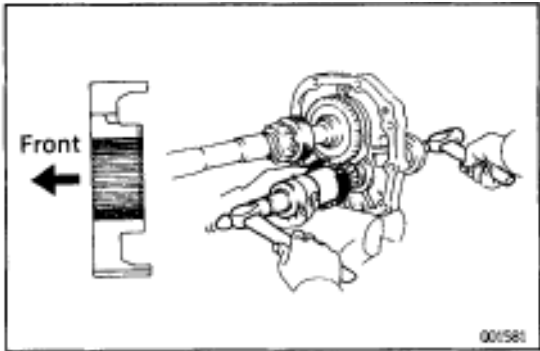

INSTALLATION HINT:

- Using SST and a hammer, drive in the No.3 clutch hub.
SST 09316-60010 (09316-00010, 09316-00070)
- When installing the No.3 clutch hub, support the counter shaft in front with a 3–5 lb hammer or equivalent.

19. REMOVE REAR MAGNET

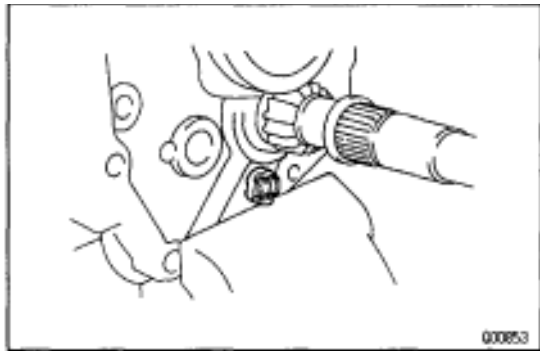

20. REMOVE OUTPUT SHAFT REAR BEARING AND 5TH GEAR

- (a) Using 2 screwdrivers and a hammer, tap out the snap ring.
INSTALLATION HINT: Select a snap ring that will allow minimum axial play.

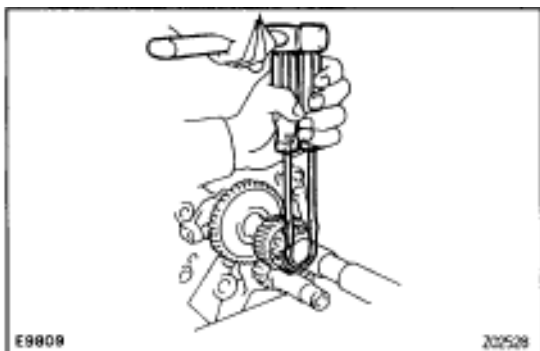

Mark	Thickness mm (in.)
8	2.31–2.36 (0.0909–0.0929)
9	2.37–2.42 (0.0933–0.0953)
10	2.43–2.48 (0.0957–0.0976)
11	2.49–2.54 (0.0980–0.1000)
12	2.55–2.60 (0.1004–0.1024)
13	2.61–2.66 (0.1028–0.1047)
14	2.68–2.73 (0.1055–0.1075)
15	2.74–2.79 (0.1079–0.1098)

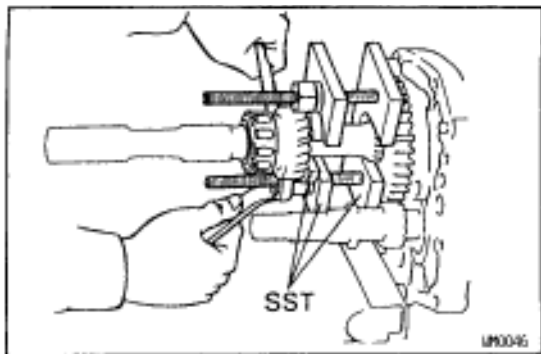

- (b) Using SST, remove the rear bearing and 5th gear.
SST 09312-20011 (09313-00030, 09313-00040, 09313-00050)

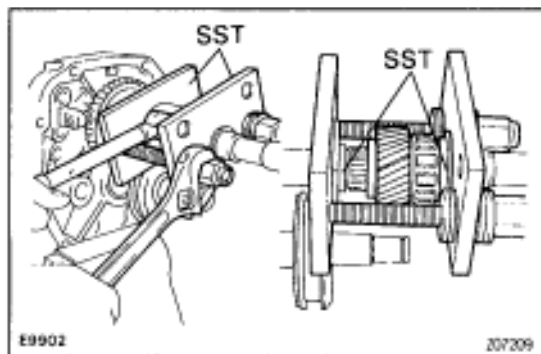

INSTALLATION HINT: Using SST, install the 5th gear and rear bearing.

- SST 09312-20011 (09313-00010, 09313-00030, 09313-00040, 09313-00050)

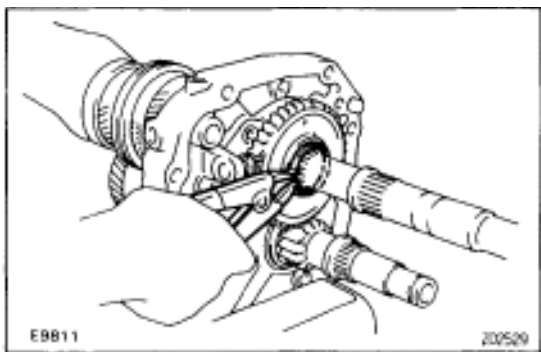

21. REMOVE REVERSE GEAR

- (a) Using a snap ring expander, remove the snap ring.
INSTALLATION HINT: Select a snap ring that will allow minimum axial play.

Mark	Thickness mm (in.)
5	2.25-2.30 (0.0886-0.0906)
11	2.30-2.35 (0.0906-0.0925)
12	2.35-2.40 (0.0925-0.0945)
13	2.40-2.45 (0.0945-0.0965)
14	2.45-2.50 (0.0965-0.0984)
15	2.50-2.55 (0.0984-0.1004)
16	2.55-2.60 (0.1004-0.1024)
17	2.61-2.66 (0.1028-0.1047)
18	2.67-2.72 (0.1051-0.1071)
19	2.73-2.78 (0.1075-0.1094)
20	2.79-2.84 (0.1098-0.1118)
21	2.85-2.90 (0.1122-0.1142)
22	2.91-2.96 (0.1146-0.1165)
23	2.97-3.02 (0.1169-0.1189)

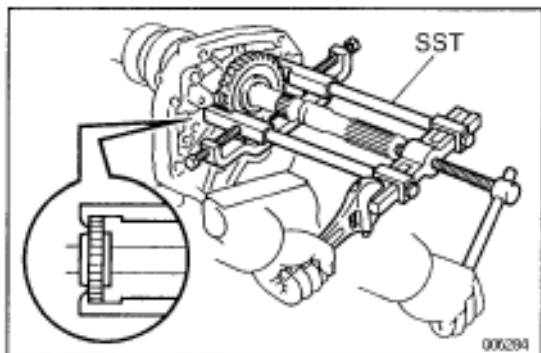

- (b) Using SST, remove the reverse gear.
SST 09950-40010

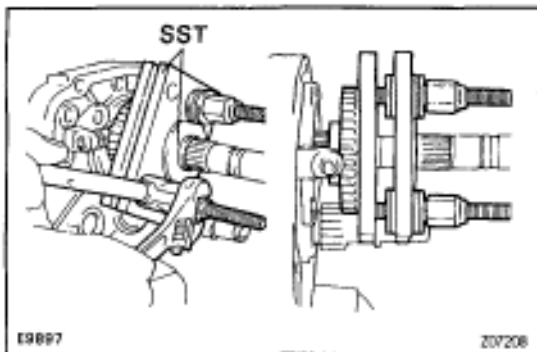

INSTALLATION HINT: Using SST, install the reverse gear.
SST 09312-20011 (09313-00030, 09313-00040, 09313-00050)

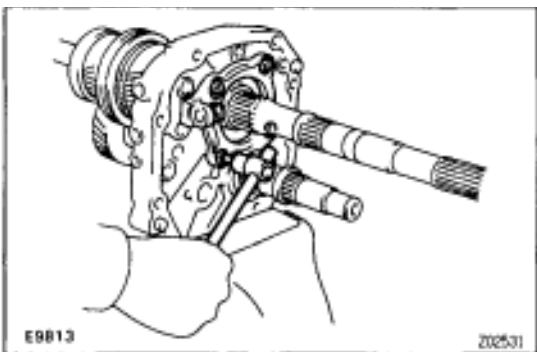

22. REMOVE REAR BEARING RETAINER

- (a) Using a torx socket wrench, unscrew the 4 torx screws and remove the retainer.

Torque: 18 N·m (185 kgf·cm, 13 ft·lbf)

(Torx socket wrench T40 09042-00020)

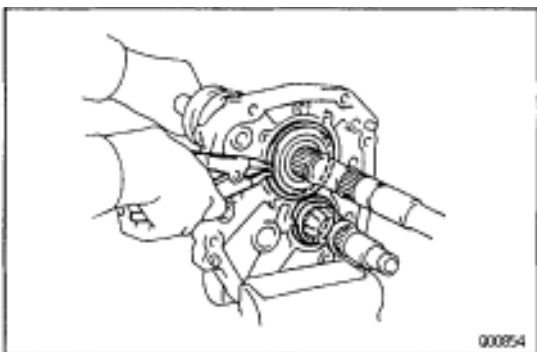

- (b) Using a snap ring expander, remove the 2 snap rings.
INSTALLATION HINT: Be sure the snap ring is flush with the intermediate plate surface.

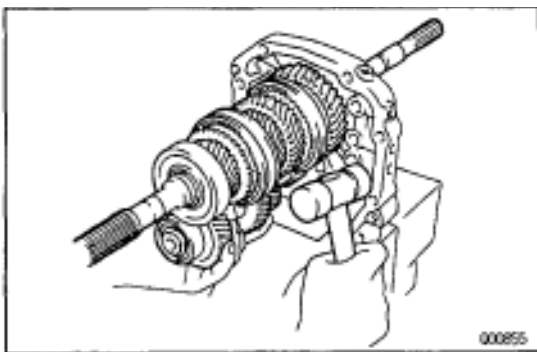

23. REMOVE OUTPUT SHAFT AND COUNTER GEAR FROM INTERMEDIATE PLATE

- (a) Remove the output shaft, input shaft and counter gear as a unit from the intermediate plate by pulling on the counter gear and tapping on the intermediate plate with a plastic hammer.
(b) Remove the input shaft from the output shaft.

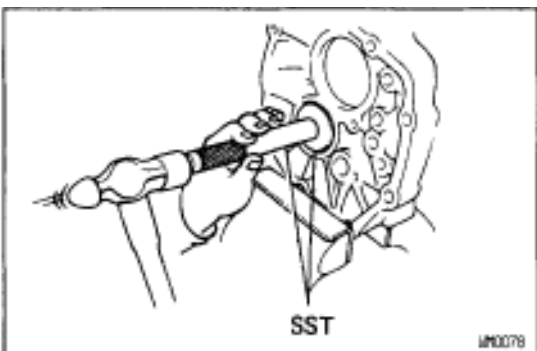

INSTALLATION HINT:

- Before installing the output shaft, use SST to remove the counter gear center bearing outer race.
SST 09608-35014 (09608-06020, 09608-06090)
- Install the outer race after installing the counter gear.

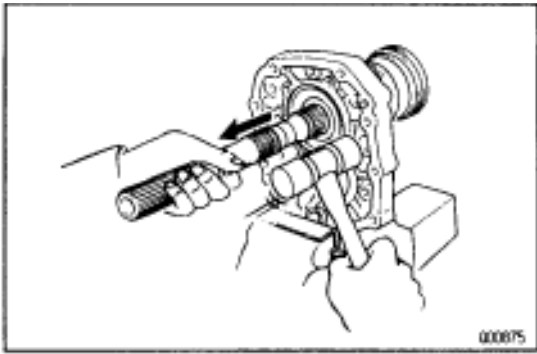

- Install the output shaft into the intermediate plate by pulling on the output shaft and tapping on the intermediate plate.

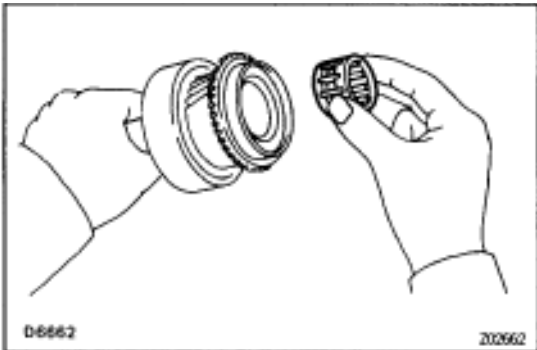

INSTALLATION HINT:

- Apply gear oil to the needle roller bearing.
- Install the needle roller bearing to the input shaft.

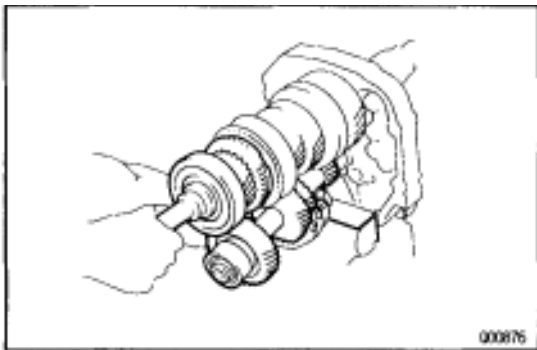

- Install the input shaft and counter gear together.

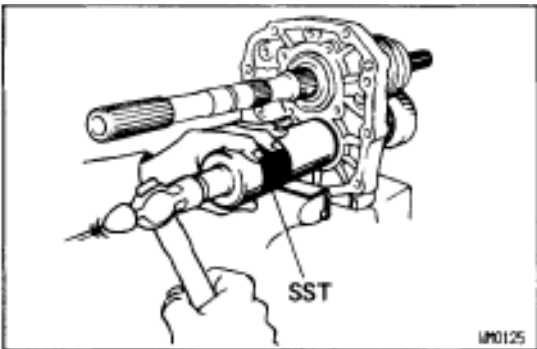

- Using SST and a hammer, install the counter gear center bearing outer race.

SST 09316-60010 (09316-00010)

NOTICE: Be careful not to damage the bearing rollers.

INPUT SHAFT COMPONENTS

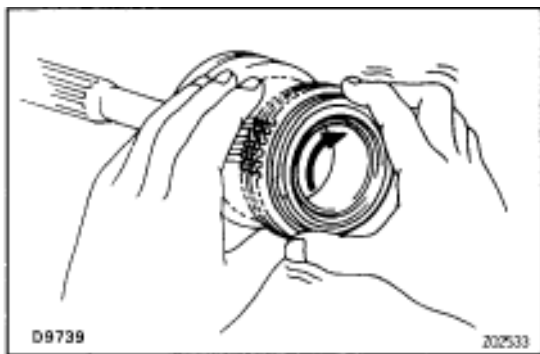
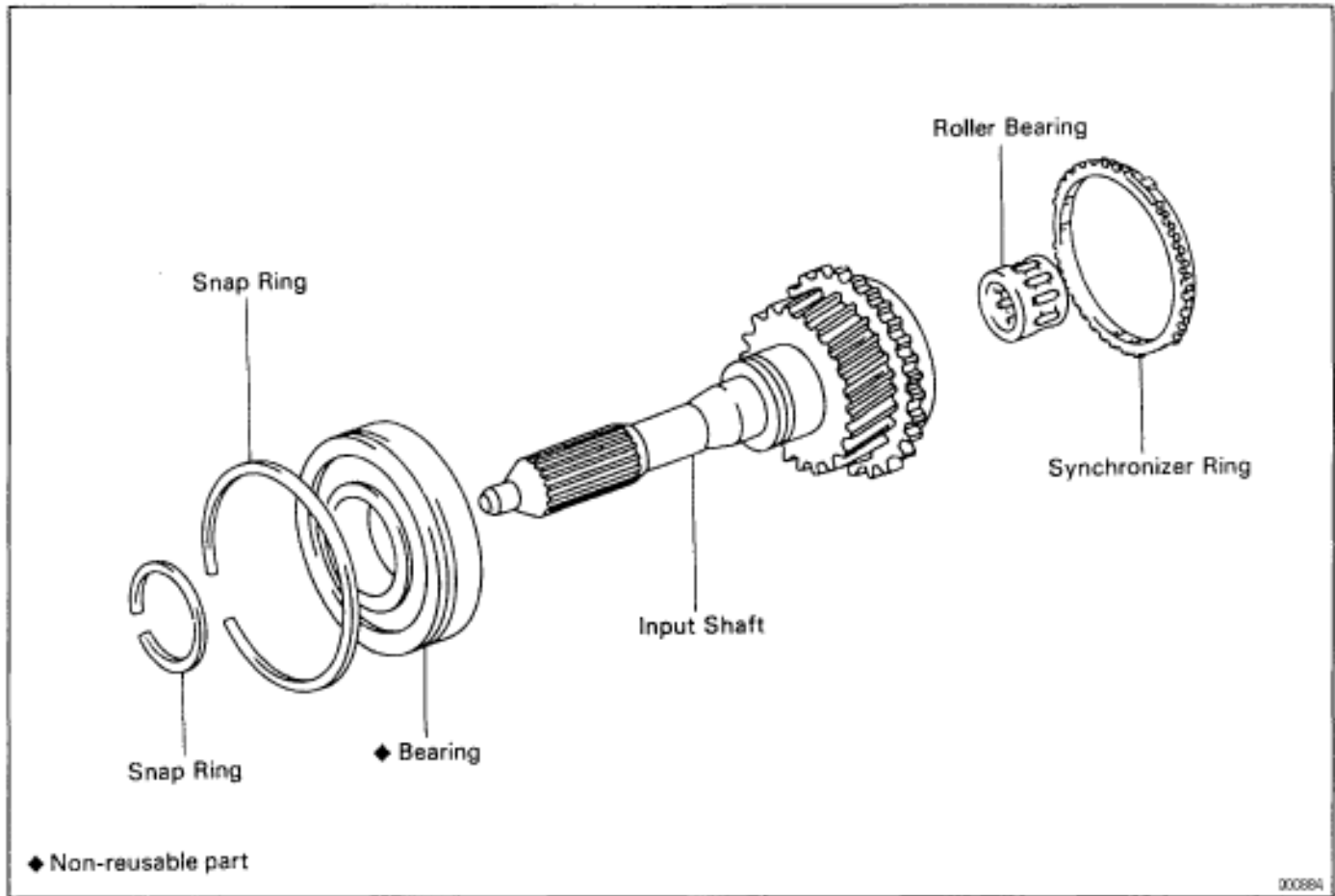

INPUT SHAFT INSPECTION

INSPECT SYNCHRONIZER RING

- Check for wear or damage.
- Check the braking effect of the synchronizer ring. Turn the synchronizer ring in one direction while pushing it to the gear cone. Check that the ring locks. If the braking effect is insufficient, apply a small amount of fine lapping compound between the synchronizer ring and gear cone. Lightly rub the synchronizer ring and gear cone together. **NOTICE: Ensure the fine lapping compound is completely washed off after rubbing.**
- Check again the braking effect of the synchronizer ring. If it does not lock, replace the synchronizer ring.

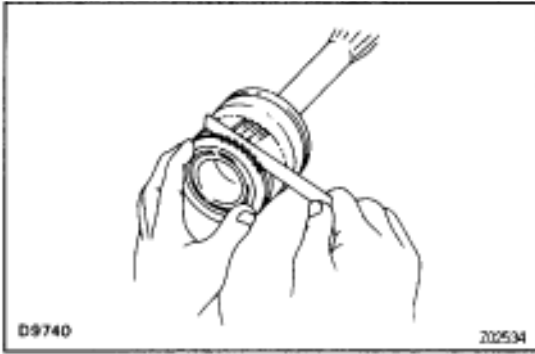

- (d) Using a feeler gauge, measure the clearance between the synchronizer ring back and gear spline end.

Minimum clearance:

0.5 mm (0.020 in.)

HINT: When replacing either a synchronizer ring or gear, apply a small amount of fine lapping compound between the synchronizer ring and gear cone.

Lightly rub the synchronizer ring and gear cone together.

NOTICE:

- **When replacing both the synchronizer ring and gear, there is no need to apply any compound or to rub them together.**
- **NOTICE: Ensure the fine lapping compound is completely washed off after rubbing.**

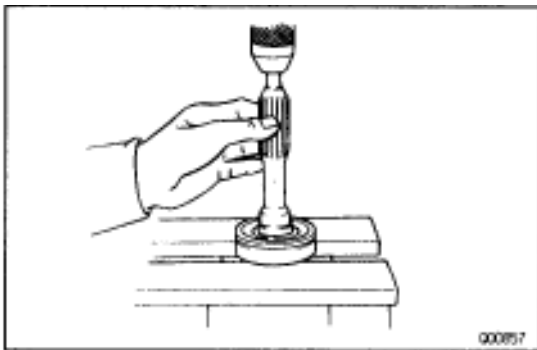

BEARING REPLACEMENT

IF NECESSARY, REPLACE INPUT SHAFT BEARING

- (a) Using a snap ring expander, remove the snap ring.
 (b) Using a press, remove the bearing.

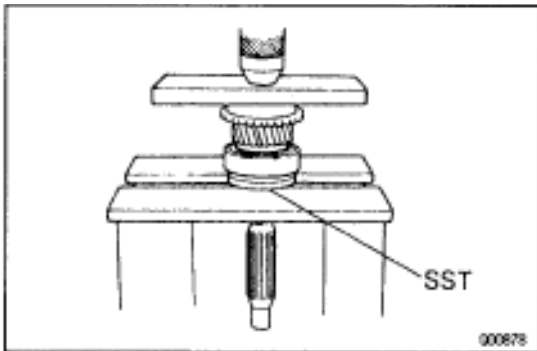

- (c) Using SST and a press, install a new bearing.
 SST 09506–35010
 (d) Select a snap ring that will allow minimum axial play.

Mark	Thickness mm (in.)
1	2.05–2.10 (0.0807–0.0827)
2	2.10–2.15 (0.0827–0.0846)
3	2.15–2.20 (0.0846–0.0866)
4	2.20–2.25 (0.0866–0.0886)
5	2.25–2.30 (0.0886–0.0906)
11	2.30–2.35 (0.0906–0.0925)
12	2.35–2.40 (0.0925–0.0945)

- (e) Using a snap ring expander, install the snap ring.

OUTPUT SHAFT COMPONENTS

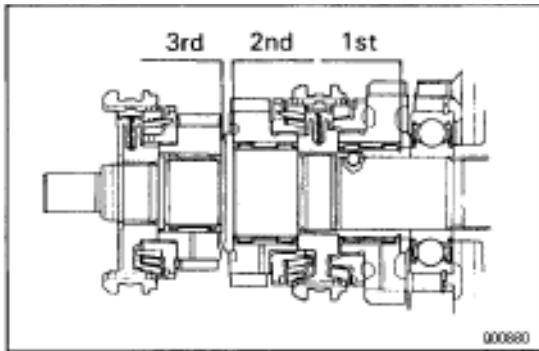
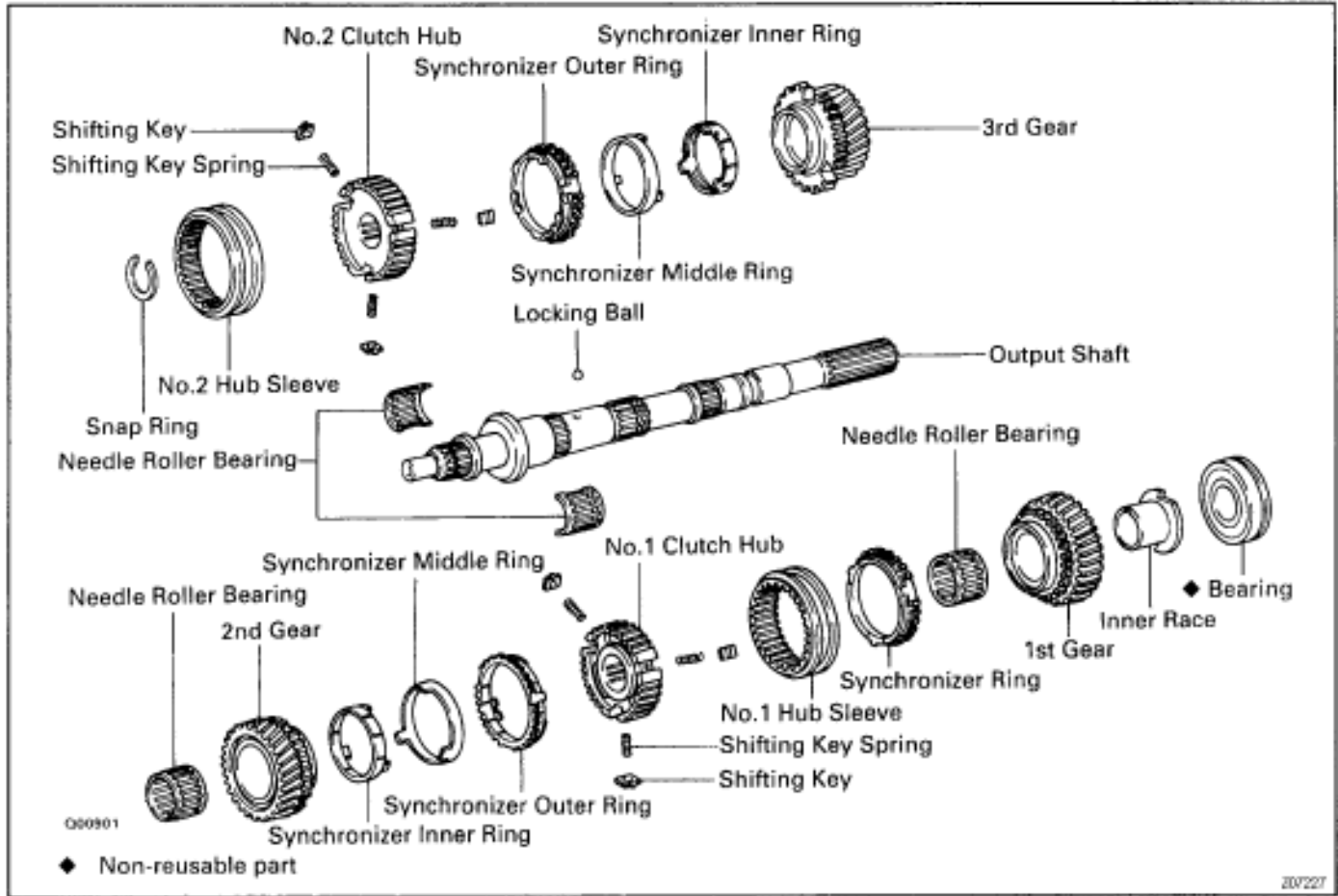

OUTPUT SHAFT DISASSEMBLY

1. INSPECT EACH GEAR THRUST CLEARANCE

Using a feeler gauge, measure the thrust clearance of each gear.

Standard clearance:

0.10–0.25 mm (0.0039–0.0098 in.)

Maximum clearance:

0.30 mm (0.0118 in.)

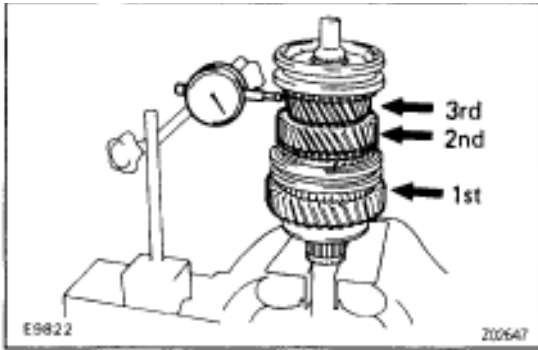

2. INSPECT EACH GEAR RADIAL CLEARANCE

Using a dial indicator, measure the radial clearance of each gear.

Standard clearance:

1st and 2nd gear

0.009–0.060 mm (0.0004–0.0024 in.)

3rd gear

0.015–0.066 mm (0.0006–0.0026 in.)

Maximum clearance:

1st and 2nd gear

0.150 mm (0.0059 in.)

3rd gear

0.200 mm (0.0079 in.)

If the clearance exceeds the maximum, replace the gear, shaft or needle roller bearing.

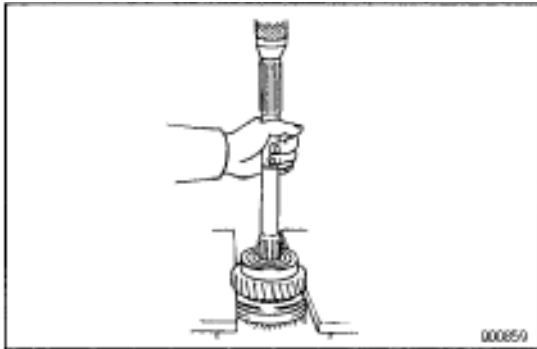

3. REMOVE OUTPUT SHAFT CENTER BEARING AND 1ST GEAR ASSEMBLY

(a) Shift the No.1 hub sleeve onto the 2nd gear.

(b) Using a press, remove the center bearing, 1st gear, needle roller bearing, inner race and synchronizer ring.

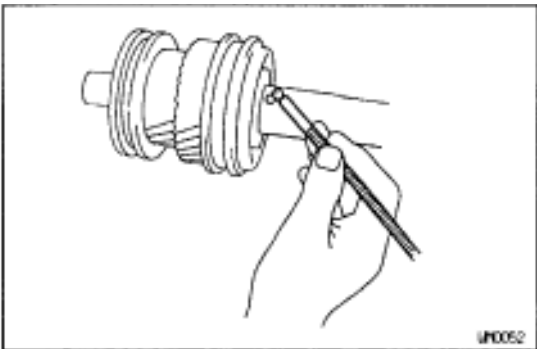

4. REMOVE LOCKING BALL

Using a magnetic finger, remove the locking ball.

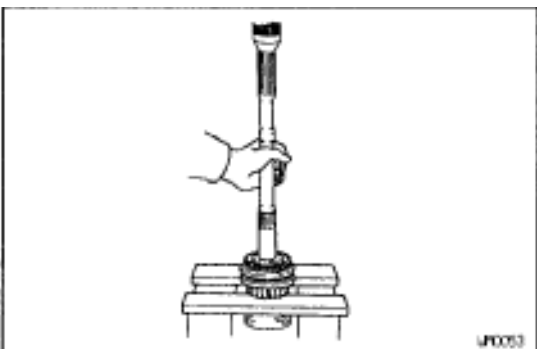

5. REMOVE NO. 1 HUB SLEEVE ASSEMBLY, 2 ND GEAR AND NEEDLE ROLLER BEARING

Using a press, remove the parts from the shaft as an assembly.

6. REMOVE NO.1 HUB SLEEVE, SHIFTING KEYS AND SPRINGS FROM NO. 1 CLUTCH HUB

(a) Remove the No. 1 clutch hub from the No. 1 hub sleeve.

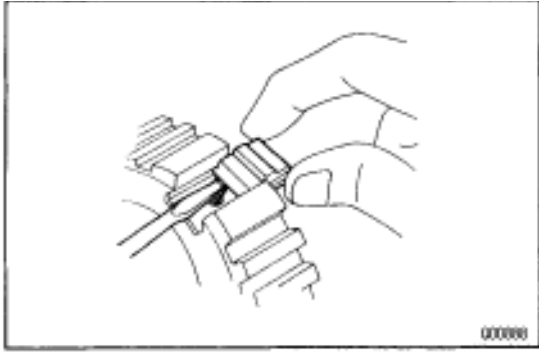

(b) Push the shifting key spring with a screwdriver, remove the 3 shifting keys and key springs.

7. REMOVE NO.2 HUB SLEEVE ASSEMBLY AND 3RD GEAR

(a) Using a snap ring expander, remove the snap ring.

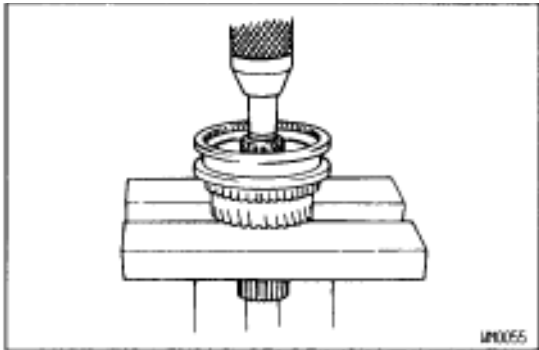

(b) Using a press, remove the No.2 hub sleeve, synchronizer ring and 3rd gear.

8. REMOVE NO.2 HUB SLEEVE, SHIFTING KEYS AND SPRINGS FROM NO.2 CLUTCH HUB

(a) Remove the No. 2 clutch hub from the No. 2 hub sleeve.

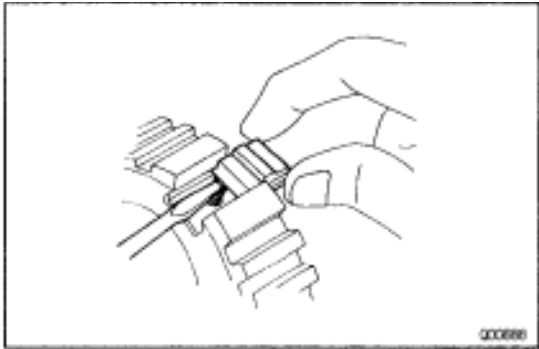

(b) Push the shifting key spring with a screwdriver, remove the 3 shifting keys and key springs.

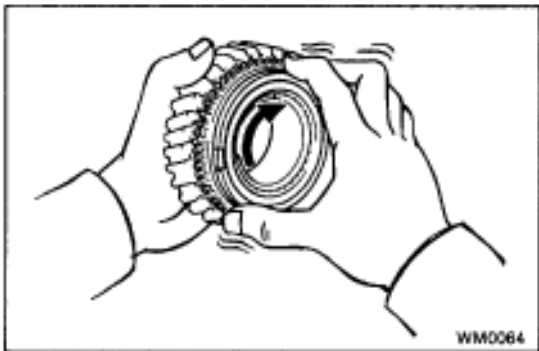

OUTPUT SHAFT COMPONENT PARTS INSPECTION

1. INSPECT 1ST GEAR SYNCHRONIZER RING

(a) Check for wear or damage.

(b) Check the braking effect of the synchronizer ring.

Turn the synchronizer ring in one direction while pushing it to the gear cone. Check that the ring locks.

If the braking effect is insufficient, apply a small amount of fine lapping compound between the synchronizer ring and gear cone.

Lightly rub the synchronizer ring and gear cone together.

NOTICE: Ensure the fine lapping compound is completely washed off after rubbing.

(c) Check again the braking effect of the synchronizer ring. If it does not lock, replace the synchronizer ring.

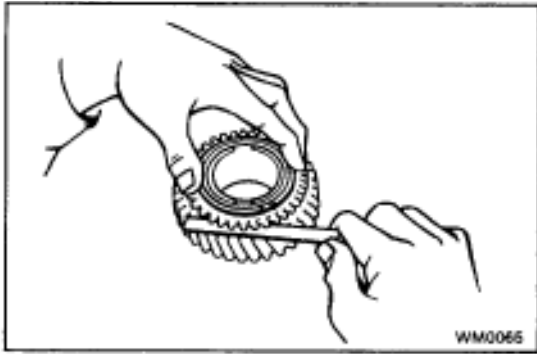

- (d) Using a feeler gauge, measure the clearance between the synchronizer ring back and gear spline end.

Minimum clearance:

0.5 mm (0.020 in.)

HINT: When replacing either a synchronizer ring or gear, apply a small amount of fine lapping compound between the synchronizer ring and gear cone.

Lightly rub the synchronizer ring and gear cone together.

NOTICE:

- **When replacing both the synchronizer ring and gear, there is no need to apply any compound or to rub them together.**
- **Ensure the fine lapping compound is completely washed off after rubbing.**

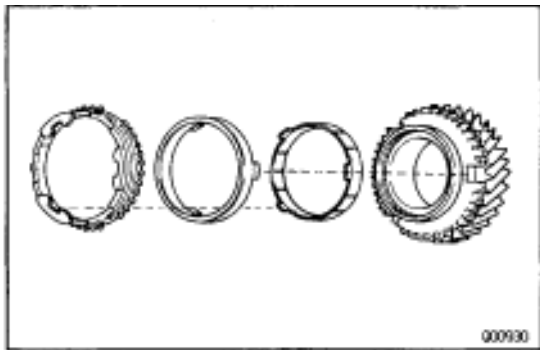

2. INSPECT 2 ND AND 3 RD GEAR SYNCHRONIZER RINGS

- (a) Check for wear or damage.
 (b) Install the synchronizer inner ring, middle ring and outer ring to each gear.

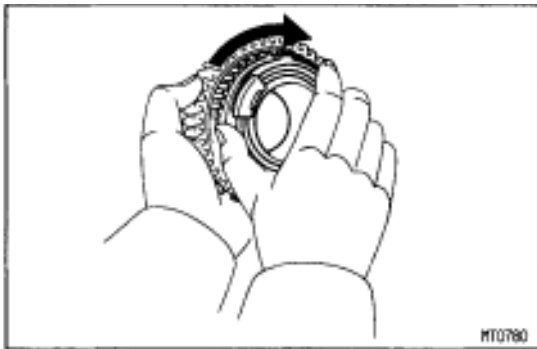

- (c) Check the braking effect of the synchronizer ring. Turn the synchronizer ring in one direction while pushing it to the gear cone. Check that the ring locks. If it does not lock, replace the synchronizer ring.

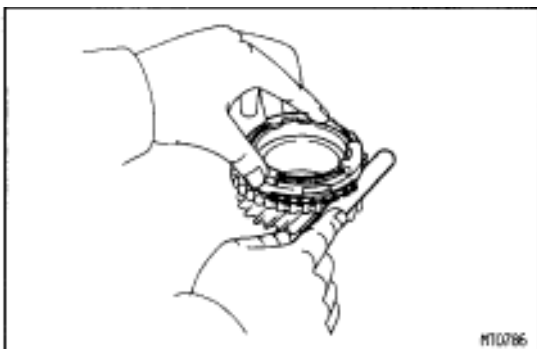

- (d) Using a feeler gauge, measure the clearance between the synchronizer ring back and the gear spline end.

Minimum clearance:

0.7 mm (0.028 in.)

If the clearance is less than the minimum, replace the synchronizer ring.

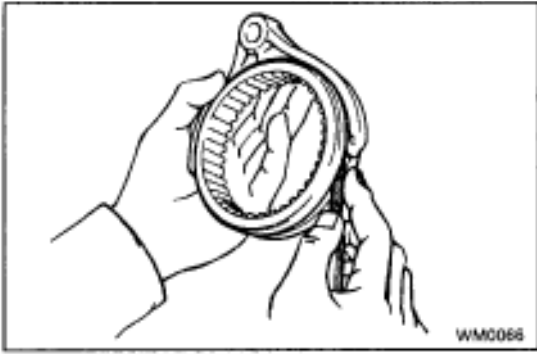

3. INSPECT CLEARANCE OF SHIFT FORKS AND HUB SLEEVES

Using a feeler gauge, measure the clearance between the hub sleeve and shift fork.

Maximum clearance:

1.0 mm (0.039 in.)

If the clearance exceeds the maximum, replace the shift fork or hub sleeve.

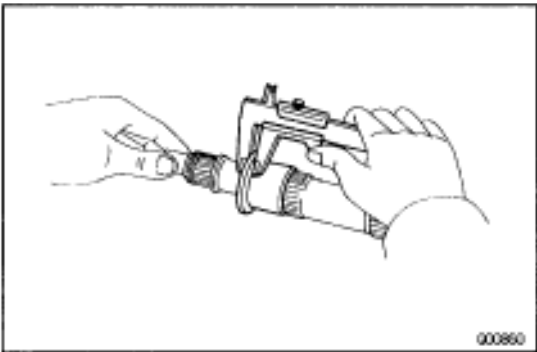

4. INSPECT OUTPUT SHAFT AND INNER RACE

- (a) Using vernier calipers, measure the output shaft flange thickness.

Minimum thickness:

5.60 mm (0.2205 in.)

If the thickness is less than the minimum, replace the output shaft.

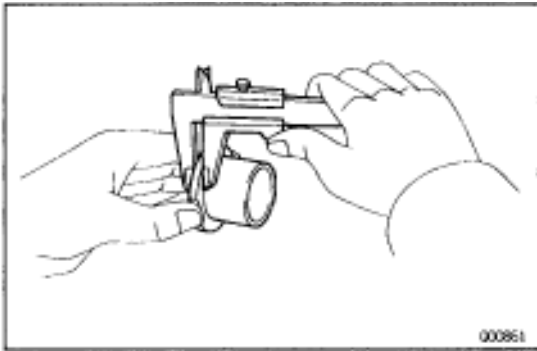

- (b) Using vernier calipers, measure the inner race flange thickness.

Minimum thickness:

4.78 mm (0.1882 in.)

If the thickness is less than the minimum, replace the inner race.

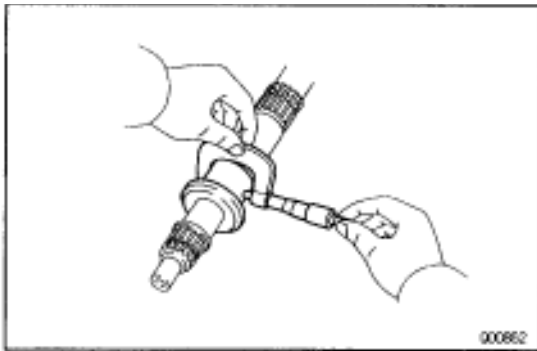

- (c) Using a micrometer, measure the outer diameter of the output shaft journal.

Minimum diameter:

2nd gear

42.975 mm (1.6919 in.)

3rd gear

31.969 mm (1.2586 in.)

If the outer diameter is less than the minimum, replace the output shaft.

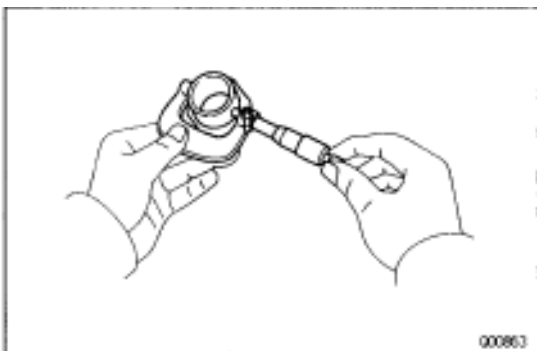

- (d) Using a micrometer, measure the outer diameter of the inner race.

Minimum diameter:

42.975 mm (1.6919 in.)

If the outer diameter is less than the minimum, replace the inner race.

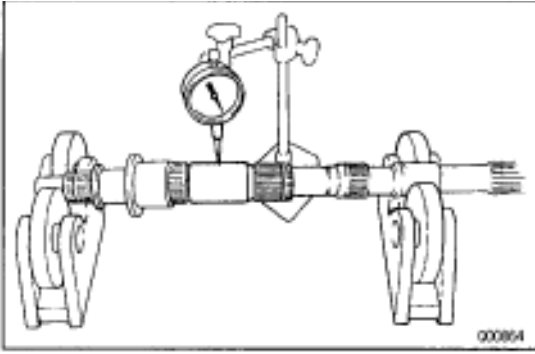

- (e) Using a dial indicator, check the shaft runout.

Maximum runout:

0.06 mm (0.0024 in.)

If the runout exceeds the maximum, replace the output shaft.

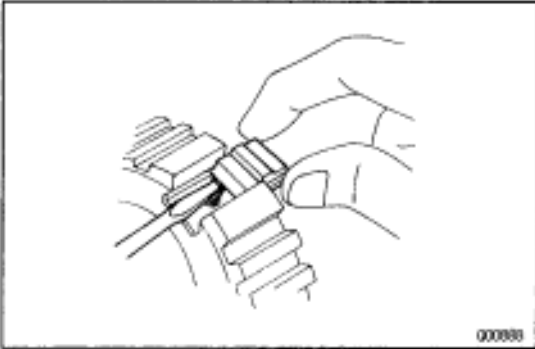

OUTPUT SHAFT ASSEMBLY

HINT: Coat all of the sliding and rotating surface with gear oil before assembly.

1. INSTALL NO.1 AND NO.2 CLUTCH HUB INTO HUB SLEEVE

- (a) Install the 3 shifting key springs to the clutch hub.
 (b) While pushing the shifting key spring with a screw-driver, install the 3 shifting keys.

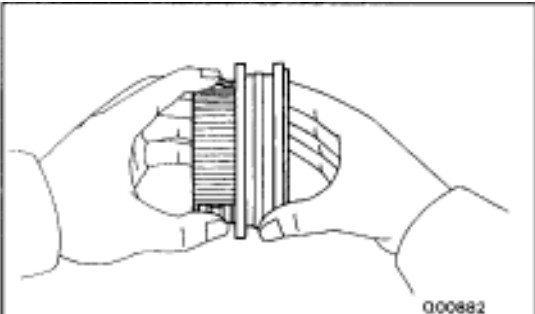

- (c) While pushing the 3 shifting keys, install the clutch hub to the hub sleeve, as shown.

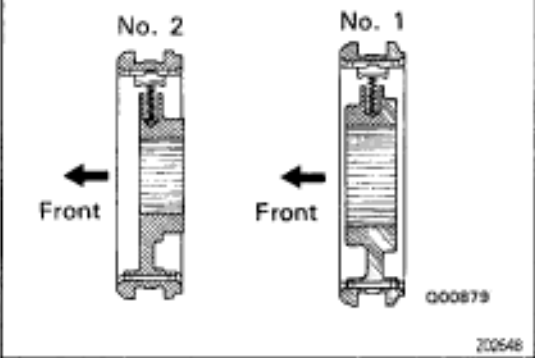

2. INSTALL 3RD GEAR AND NO.2 CLUTCH HUB ON OUTPUT SHAFT

- (a) Apply gear oil to the shaft.
 (b) Place the synchronizer ring on the gear and align the ring slots with the shifting keys.

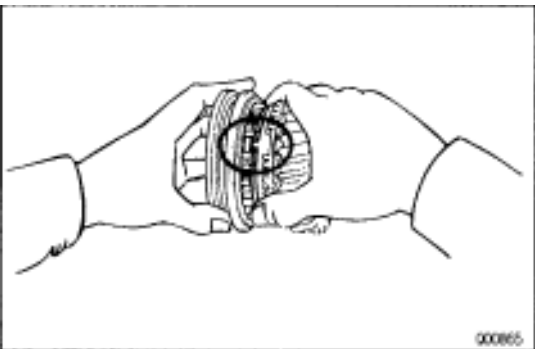

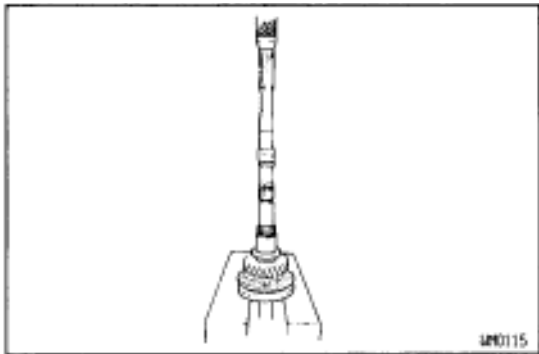

(c) Using a press, install the 3rd gear and No.2 clutch hub.

3. INSTALL SNAP RING

(a) Select a snap ring that will allow minimum axial play.

Mark	Thickness mm (in.)
C-1	1.75–1.80 (0.0689–0.0709)
D	1.80–1.85 (0.0709–0.0728)
11	1.86–1.91 (0.0732–0.0752)
12	1.92–1.97 (0.0756–0.0776)
13	1.98–2.03 (0.0780–0.0799)
14	2.04–2.09 (0.0803–0.0823)
15	2.10–2.15 (0.0827–0.0846)

(b) Using a snap ring expander, install the snap ring.

4. INSPECT 3RD GEAR THRUST CLEARANCE

Using a feeler gauge, measure the 3rd gear thrust clearance.

Standard clearance:

0.10–0.25 mm (0.0039–0.0098 in.)

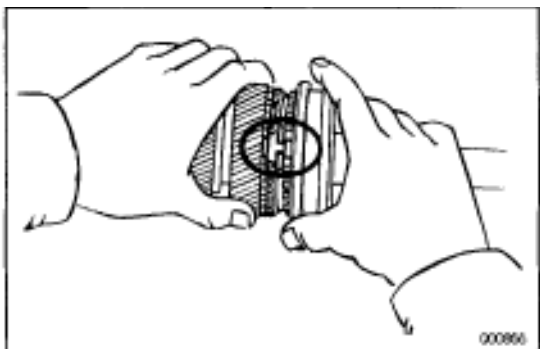

5. INSTALL 2ND GEAR AND NO.1 CLUTCH HUB

(a) Apply gear oil to the shaft and needle roller bearing.

(b) Place the synchronizer ring on the gear and align the ring slots with the shifting keys.

(c) Install the needle roller bearing in the 2nd gear.

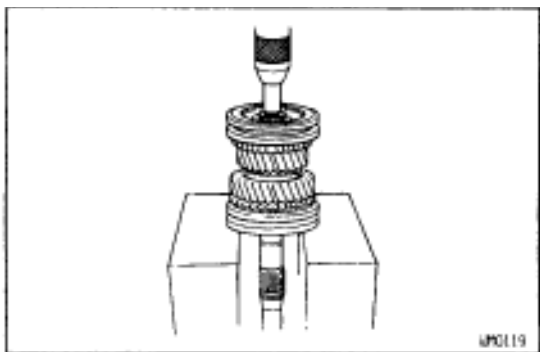

(d) Using a press, install the 2nd gear and No.1 clutch hub.

6. INSPECT 2ND GEAR THRUST CLEARANCE

Using a feeler gauge, measure the 2nd gear thrust clearance.

Standard clearance:

0.10–0.25 mm (0.0039–0.0098 in.)

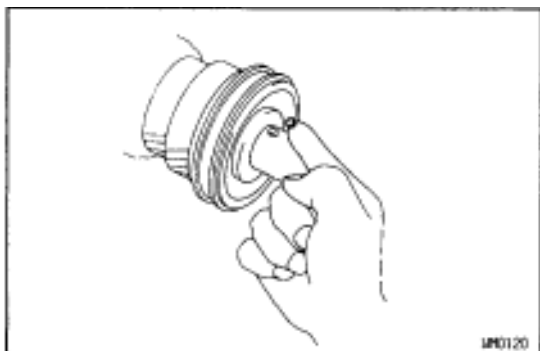

7. INSTALL LOCKING BALL AND 1ST GEAR ASSEMBLY

(a) Install the locking ball in the shaft.

(b) Apply gear oil to the bearing.

(c) Assemble the 1st gear, synchronizer ring, needle roller bearing and bearing inner race.

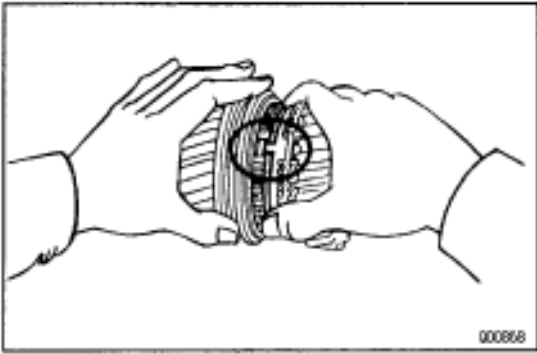

- (d) Install the assembly on the output shaft with the synchronizer ring slots aligned with the shifting keys and turn the inner race to align it with the locking ball.

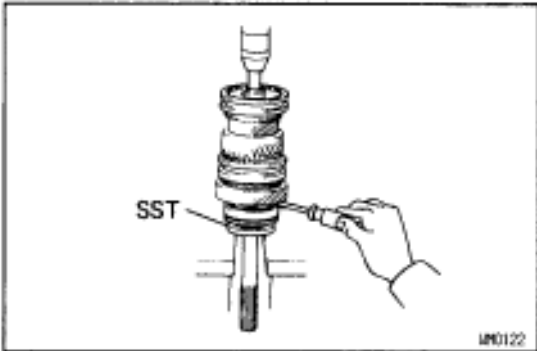

8. INSTALL OUTPUT SHAFT CENTER BEARING

Using SST and a press, install the bearing on the output shaft with the outer race snap ring groove toward the rear.

HINT: Hold the 1st gear inner race to prevent it from falling.
SST 09506-35010

9. INSPECT 1ST GEAR THRUST CLEARANCE

Using a feeler gauge, measure the 1st gear thrust clearance.

Standard clearance:

0.10–0.25 mm (0.0039–0.0098 in.)

COUNTER GEAR AND REVERSE IDLER GEAR COMPONENTS

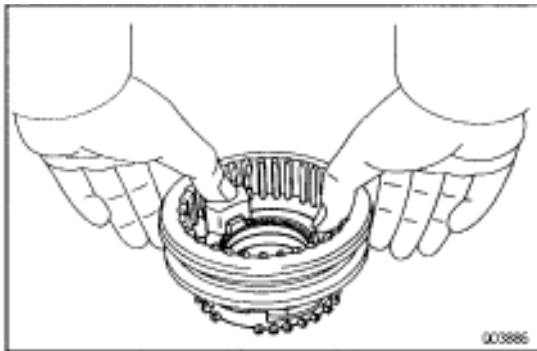
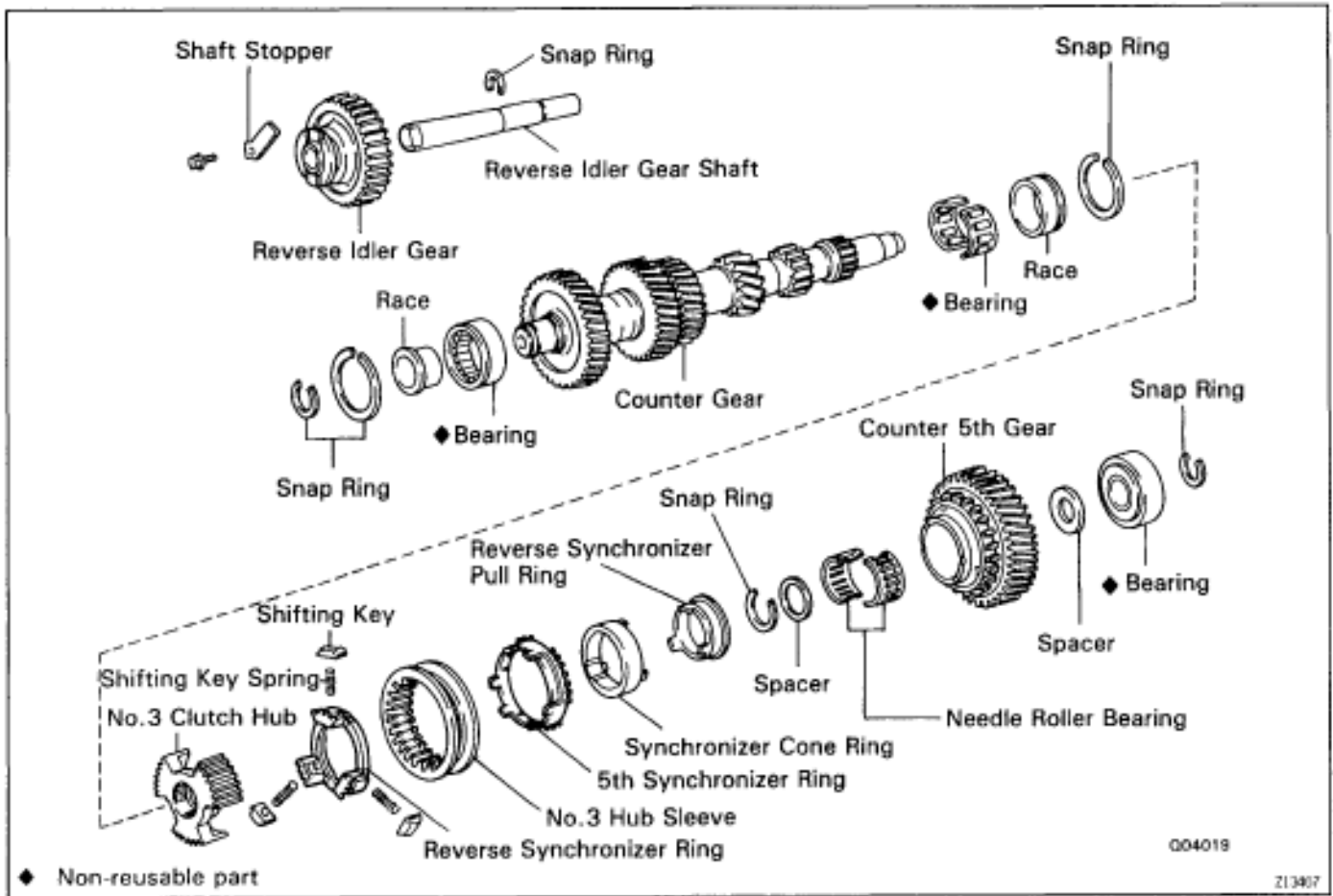

COUNTER GEAR COMPONENT PARTS DISASSEMBLY

REMOVE NO.3 HUB SLEEVE, SHIFTING KEYS AND SPRINGS FROM SYNCHRONIZER RING

- (a) Remove the synchronizer ring assembly from the No.3 hub sleeve.

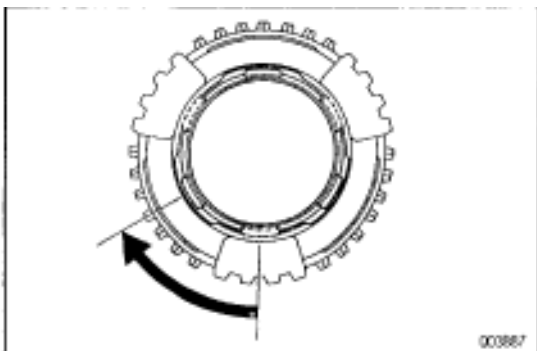

- (b) Turn the reverse synchronizer pull ring.

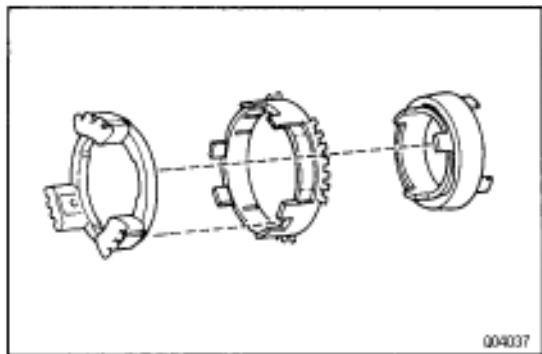

- (c) Remove the reverse synchronizer ring and 5th synchronizer ring from the synchronizer pull ring and cone ring.

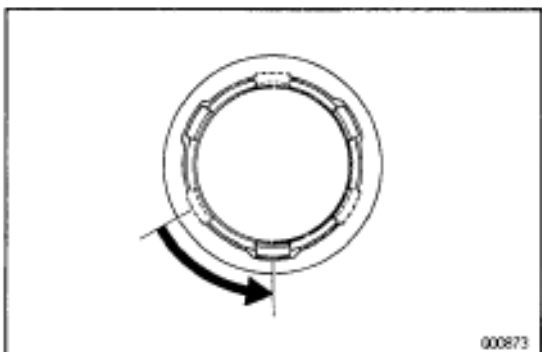

- (d) Turn the reverse synchronizer pull ring, separate the pull ring and cone ring.

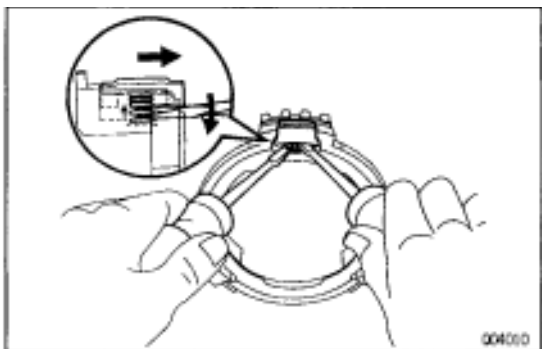

- (e) While pushing the shifting key spring to out slide with 2 screwdrivers, remove the 3 shifting keys and key springs, from the reverse synchronizer ring.

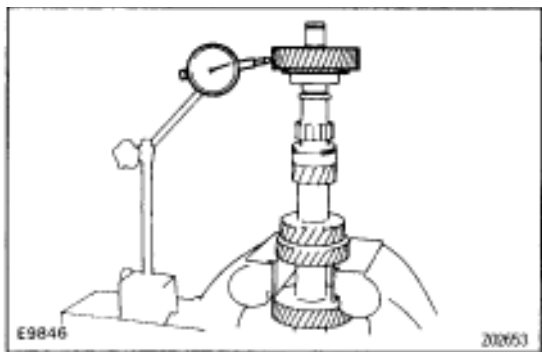

COUNTER GEAR AND REVERSE IDLER GEAR COMPONENT PARTS INSPECTION

1. INSPECT COUNTER 5 TH GEAR RADIAL CLEARANCE

- (a) Install the spacer, counter 5th gear and needle roller bearing to the counter gear.
- (b) Using a dial indicator, measure the counter 5th gear radial clearance.

Standard clearance:

0.009–0.060 mm (0.0004–0.0024 in.)

Maximum clearance:

0.150 mm (0.0059 in.)

If the clearance exceeds the maximum, replace the counter gear or needle roller bearing or counter 5th gear.

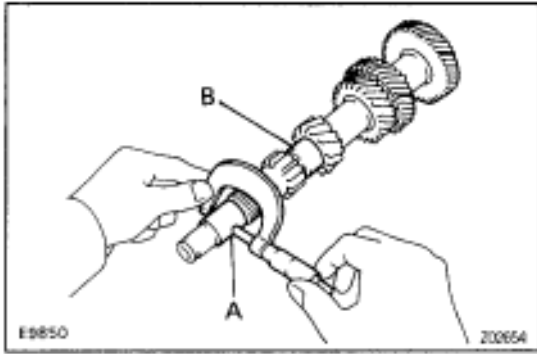

2. INSPECT COUNTER GEAR

Using a micrometer, measure the outer diameter of the counter shaft journal.

Minimum diameter:

Part A

26.975 mm (1.0620 in.)

Part B

29.950 mm (1.1791 in.)

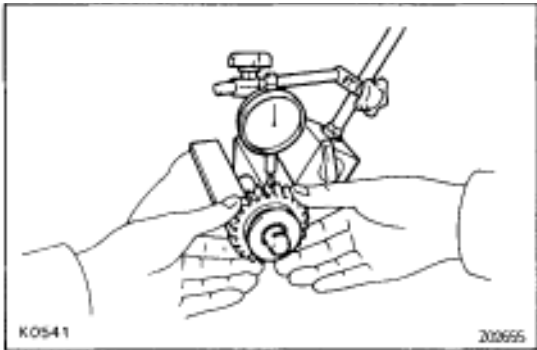

3. INSPECT REVERSE IDLER GEAR RADIAL CLEARANCE

Using a dial indicator, measure the reverse idler gear radial clearance.

Standard clearance:

0.041–0.074 mm (0.0016–0.0029 in.)

Maximum clearance:

0.194 mm (0.0076 in.)

If the clearance exceeds the maximum, replace the gear or shaft.

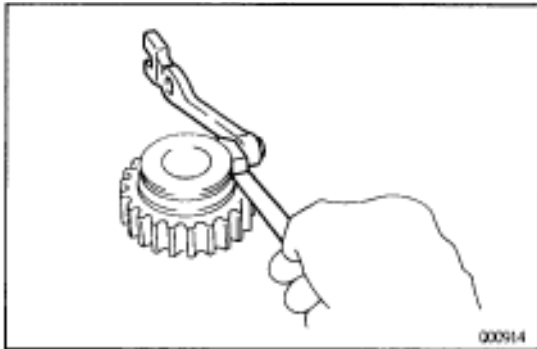

4. INSPECT CLEARANCE OF REVERSE IDLER GEAR AND SHIFT ARM SHOE

Using a feeler gauge, measure the clearance between the reverse idler gear and shift arm shoe.

Standard clearance:

0.20–0.41 mm (0.008–0.0161 in.)

Maximum clearance:

0.9 mm (0.0354 in.)

If the clearance exceeds the maximum, replace the shift arm shoe or reverse idler gear.

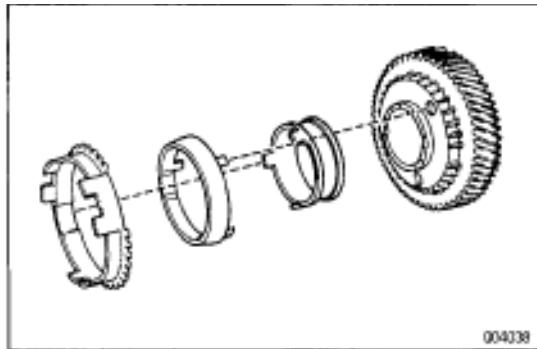

5. INSPECT 5TH GEAR SYNCHRONIZER RING

(a) Check for wear or damage.

(b) Install the synchronizer pull ring, cone ring and outer ring to the 5th gear.

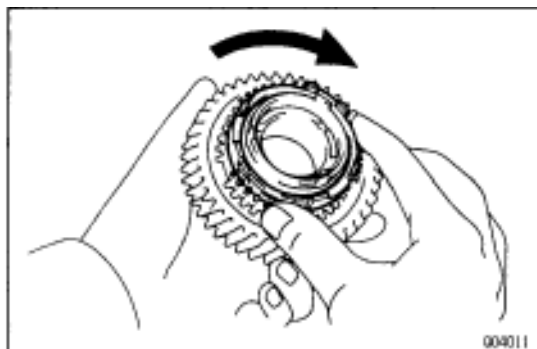

(c) Check the braking effect of the synchronizer ring.

Turn the synchronizer ring in one direction while pushing it to the gear cone. Check that the ring locks.

If it does not lock, replace the synchronizer ring.

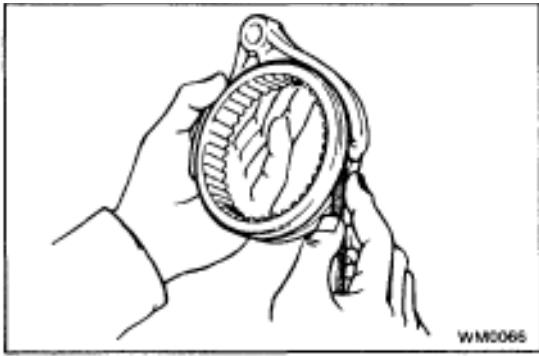

6. INSPECT CLEARANCE OF SHIFT FORKS AND HUB SLEEVES

Using a feeler gauge, measure the clearance between the hub sleeve and shift fork.

Maximum clearance:

1.0 mm (0.039 in.)

If the clearance exceeds the maximum, replace the shift fork or hub sleeve.

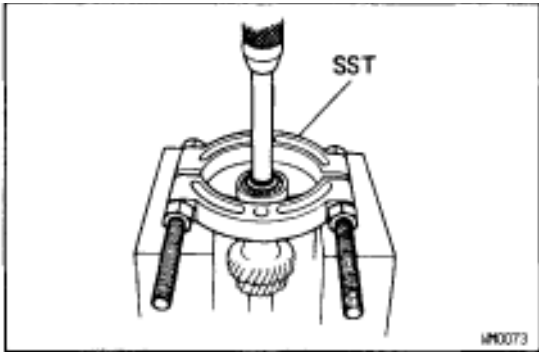

BEARING REPLACEMENT

1. IF NECESSARY, REPLACE COUNTER GEAR FRONT BEARING AND SIDE RACE

- (a) Using a snap ring expander, remove the snap ring.
- (b) Using SST and a press, press out the bearing.
SST 09950-00020
- (c) Check the side race for wear or damage.
- (d) If necessary, remove the side race.
 - Using SST and a socket wrench, remove the side race.
SST 09950-40010

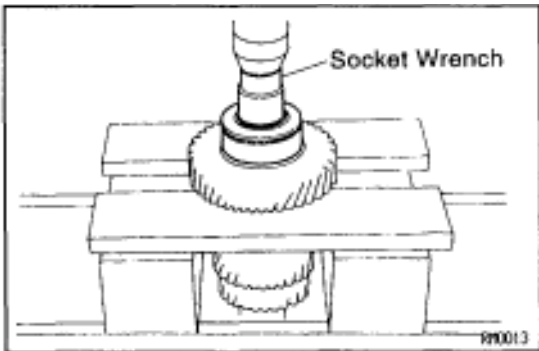
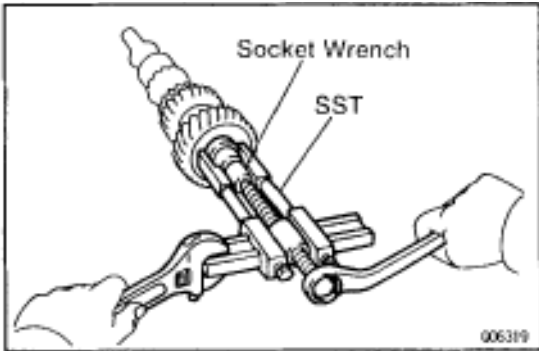

- (e) Using a socket wrench, press in a new bearing, side race and inner race.
- (f) Select a snap ring that will allow minimum axial play.

Mark	Thickness mm (in.)
A	2.05-2.10 (0.0807-0.0827)
B	2.10-2.15 (0.0827-0.0846)
C	2.15-2.20 (0.0846-0.0866)
D	2.20-2.25 (0.0866-0.0886)
E	2.25-2.30 (0.0886-0.0906)
F	2.30-2.35 (0.0906-0.0925)

- (g) Using a snap ring expander, install the snap ring.

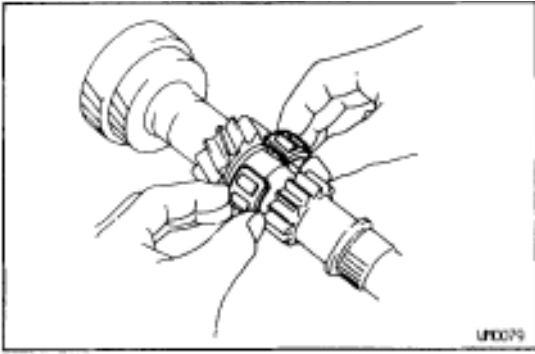

2. IF NECESSARY, REPLACE COUNTER GEAR CENTER BEARING

- (a) Remove the bearing from the counter gear.
 - (b) Install a new bearing on the counter gear.
- HINT: Engage the roller cages.

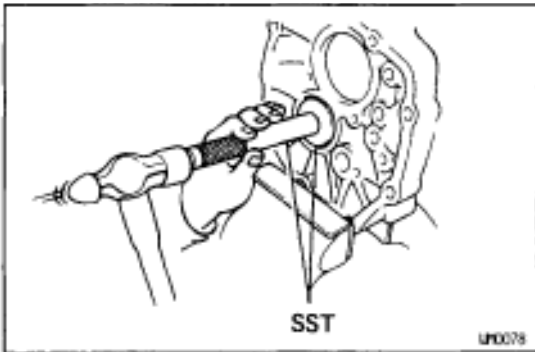

- (c) Using SST, tap out the bearing outer race.
SST 09608-35014 (09608-06020, 09608-06090)
HINT: The outer race will be installed later, as the transmission is assembled.

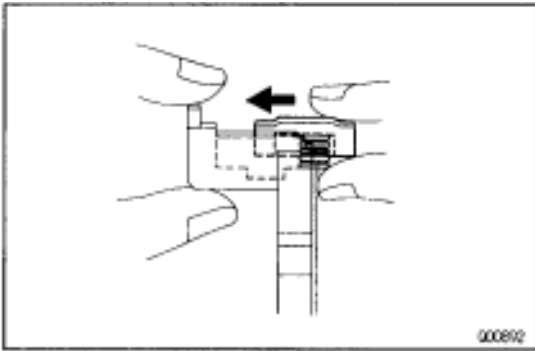

COUNTER GEAR ASSEMBLY

INSTALL SYNCHRONIZER RING ASSEMBLY TO NO.3 HUB SLEEVE

- (a) Push the synchronizer key spring, install the shifting key and key spring to the reverse synchronizer ring.

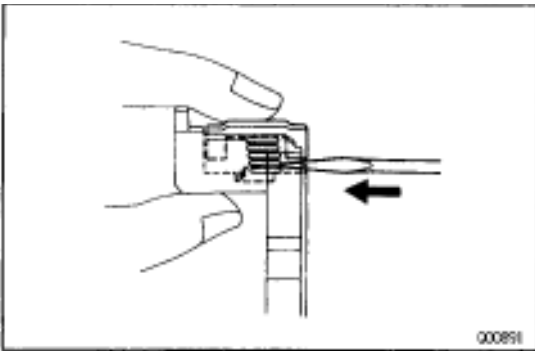

- (b) Using a screwdriver, push the 3 key springs into the synchronizer ring spring gaps.

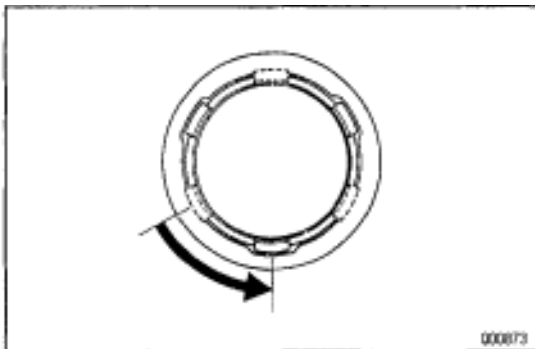

- (c) Install the synchronizer cone ring to the reverse synchronizer pull ring and turn the pull ring.

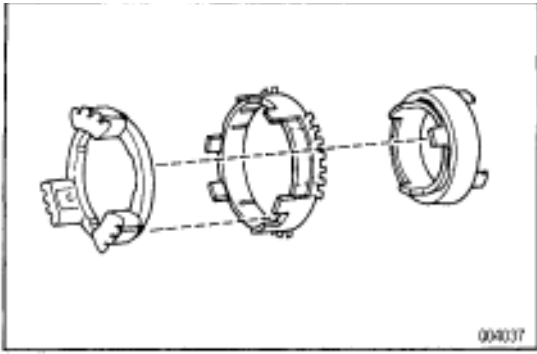

- (d) Install the 5th synchronizer ring.
- (e) Install the reverse synchronizer ring.

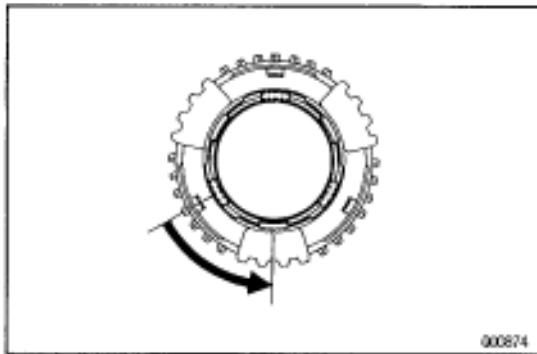

- (f) Turn the reverse synchronizer pull ring.

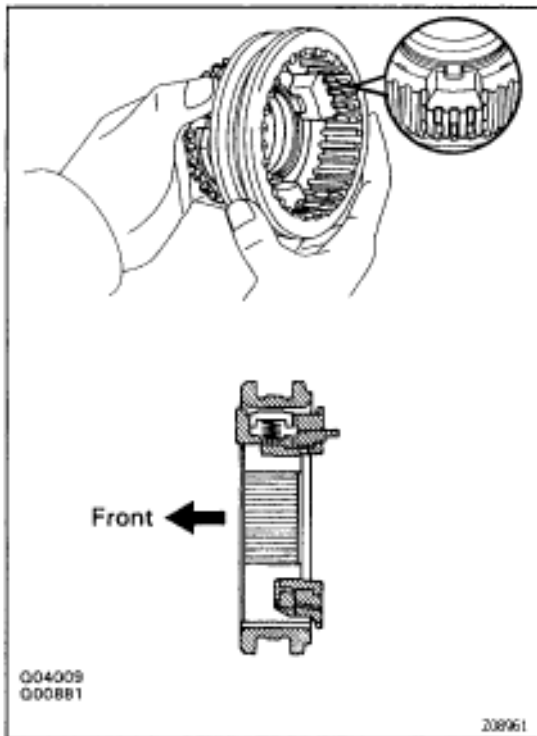

- (g) While pushing 3 shifting keys, install the synchronizer ring assembly to the No.3 hub sleeve.

FRONT BEARING RETAINER COMPONENTS

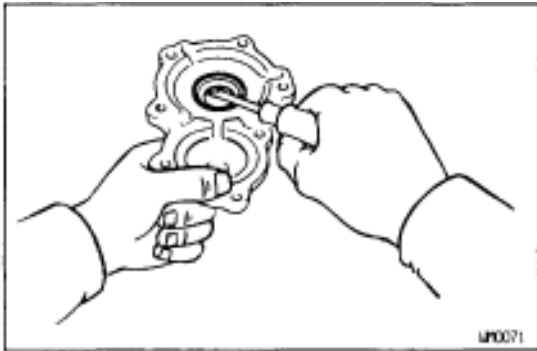
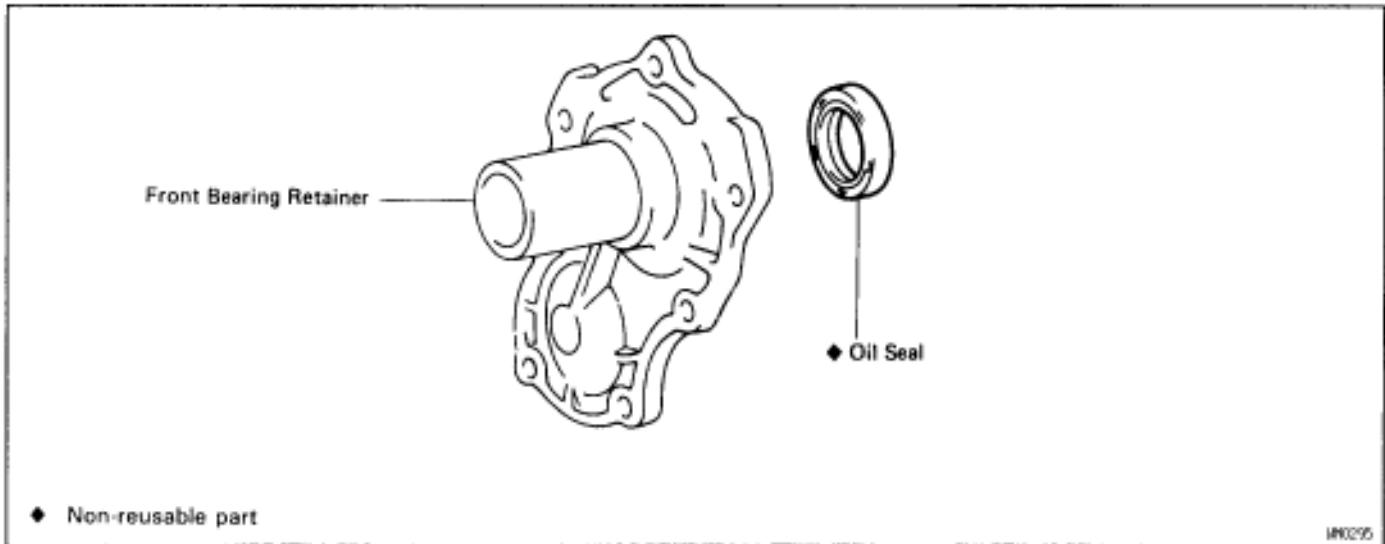

OIL SEAL REPLACEMENT

IF NECESSARY, REPLACE FRONT BEARING RETAINER OIL SEAL

- (a) Using a screwdriver, pry out the oil seal.

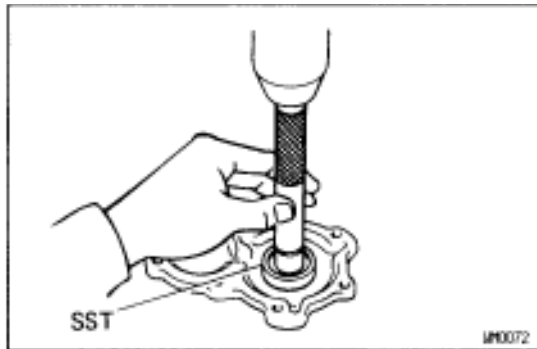

- (b) Using SST and a press, install a new oil seal.

SST 09608-20012 (09608-03020, 09608-00080)

Drive in depth:

11.4–12.0 mm (0.449–0.472 in.) from retainer end

EXTENSION HOUSING COMPONENTS

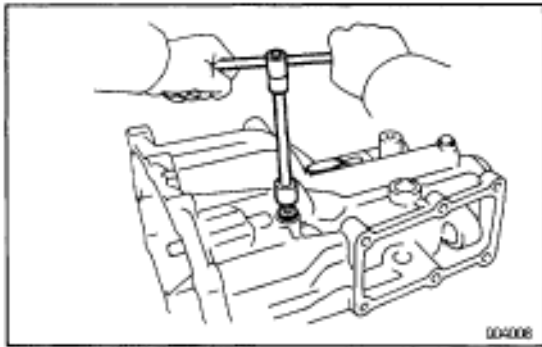
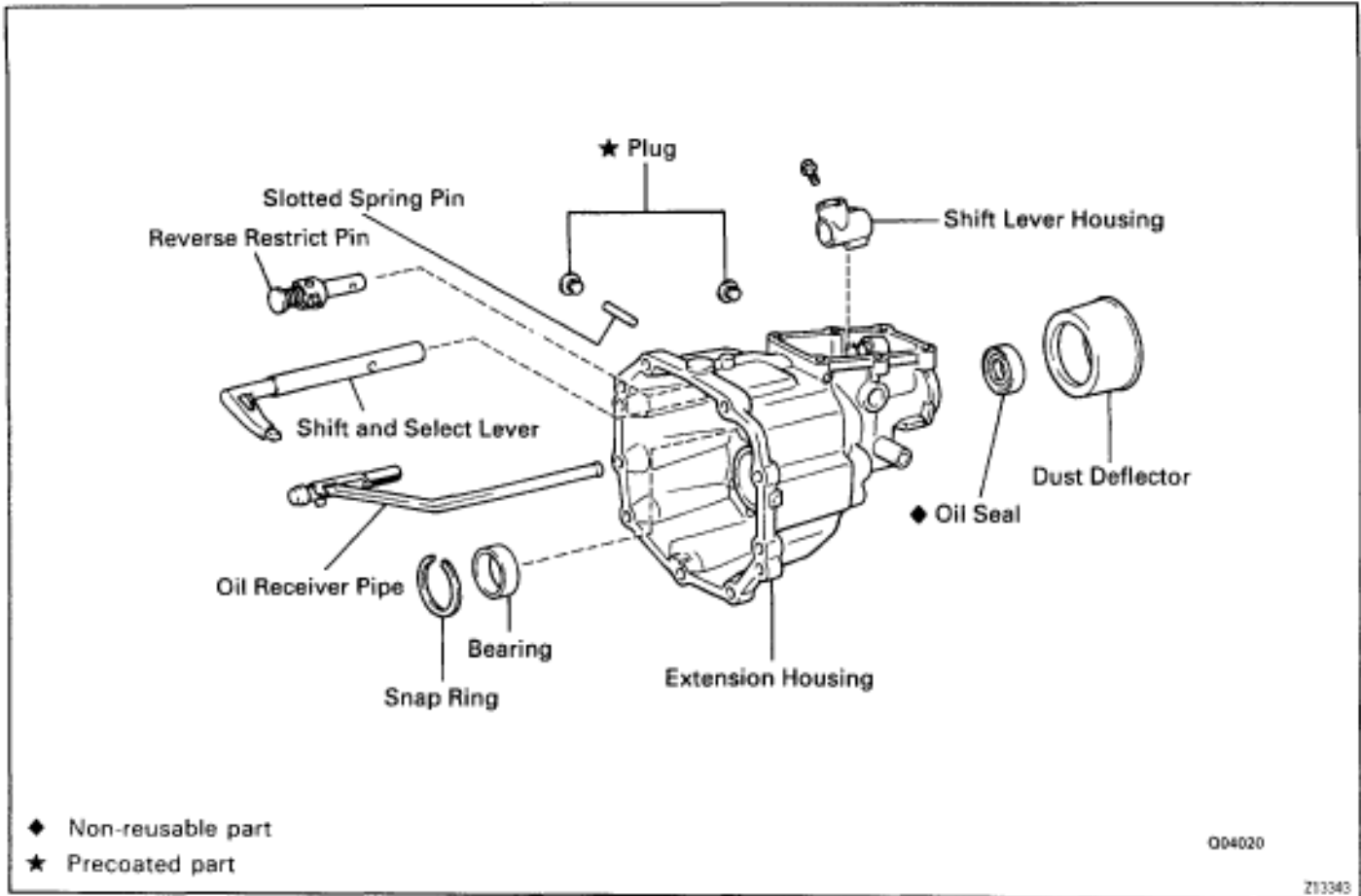

REVERSE RESTRICT PIN REPLACEMENT

1. REMOVE REVERSE RESTRICT PIN

(a) Using a hexagon wrench, remove the screw plug.

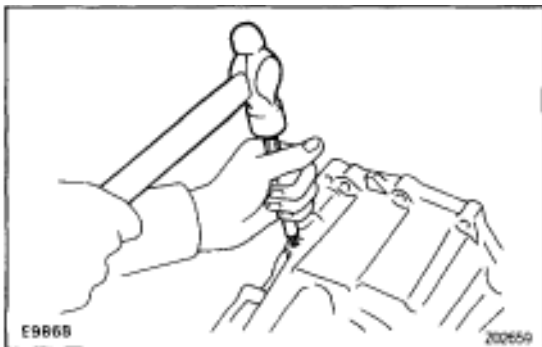

(b) Using a pin punch and hammer, drive out the slotted spring pin.

(c) Pull off the lever housing and slide out the shaft.

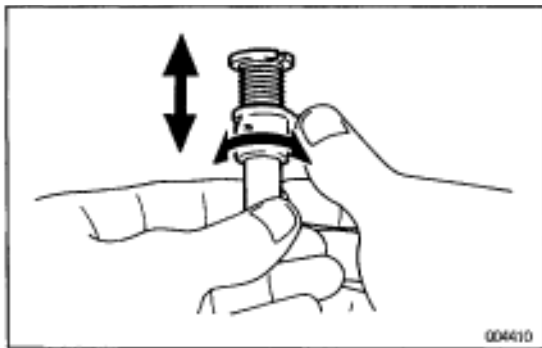

2. INSPECT REVERSE RESTRICT PIN

Turn and push the reverse restrict pin by hand. Check for smooth operation.

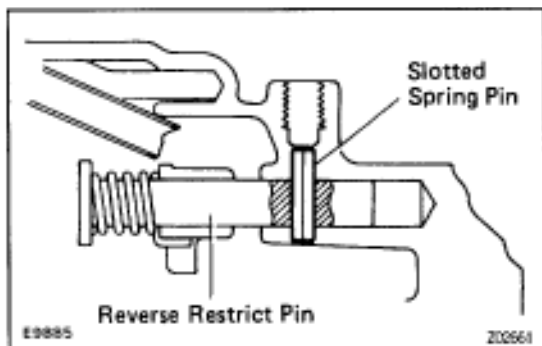

3. INSTALL REVERSE RESTRICT PIN

- (a) Install the lever housing.
- (b) Using a pin punch and hammer, drive in the slotted spring pin, as shown.

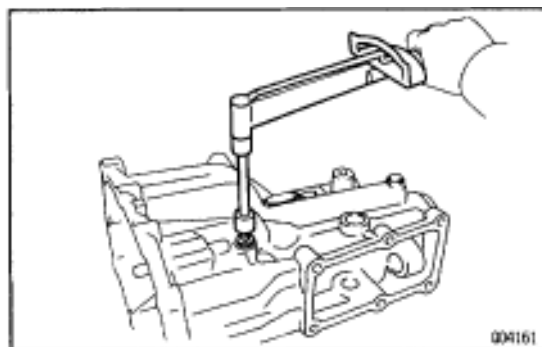

- (c) Apply sealant to the plug.

Sealant:

Part No. 08833-00080, THREE BOND 1344, LOCTITE 242 or equivalent

- (d) Install and torque the screw plug.
Torque: 25 N·m (250 kgf·cm, 18 ft·lbf)

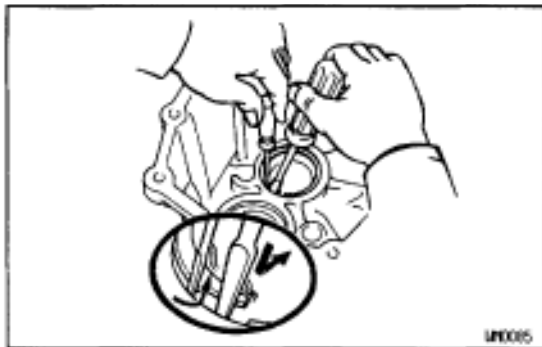

BEARING REPLACEMENT

IF NECESSARY, REPLACE REAR BEARING OUT REAR RACE

- (a) Using 2 screwdrivers, remove the snap ring.

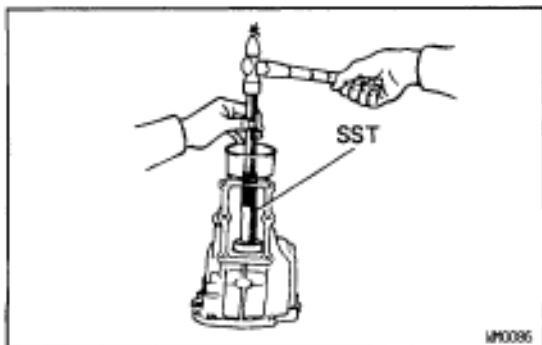

- (b) Using SST and a hammer, tap out the outer race. SST 09608-12010 (09608-00020, 09608-00050)

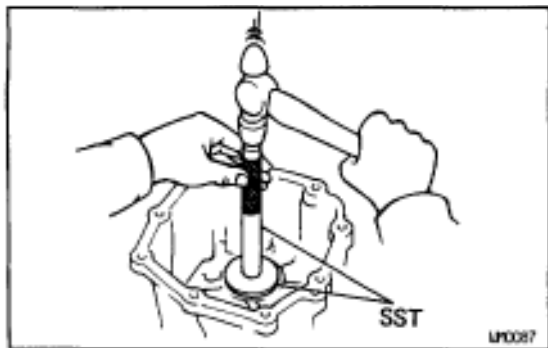

- (c) Using SST, install a new outer race. SST 09608-35014 (09608-06020, 09608-06100)

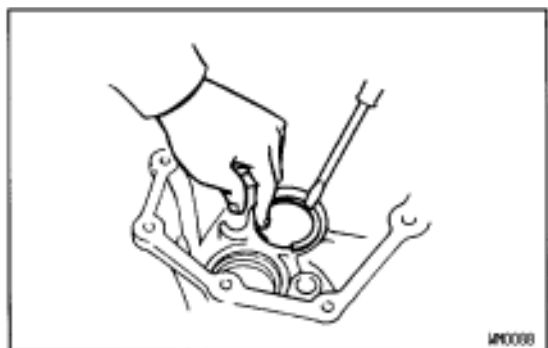

- (d) Using a screwdriver, install the snap ring.

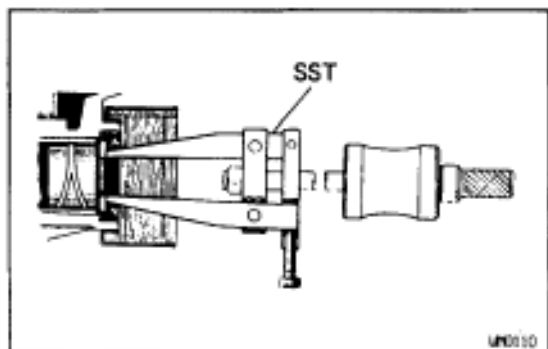

OIL SEAL REPLACEMENT

IF NECESSARY, REPLACE OIL SEAL

- (a) Using SST, remove the oil seal.
SST 09308-00010 or 09308-10010 w/ output shaft installed

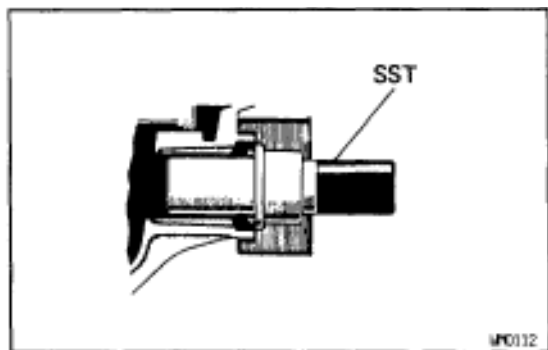

- (b) Using SST and a hammer, drive in a new oil seal. SST 09325-20010

CONTROL SHIFT LEVER RETAINER COMPONENTS

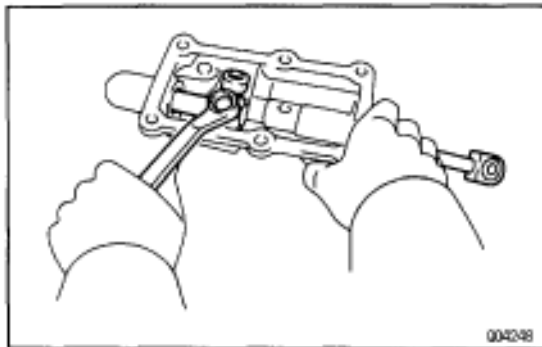
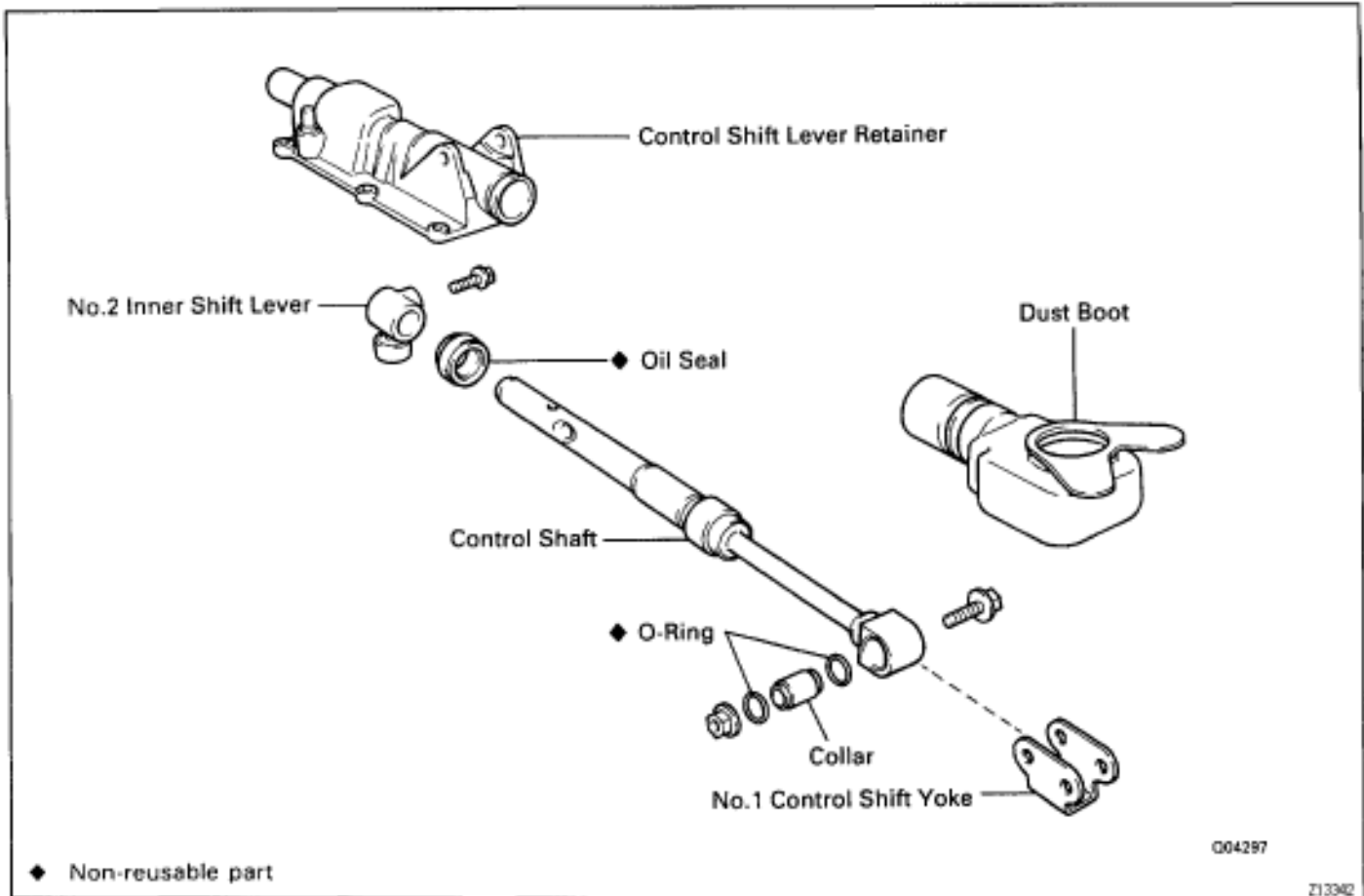

OIL SEAL REPLACEMENT

IF NECESSARY, REPLACE CONTROL SHIFT LEVER RETAINER OIL SEAL

- (a) Remove the No. 2 inner shift lever set bolt.
- (b) Remove the No. 2 inner shift lever and control shaft from the control shift lever retainer.

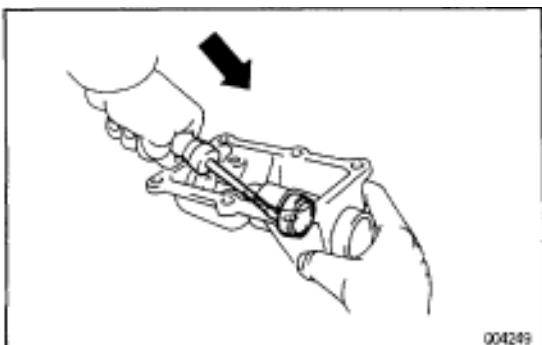

- (c) Using a screwdriver, pry out the oil seal.

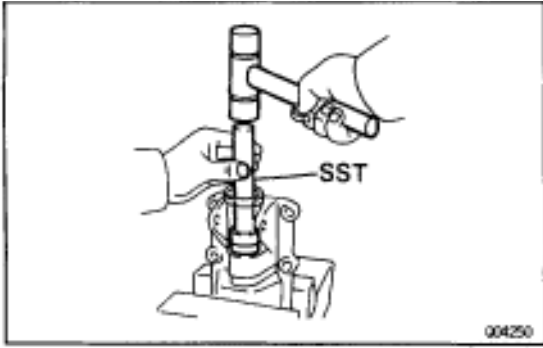

- (d) Using SST and a hammer, install a new oil seal. SST 09304-12012

Drive in depth:

55.4–56.0 mm (2.181–2.205 in.)

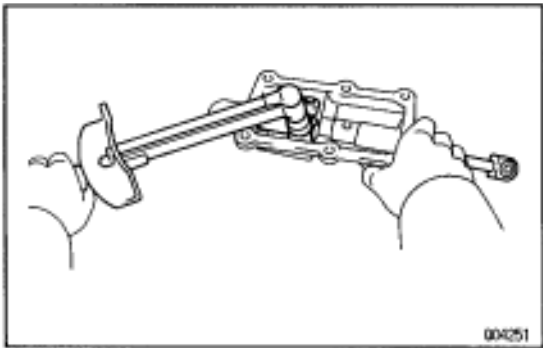

- (e) Install the control shaft and No. 2 inner shift lever to the control shift lever retainer.

- (f) Install and torque the No. 2 inner shift lever set bolt.

Torque: 39 N·m (400 kgf·cm, 29 ft·lbf)

SERVICE SPECIFICATIONS

SERVICE DATA

Output shaft 2nd gear journal diameter	
Min	42.975 mm (1.6919 in.)
Output shaft 3rd gear journal diameter	
Min	31.969 mm (1.2586 in.)
Output shaft flange thickness	
Min	5.60 mm (0.2205 in.)
Output shaft runout	
Max	0.06 mm (0.0024 in.)
1st gear inner race flange thickness	
Min	4.78 mm (0.1882 in.)
1st gear inner race outer diameter	
Min	42.975 mm (1.6919 in.)
Counter gear bearing journal diameter	
Min	29.950 mm (1.1791 in.)
Counter 5th gear journal diameter	
Min	26.975 mm (1.0620 in.)
1st, 2nd and 3rd Gear thrust clearance	
STD	0.10–0.25 mm (0.0039–0.0098 in.)
Max	0.30 mm (0.0118 in.)
Counter 5th gear thrust clearance	
STD	0.10–0.41 mm (0.0039–0.0161 in.)
Max	0.46 mm (0.0181 in.)
1st, 2nd and counter 5th gear radial clearance	
STD	0.009–0.060 mm (0.0004–0.0024 in.)
Max	0.150 mm (0.0059 in.)
3rd gear radial clearance	
STD	0.015–0.066 mm (0.0006–0.0026 in.)
Max	0.200 mm (0.0079 in.)
Reverse idler gear radial clearance	
STD	0.041–0.074 mm (0.0016–0.0029 in.)
Max	0.194 mm (0.0076 in.)
Reverse idler gear and shift arm shoe clearance	
STD	0.20–0.41 mm (0.008–0.0161 in.)
Max	0.9 mm (0.0354 in.)
Shift fork to hub sleeve clearance	
Max	1.0 mm (0.039 in.)
Synchronizer ring to 1st and 4th gear clearance	
Max	0.5 mm (0.020 in.)
Synchronizer ring to 2nd and 3rd gear clearance	
Max	0.7 mm (0.028 in.)
Input shaft snap ring thickness	
Mark 1	2.05–2.10 mm (0.0807–0.0827 in.)
Mark 2	2.10–2.15 mm (0.0827–0.0846 in.)
Mark 3	2.15–2.20 mm (0.0846–0.0866 in.)
Mark 4	2.20–2.25 mm (0.0866–0.0886 in.)
Mark 5	2.25–2.30 mm (0.0886–0.0906 in.)

	Mark 11	2.30–2.35 mm (0.0906–0.0925 in.)
	Mark 12	2.35–2.40 mm (0.0925–0.0945 in.)
Output shaft snap ring thickness		
No.2 clutch hub	Mark C–1	1.75–1.80 mm (0.0689–0.0709 in.)
No.2 clutch hub No.2	Mark D	1.80–1.85 mm (0.0709–0.0728 in.)
No.2 clutch hub	Mark 11	1.86–1.91 mm (0.0732–0.0752 in.)
No.2 clutch hub	Mark 12	1.92–1.97 mm (0.0756–0.0776 in.)
No.2 clutch hub	Mark 13	1.98–2.03 mm (0.0780–0.0799 in.)
No.2 clutch hub	Mark 14	2.04–2.09 mm (0.0803–0.0823 in.)
No.2 clutch hub	Mark 15	2.10–2.15 mm (0.0827–0.0846 in.)
Rear bearing	Mark 8	2.31–2.36 mm (0.0909–0.0929 in.)
Rear bearing	Mark 9	2.37–2.42 mm (0.0933–0.0953 in.)
Rear bearing	Mark 10	2.43–2.48 mm (0.0957–0.0976 in.)
Rear bearing	Mark 11	2.49–2.54 mm (0.0980–0.1000 in.)
Rear bearing	Mark 12	2.55–2.60 mm (0.1004–0.1024 in.)
Rear bearing	Mark 13	2.61–2.66 mm (0.1028–0.1047 in.)
Rear bearing	Mark 14	2.68–2.73 mm (0.1055–0.1075 in.)
Rear bearing	Mark 15	2.74–2.79 mm (0.1079–0.1098 in.)
Reverse gear	Mark 5	2.25–2.30 mm (0.0886–0.0906 in.)
Reverse gear	Mark 11	2.30–2.35 mm (0.0906–0.0925 in.)
Reverse gear	Mark 12	2.35–2.40 mm (0.0925–0.0945 in.)
Reverse gear	Mark 13	2.40–2.45 mm (0.0945–0.0965 in.)
Reverse gear	Mark 14	2.45–2.50 mm (0.0965–0.0984 in.)
Reverse gear	Mark 15	2.50–2.55 mm (0.0984–0.1004 in.)
Reverse gear	Mark 16	2.55–2.60 mm (0.1004–0.1024 in.)
Reverse gear	Mark 17	2.61–2.66 mm (0.1028–0.1047 in.)
Reverse gear	Mark 18	2.67–2.72 mm (0.1051–0.1071 in.)
Reverse gear	Mark 19	2.73–2.78 mm (0.1075–0.1094 in.)
Reverse gear	Mark 20	2.79–2.84 mm (0.1098–0.1118 in.)
Reverse gear	Mark 21	2.85–2.90 mm (0.1122–0.1142 in.)
Reverse gear	Mark 22	2.91–2.96 mm (0.1146–0.1165 in.)
Reverse gear	Mark 23	2.97–3.02 mm (0.1169–0.1189 in.)
Counter gear snap ring thickness		
Front bearing	Mark A	2.05–2.10 mm (0.0807–0.0827 in.)
Front bearing	Mark B	2.10–2.15 mm (0.0827–0.0846 in.)
Front bearing	Mark C	2.15–2.20 mm (0.0846–0.0866 in.)
Front bearing	Mark D	2.20–2.25 mm (0.0866–0.0886 in.)
Front bearing	Mark E	2.25–2.30 mm (0.0886–0.0906 in.)
Front bearing	Mark F	2.30–2.35 mm (0.0906–0.0925 in.)
No.3 clutch hub	Mark 2	2.06–2.11 mm (0.0811–0.0831 in.)
No.3 clutch hub	Mark 3	2.12–2.17 mm (0.0835–0.0854 in.)
No.3 clutch hub	Mark 4	2.18–2.23 mm (0.0858–0.0878 in.)
No.3 clutch hub	Mark 5	2.24–2.29 mm (0.0882–0.0902 in.)
Rear bearing	Mark 1	1.90–1.95 mm (0.0748–0.0768 in.)
Rear bearing	Mark 2	1.96–2.01 mm (0.0772–0.0791 in.)
Rear bearing	Mark 3	2.02–2.07 mm (0.0795–0.0815 in.)
Rear bearing	Mark 4	2.08–2.13 mm (0.0819–0.0839 in.)
Rear bearing	Mark 5	2.14–2.19 mm (0.0843–0.0862 in.)
Rear bearing	Mark 6	2.20–2.25 mm (0.0866–0.0886 in.)

Rear bearing	Mark 7	2.26–2.31 mm (0.0890–0.0909 in.)
Oil seal drive in depth		
Front bearing retainer (from retainer end)		11.4–12.0 mm (0.449–0.472 in.)
Control shift lever retainer		55.4–56.0 mm (2.181–2.205 in.)

TORQUE SPECIFICATIONS

Part tightened	N·m	kgf·cm	ft·lbf
Transmission x Engine			
12 mm bolt	72	730	53
10 mm bolt	37	380	27
Engine rear mounting x Transmission	25	250	18
Rear engine mounting member			
Nut	13	135	10
Bolt	25	260	19
Transmission x Starter	39	400	29
Clutch release cylinder set bolt	13	130	9
Transmission shift lever x Transmission	19	195	14
Propeller shaft x Differential	93	950	69
Propeller shaft center bearing	49	500	36
Crossmember brace set bolt	13	130	9
Heat insulator set nut	5.4	55	48 in.·lbf
Exhaust center pipe x Tail pipe	19	195	14
Exhaust front pipe x Exhaust center pipe	43	440	32
Exhaust pipe support bracket set bolt	37	380	27
Exhaust No.2 front pipe x Exhaust front pipe	43	440	32
Oxygen sensor set nut	18	180	13
Shift lever x Control shift lever arm	7.8	80	69 in.·lbf
Shift fork set bolt	20	200	14
Straight screw plug	25	250	18
Reverse idler gear shaft stopper bolt	25	250	18
Oil separator x Intermediate plate	18	185	13
Front bearing retainer set bolt	25	250	18
Extension housing x Intermediate plate	37	380	27
Restrict pin	40	410	30
Shift lever housing x Shift and select lever shaft	39	400	29
Control shift lever retainer x Extension housing	18	185	13
No.2 inner shift lever x Control shaft	39	400	29
No.1 control shift yoke x Control shaft	19	195	14
Drain and filler plugs	39	400	29
Back-up light switch	40	410	30
Control shift lever arm x Control shift lever retainer	25	250	18
Control shift lever arm x Extension housing	19	195	14
Clutch housing x Transmission case	37	380	27
Rear bearing retainer x Intermediate plate	18	185	13